

Non-Welded Grease Duct Systems Installation, Operation, and Maintenance Manual

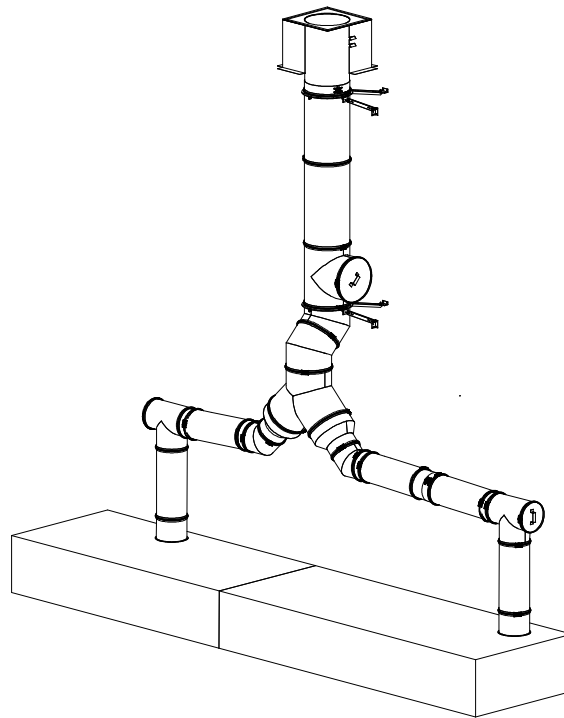

FOR YOUR SAFETY

TWO MAJOR CAUSES OF GREASE DUCT RELATED FIRES: (1) FAILURE TO MAINTAIN REQUIRED CLEARANCE (AIR SPACE) TO COMBUSTIBLE MATERIALS AND (2) FAILURE TO CLEAN GREASE LADEN DUCTS. IT IS OF UTMOST IMPORTANCE THAT THIS GREASE DUCT BE INSTALLED ONLY IN ACCORDANCE WITH THESE INSTRUCTIONS. DO NOT INSTALL GREASE DUCT WITHOUT FIRST READING THESE INSTRUCTIONS VERY CAREFULLY.

This grease duct is ETL listed to standard UL-1978 and does not have to be welded in the field.

Grease duct installed in accordance with these installation instructions will comply with national safety standards and building codes.

This booklet contains complete information on details concerning dimensions, installation and clearances to combustibles. For any additional construction information, refer to Duct Work Catalog.

TABLE OF CONTENTS

WARRANTY.....	3
LISTINGS.....	4
APPLICATION	4
MECHANICAL.....	5
Joint Sealant	5
Sealant Features	5
Table 1 – Sealant Usage Chart.....	5
Grease Duct Standard Connection.....	6
Fig.1 – Joint Assembly	6
Collar & Adjustable Duct Connections.....	7
Fig. 2 – Adjustable Duct Overlap.....	7
Collar & Adjustable Duct Vertical Installation	7
Table 2 – Minimum Overlap	7
Fig. 2a – Adjustable Duct Overlap.....	7
Fig. 2b – Collar & Adjustable Duct Installation	8
Risers – Factory & Field (Bolted & Welded) Risers.....	8
Fig. 3 – Field Installed Riser - Bolted	9
Fig. 4 – Duct Drain.....	9
Duct Drains	9
Grease Manifold Tee	9
Fig. 5 - Grease Manifold Tee Position.....	9
Access Door (Tee Cap) Assembly.....	10
Fig. 6 – Access Door Assembly	10
Fan Adapter Plate.....	11
Fig. 7 – Fan Adapter Plate	11
Prevention of Grease Accumulation in Horizontal Grease Duct.....	11
Alignment & Bracing of Grease Duct.....	11
Table 3 – Horizontal Support Spacing.....	11
Horizontal Support & Support Spacing	11
Fig. 8 – Horizontal Support Details.....	12
Wall Guide Support & Support Vertical Spacing.....	12
Table 4 – Vertical Support Spacing.....	12
Fig. 9 – Vertical Support Details.....	13
Grease Duct Assembly Examples	14
Fig. 10 - Grease Duct Installation Guide	14
Fig. 11 - Grease Duct Installation Guide	15
Fig. 12 - Grease Duct Installation Guide	16
CLEARANCES.....	17
Table 5 – Clearance – Grease Duct	17
Zero Clearances to Combustibles	18
METHODS USED TO TEST DUCT AFTER ASSEMBLY	18
Method 1 – Light Test per IMC 506.3.3.1	18
Method 2 – Smoke Test.....	18
GENERAL DUCT WEIGHT.....	18
Formula 1 – 20 Gauge Duct	18
Formula 2 – 18 Gauge Duct	18
NOTES.....	19
CLEANING & MAINTENANCE RECORD	20

WARRANTY

This duct work system is warranted to be free from defects in material and workmanship, under normal use and service, for a period of 12 months from the date of shipment. This warranty shall not apply if:

1. The equipment is not installed by a qualified installer per this installation guide, this guide should be kept with the equipment once installation is complete.
2. The equipment is not installed in accordance with federal, state and local codes and regulations.
3. The equipment is misused or neglected.
4. The equipment is not operated within its published capacity.
5. The invoice is not paid within the terms of the sales agreement.

The MANUFACTURER shall not be liable for incidental and consequential losses and damages potentially attributable to malfunctioning equipment. Should any part of the equipment prove to be defective in material or workmanship within the 12-month warranty period, upon examination by the MANUFACTURER, such parts will be repaired or replaced by the MANUFACTURER at no charge. The BUYER shall pay all labor costs incurred in connection with such repair or replacement. Equipment shall not be returned without MANUFACTURER'S prior authorization and all returned equipment shall be shipped by the BUYER, freight prepaid to a destination determined by the MANUFACTURER.

LISTINGS

This grease duct is ETL listed to standard UL-1978 when installed in accordance with these installation instructions and National Fire Protection Association Standard “NFPA 96, Standard for Ventilation Control and Fire Protection of Commercial Cooking Operations”.

APPLICATION

The listed grease duct is suitable for use in commercial cooking installations for the removal of smoke and grease laden vapors. The grease duct system includes all components for a complete exhaust system from the hood to the exhaust fan inlet.

Grease duct installations require provisions for cleaning the interior of the duct. NFPA 96 cleanout requirements are as follows:

1. A cleanout must be provided at each change of direction except where the entire length of duct can be inspected and cleaned from either the hood or the discharge end.
2. On horizontal duct runs, at least one (1) 20” diameter opening must be provided. Where the opening is smaller than 20” diameter, openings large enough to permit cleaning must be provided at intervals of no more than 12’.
3. Openings must be at the side or the top, whichever is more accessible. When the opening is on the side of the duct, the lower edge of the opening must be at least 1 ½” above the bottom of the duct. For the listed grease duct, this is accomplished by the use of the grease manifold tee and cleanout cap.
4. On vertical duct runs where personnel entry is possible, access must be from the top of the riser. Where entry is not possible, access must be provided at each floor.

NOTE: ACCESS REQUIREMENTS ARE SUBJECT TO CHANGE IN ACCORDANCE WITH LOCAL CODE. LOCAL AUTHORITIES SHOULD BE CONSULTED FOR EXACT REQUIREMENTS. GREASE DUCT MAY BE CONNECTED ONLY TO HOODS IN A SINGLE FIRE ZONE ON ONE FLOOR. DO NOT CONNECT GREASE DUCTS TO ANY OTHER PART OF THE BUILDING VENTILATION OR EXHAUST SYSTEM.

When grease duct is installed in accordance with these installation instructions and the joints are sealed properly with the recommended sealant, the system will contain a grease fire within the duct. A grease fire can burn at extremely high temperatures. This system should be dismantled and inspected after any exposure to a grease fire. Any section that is distorted or discolored should be replaced. All joints in the system should be examined. Because the sealant expands to assure a positive seal in the case of a fire, any sealant that has been exposed to high temperature must be replaced. This will ensure that the system maintains its integrity against fire conditions in the future. The manufacturer of this grease duct can not be responsible for grease duct systems that are not properly maintained or have been subjected to one or more grease fires.

Grease duct systems size and capacity information may be obtained from the “ASHRAE Handbook – Fundamentals” or from the “Air Pollution Engineering Manual” of the “US Environmental Protection Agency”. Refer to the grease duct systems catalog for descriptions and dimensional data of parts.

MECHANICAL

Joint Sealant

The joint sealant used to seal all joint assemblies is a 3M product. 3M Fire Barrier 2000 + Silicone Sealant is a ready-to-use, gun-grade, one-component silicone elastomer that cures upon exposure to atmospheric humidity to form a flexible seal. 3M Fire Barrier 2000 + Silicone Sealant, when installed properly, will control the spread of fire before, during and after exposure to open flames. It will stop the spread of noxious gas, smoke and water and maintain the integrity of fire rated assemblies and construction. **NO SEALANT SUBSTITUTES MAY BE USED.**

Sealant Features

1. Superior adhesion.
2. Capable of withstanding 2000 F + temperatures.
3. Class 25 sealant, per ASTM 920.
4. Re-enterable/repairable.
5. Provides up to 4-hours fire-rating.
6. Cures upon exposure to atmospheric humidity.
7. Working time 30 minutes.
8. Cure time 14 to 21 days.
9. Applied with a standard caulk gun.

Table 1 – Sealant Usage Chart

3M FIRE BARRIER 2000 PLUS USAGE			
DIAMETER	DUCT PERIMETER FT	AVERAGE FEET PER TUBE	NUMBER OF JOINTS PER TUBE
8"	2.16	30	7
10"	2.68	30	6
12"	3.21	30	5
14"	3.73	30	4
16"	4.25	30	3.5
18"	4.78	30	3
20"	5.30	30	3
24"	6.35	30	2.5

Grease Duct Standard Connection

1. Apply a continuous bead of proper sealant around the flange to be joined. The bead should be $\frac{1}{4}$ " thick and continuous.
2. Join the two flanged ends of the duct section together.
3. Fill the "V" clamp with the proper sealant. The bead should be inside the "V".
4. Install the "V" clamp around the duct sections. Both duct flanges should be inside the "V".
5. Secure the "V" clamp around the duct by tightening the $\frac{1}{4}$ -20 hardware to 85 inch lbs.
6. See **Fig. 1** below for details.
7. Remove any excess sealant from the inside of the duct surface.

IMPORTANT: THE HARDWARE USED TO ASSEMBLE THIS DUCTWORK IS SPECIFICALLY DESIGNED FOR THIS APPLICATION. NO SUBSTITUTE HARDWARE IS ALLOWED. ALL REPLACEMENT HARDWARE MUST BE PURCHASED FROM THE DUCTWORK FACTORY.

Fig.1 – Joint Assembly

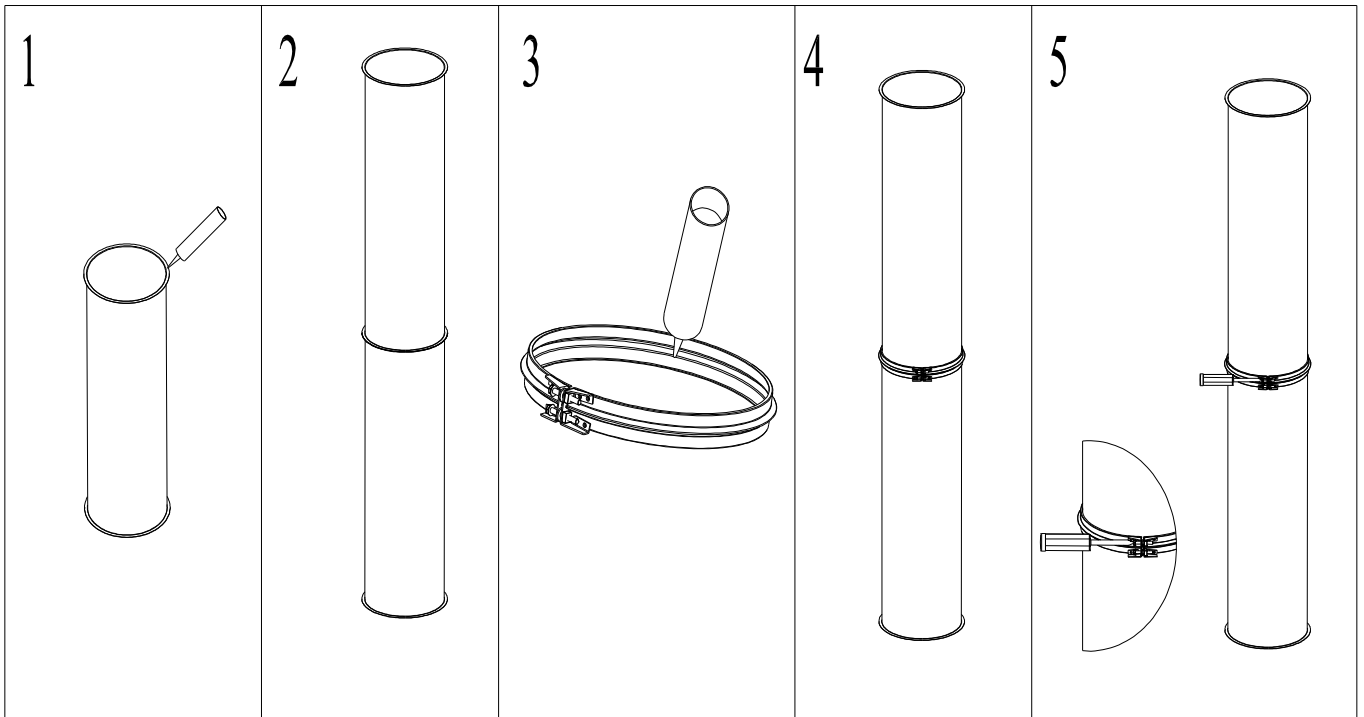

Collar & Adjustable Duct Connections

The collar and the adjustable length duct have two major functions: (1) Make up odd lengths of duct as needed in short runs as in termination of the duct at the exhaust fan. (2) Serve as an expansion joint for thermal expansion in larger runs of duct.

When used in systems of any orientation, it can perform both functions simultaneously. The adjustable duct section is overlapped to allow grease to drain back to the hood in both vertical and horizontal installations See **Fig.10**. The adjustable duct is flanged at one end only. The collar is constructed of the same material as the duct, and is also designed with a 1/2" flange that is connected to the standard duct section using the joint assembly method listed above See **Fig.1**. Collars are also sealed using high temperature silicone that compresses around the adjustable duct when the collar hardware is tightened. The collar is designed to securely hold the adjustable duct, while allowing for thermal expansion.

Fig. 2 – Adjustable Duct Overlap

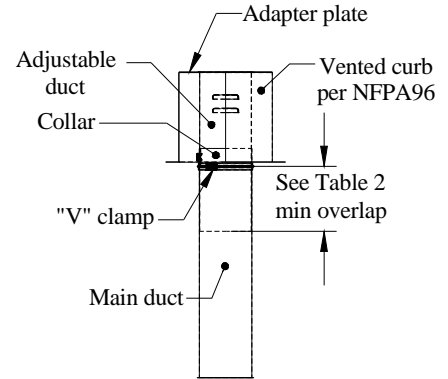

Collar & Adjustable Duct Vertical Installation

When the adjustable length duct and collar are installed in the vertical position between two fixed points, such as the beginning support and the ending support, it should be installed just below the higher support. To ensure proper axial alignment, wall guide support assemblies must be installed below the duct joint immediately below the adjustable duct. This combination of parts will force the sliding inner and outer parts of the adjustable duct to overcome collar friction allowing movement along the axis of the duct and thus relieving expansion stresses which would otherwise develop between the fixed points of the heated vertical duct.

1. Slide the adjustable collar over the adjustable duct. Flanges should be opposite.
2. Slide the adjustable duct into the standard duct to the point that the collar flange and the standard duct flange meet.
3. The adjustable collar and standard duct are joined and sealed using the method listed above in **Fig.1**.
4. Slide the adjustable duct into the standard duct to the desired length. The minimum overlap dimension depends on the duct diameter. See **Table 2**. for proper overlap dimensions.
5. The collar is sealed to duct using high temperature silicone.
6. Once the desired overlap has been met, tighten the 1/4-20 hardware on the "V" clamp and the outside of the adjustable collar to 85 inch lbs.
7. Inspect the connection for gaps in silicone.

Table 2 – Minimum Overlap

DIAMETER	MIN OVERLAP FOR ADJUSTABLE DUCT
8"	4"
10"	5"
12"	6"
14"	6"
16"	6"
18"	6"
20"	6"
24"	6"

Fig. 2a – Adjustable Duct Overlap

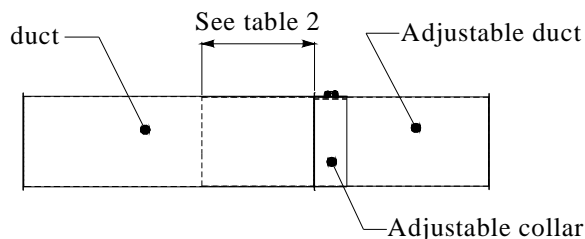
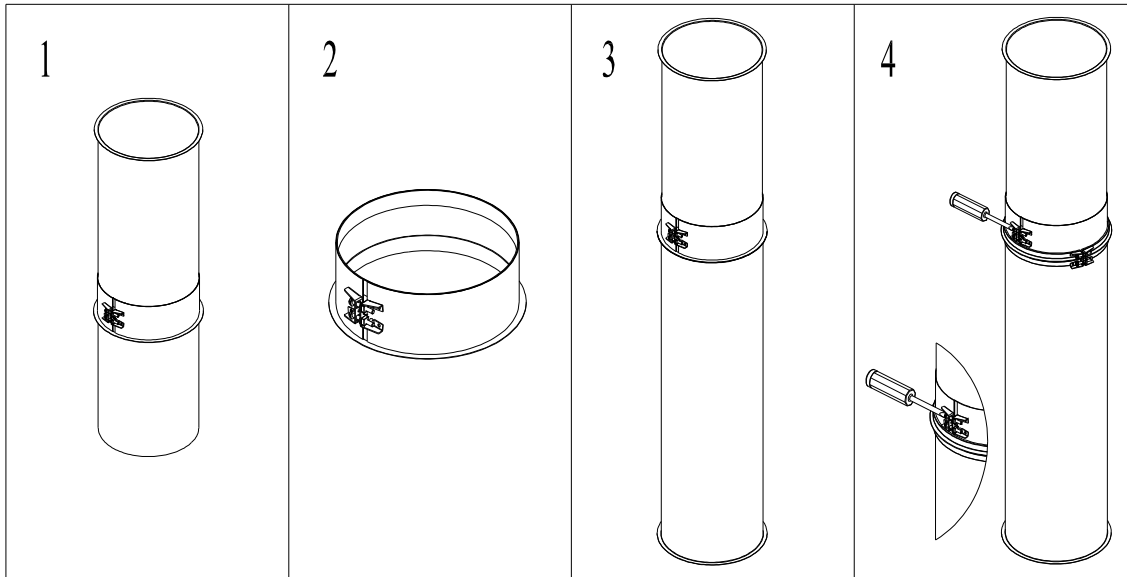

Fig. 2b – Collar & Adjustable Duct Installation



Risers – Factory & Field (Bolted & Welded) Risers

There are two options for the riser (connection to hood plenum); Factory welded and field welded or bolted.

Dimensional data identifying the size and location of the riser must be provided for factory installation. The riser is fully welded to the hood plenum.

When field installed, the riser is shipped loose allowing the installer at the jobsite to decide on the final location of the riser. Field installed risers help when the final location is not known or adjustments may have to be made due to duct misalignments. Field installed risers may be welded or bolted in place.

1. Bolted risers come with two rings that are used for the connection to the hood plenum, one is connected to the riser and one will be loose.
2. Locate the desired position of the riser on the top of the hood. Use the riser as a guide when marking the top of the hood. Make sure that the hole location is inside the plenum area before cutting.
3. Since the riser is going to be bolted on, a bolt hole circle is required. Use the loose ring as a guide.
4. Use the high temperature silicone provided to seal above and below the cut hole, there should be no gaps in the silicone either around the cut hole or the bolt hole circle.
5. Center the riser over the cut hole and push down into the silicone. The silicone should be visibly coming through the bolt hole circle on the riser ring.
6. Align the loose riser ring over the hole on the inside of the plenum and push into the silicone. Align with the riser ring above the hood and bolt the two rings together using ¼-20 hardware.
7. Excess silicone should be removed, and the connection should be inspected for gaps and loose hardware.
8. When joining standard duct to the riser use the method shown in **Fig. 1 – JOINT ASSEMBLY**.

Fig. 3 – Field Installed Riser - Bolted

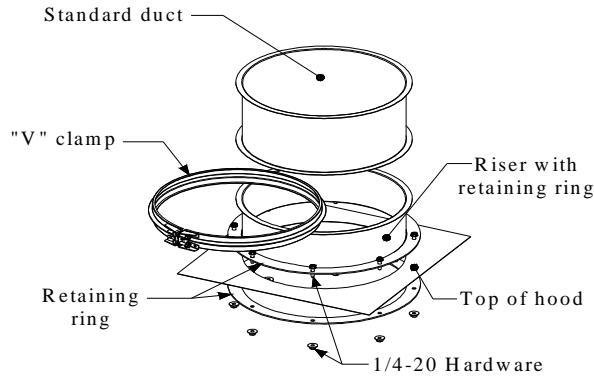

Duct Drains

Drains are used to provide a point at which low points in the duct system can be drained. Condensation and low lying water left over from duct cleaning can be drained easily with the installation of the ball valve drain. Drains are designed to aid in duct cleaning and can be used to drain grease into an approved grease collection reservoir. Drains are offered in two different sizes; 1 and 1-1/2 inch. The 1 inch drain is used on 8" through 14" diameter duct and the 1-1/2 inch drain is used on the 16" through 24" diameter duct. See **Fig. 4.** for details.

Grease Manifold Tee

The grease manifold tee is used to provide access for cleanout to comply with NFPA 96 requirements. It is equipped with an internal blank that acts as a grease dam and gasket. The access port is then closed with a cleanout cap or tee cap. The location of the access port in the tee is dependent on the orientation of the tee in the final installation. Access port location is coded as Position 1, 2, 3, 4 see **Fig. 5.** Access ports are never located where grease can build up and fall out once the cleanout cap is removed.

Fig. 4 – Duct Drain

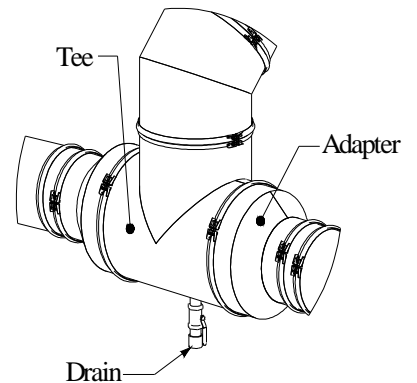
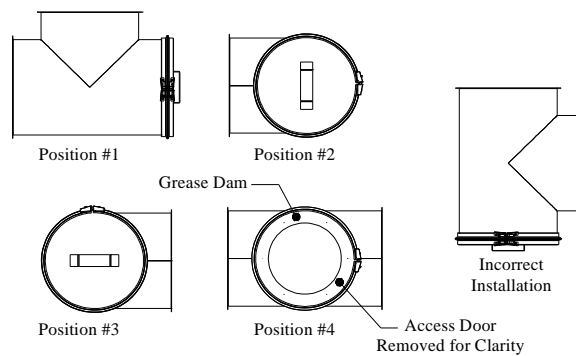

Fig. 5 - Grease Manifold Tee Position



Access Door (Tee Cap) Assembly

Access doors (tee caps) are available 8" to 24". They work in conjunction with the manifold tee as previously shown in **Fig. 5**. The tee joint connection is shown in **Fig. 1 – JOINT ASSEMBLY**; however, the installation of the access door is slightly different so read the following instructions very carefully. Consult NFPA 96, Chapter 7, Section 7.3.1 "Openings shall be provided at the sides or at the top of the duct, whichever is more accessible, and at change of directions".

1. Select the location and the position of the access door.
2. All tee joints will be connected as shown in **Fig. 1 – JOINT ASSEMBLY** except for the access door.
3. Apply the proper sealant to the flange of the tee that will be used for access to the duct system.
4. Apply a ¼" continuous bead around the flange.
5. Center the inside blank (grease dam) over the opening of the tee and apply pressure. Pushing the inside blank down onto the tee flange that has been siliconed.
6. Apply enough pressure to create a positive bond between the tee flange and the inside blank. Remove excess sealant after making parts concentric (centered).
7. Sealant will begin to cure upon exposure to atmospheric humidity. It will form a flexible seal.
8. Once the sealant is dry attach the access door using a "V" clamp. Ensure flanges are in the "V" before tightening ¼-20 hardware to 85 inch lbs.

Fig. 6 – Access Door Assembly

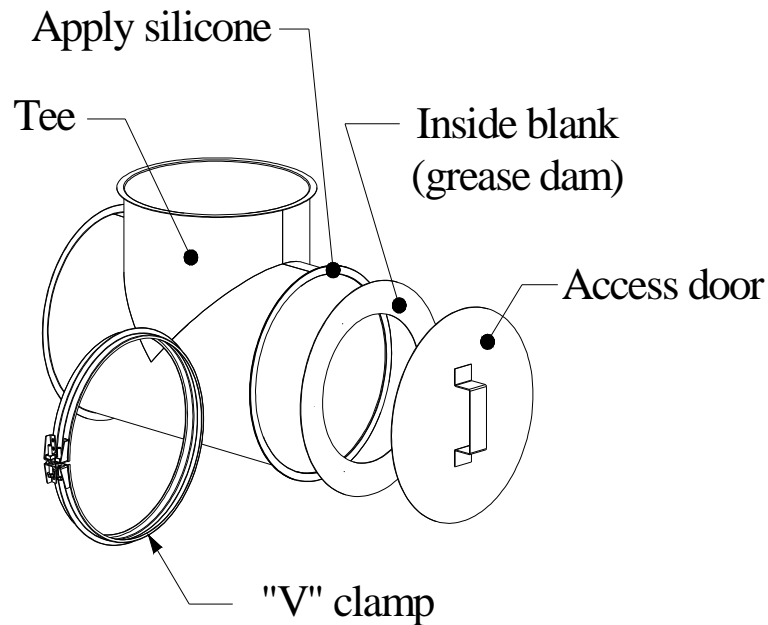

Fan Adapter Plate

The fan adapter plate (Transition Plate) is designed to connect to a roof curb. The duct section is welded to the underside of the adapter plate. The adapter plate is formed to provide a slope to allow grease deposits to flow back towards the duct. When connected, see **Fig. 7**, the plate mounts on top of the fan curb, which supports the fan housing. The plate may be positioned off center within the curb provided that the minimum distance to combustibles is maintained. In the event that the plate is positioned off center, trim off excess plate material to allow for fan placement. Secure the plate to the curb using a minimum of three fasteners per side. A suitably sized fastener provided by others is used. The fan adapter plate can be used to maintain distance to combustibles and also for vertical support.

Fig. 7 – Fan Adapter Plate

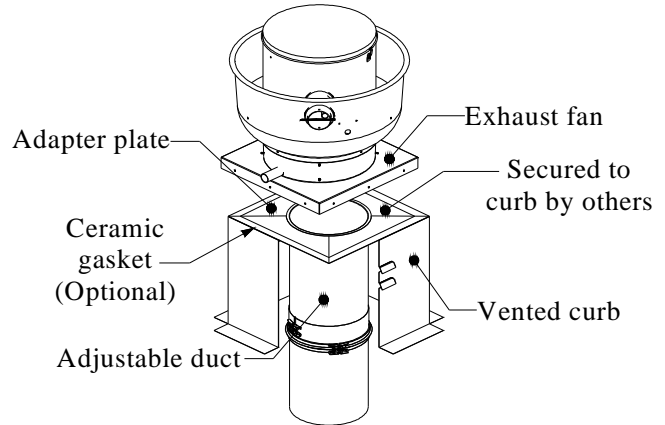

Prevention of Grease Accumulation in Horizontal Grease Duct

Duct systems serving Type 1 hoods shall be constructed and installed so that grease cannot collect in any portion of the duct system. The duct system shall slope not less than $\frac{1}{4}$ " per linear foot towards the hood or toward an approved grease collection reservoir. Where horizontal ducts exceed 75 feet in length, the slope shall not be less than $\frac{1}{2}$ " per linear foot. Offset collars have been designed to meet the above specification. The collar is used in conjunction with other accessories such as tee's and elbows to maintain the above listed slope in horizontal duct runs.

Alignment & Bracing of Grease Duct

Grease duct has the characteristics of a continuous stainless steel pipe and it will expand and contract along its entire length with changes in its temperature. For this reason, conventional methods of attaching guides and braces to the outer wall of the grease duct cannot be used. Correctly installed support rings, saddles and wall guide assemblies will serve to keep the duct aligned, provide for adequate resistance to lateral loads and allow the free axial expansion and contraction movement. A simplified rule for duct expansion is that the axial growth will be approximately 1 inch per 100 feet of pipe length for each 100 degrees Fahrenheit the exhaust vapor temperature is above the surrounding air temperature.

Horizontal Support & Support Spacing

Horizontal duct runs are supported using either 2 X 2 X $\frac{1}{8}$ " angle or Unistrut, horizontal support spacing is shown in **Table 3**. When cutting the angle or Unistrut to length there must be a minimum of 2" on either side of the duct or duct wrap. It's important that the $\frac{3}{8}$ " threaded rod suspending the angle or Unistrut does not rub against the duct or duct wrap. Once the angle has been cut to length it is suspended using $\frac{3}{8}$ " threaded rod (minimum). Appropriate sized holes are drilled/punched in either end of the angle. The $\frac{3}{8}$ " threaded rod is secured to the angle or Unistrut using appropriate sized hardware, washers are used on the top and bottom before installing nuts, double nuts are used to make sure bottom nuts do not come loose, see **Fig. 8**.

Table 3 – Horizontal Support Spacing

DIAMETER	HORIZONTAL SUPPORT SPACING (FEET)
8"	10'
10"	10'
12"	10'
14"	10'
16"	10'
18"	10'
20"	10'
24"	10'

Fig. 8 – Horizontal Support Details

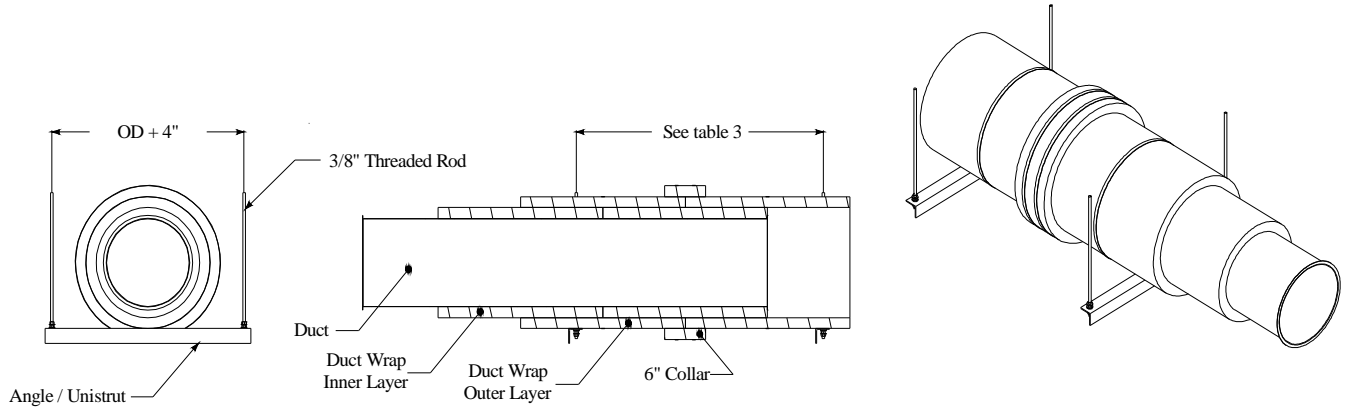

Wall Guide Support & Support Vertical Spacing

The wall guide is to be attached to Non-Combustible and Combustible surfaces. The wall guide is constructed of 12 gauge steel and is comprised of a full ring, brackets, angle struts, wall support plates and hardware for assembly (Includes mounting hardware to secure supports to gypsum walls constructed using 25 gauge steel studs), see Fig. 9. The ring, which is split in two halves for ease of assembly, is constructed of 12 gauge steel. With the addition of a spacer between the two halves, the diameter is 1/8" larger than the outside diameter of the duct. This is to allow for thermal expansion.

The wall support should be installed at the joint of the duct and below the "V" clamp so the "V" clamp moves away from the support ring. The wall guide assembly is designed for 2 to 18 inches clearance from duct to non-combustible / combustible walls. The side struts may be placed either up or down as is convenient. This assembly is intended to resist lateral or side loads only and is not for carrying the weight of the vertical grease duct. The horizontal struts allow for attachment to the wall after the grease duct has been positioned. The angle of attachment may vary as needed for the duct to wall clearance. Wall supports shall be used at the proper spacing shown in Table 4 for vertical duct support, with appropriate expansion joints to allow for thermal expansion and wall guides for lateral stability.

Table 4 – Vertical Support Spacing

DIAMETER	VERTICAL SUPPORT SPACING (FEET)
8"	10'
10"	10'
12"	10'
14"	10'
16"	10'
18"	10'
20"	10'
24"	10'

Fig. 9 – Vertical Support Details

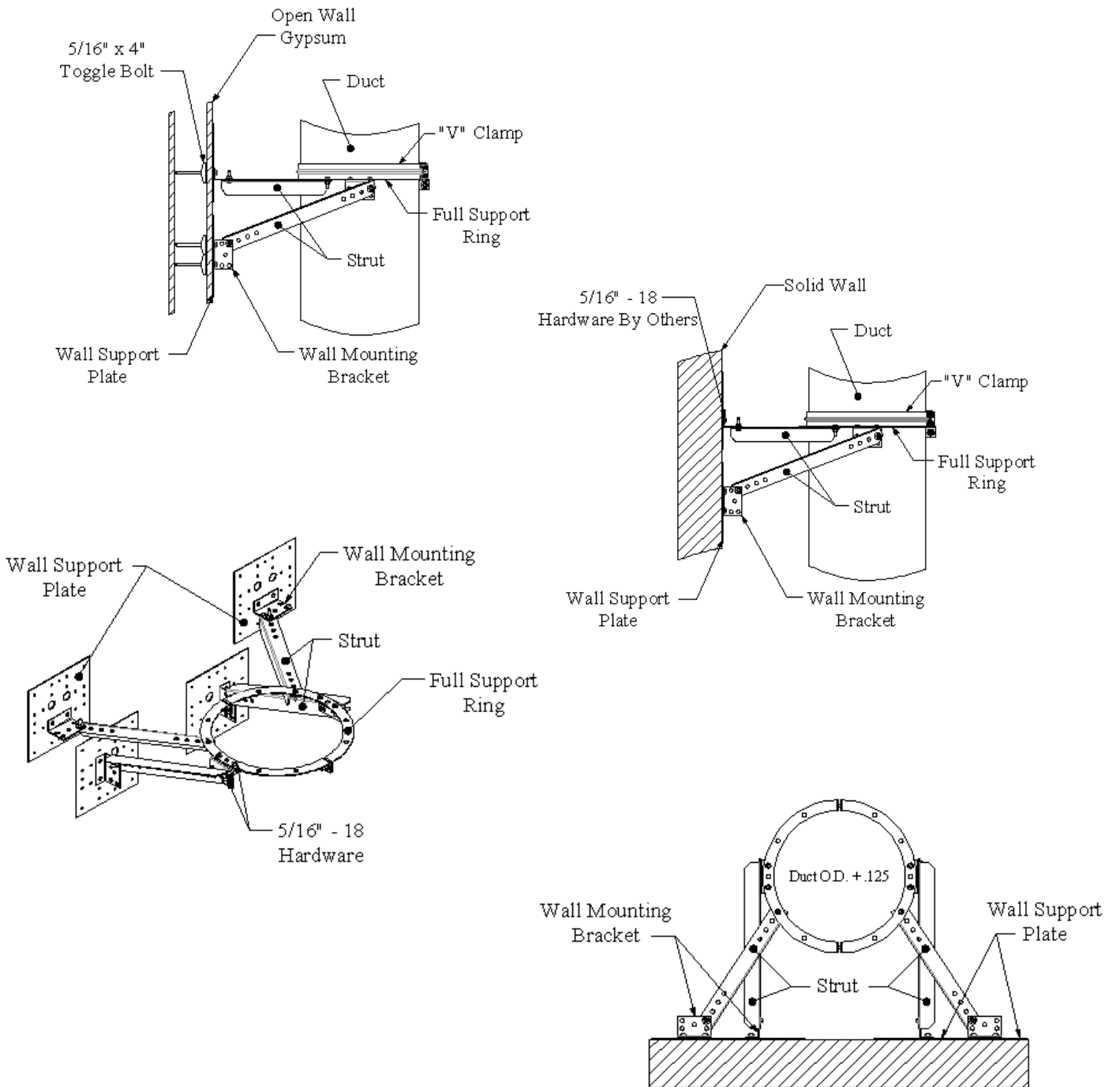

Grease Duct Assembly Examples

Fig. 10 - Grease Duct Installation Guide

Grease Duct Installation:

The illustration shown provides useful information on the installation of grease duct systems. Each installation is specific to the application and the job site. When duct systems are installed outside, welded seams must be painted with corrosion resistant high temperature paint. If you encounter a situation not covered by this illustration, refer to the guide or consult the factory. Remember, if the distance to a combustible surface is less than 18 INCHES you will need to wrap the duct in a listed duct wrap to get "ZERO CLEARANCE TO COMBUSTIBLES".

**IMPORTANT INFORMATION
PLEASE READ BEFORE INSTALLING**

This duct is designed to be installed in application where the duct system is a minimum of 18" to combustible surfaces, duct installations that cannot maintain 18" minimum clearance to a combustible surface must be insulated using a clearance reducing, listed grease duct insulation, see details in this guide.

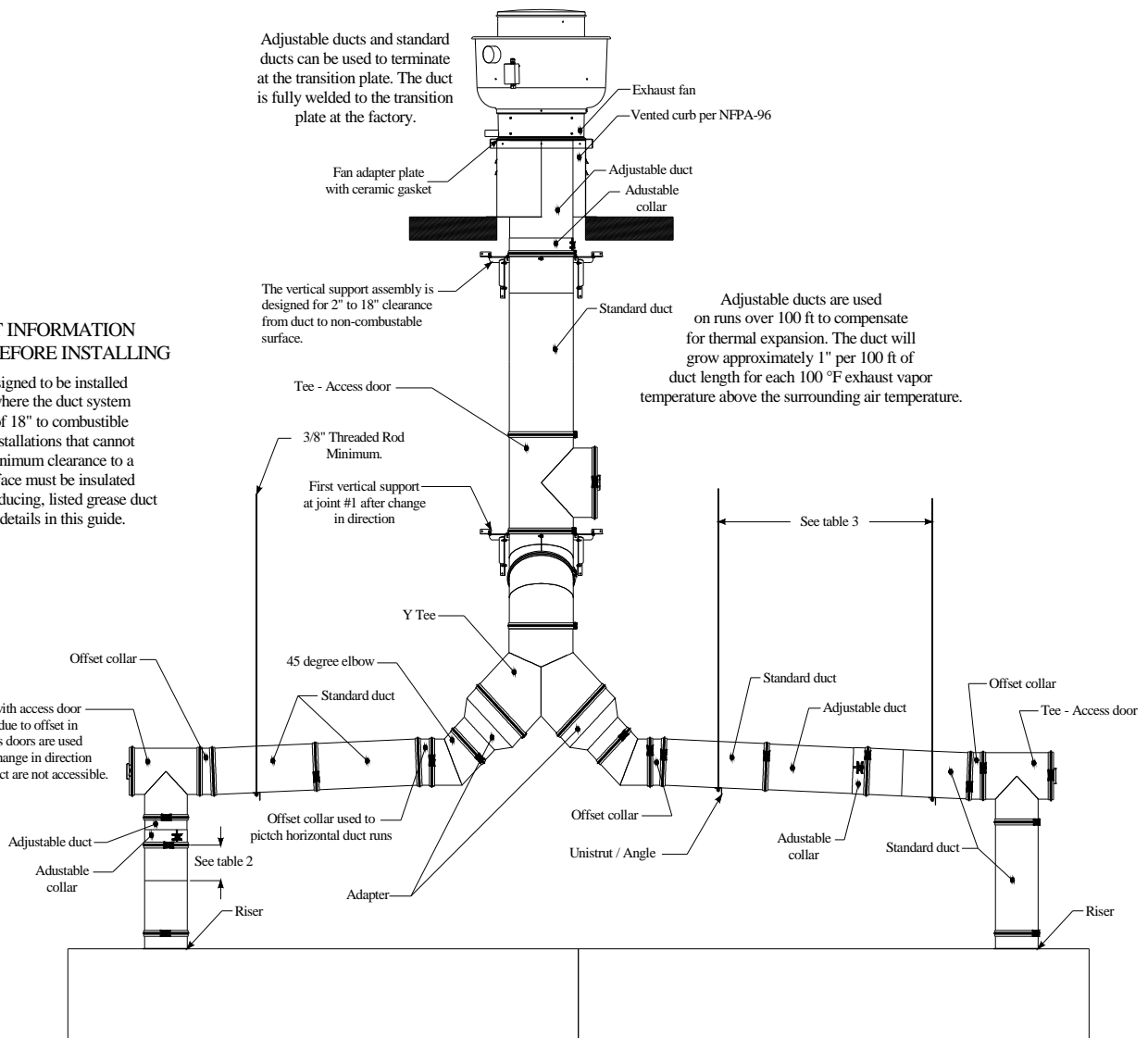
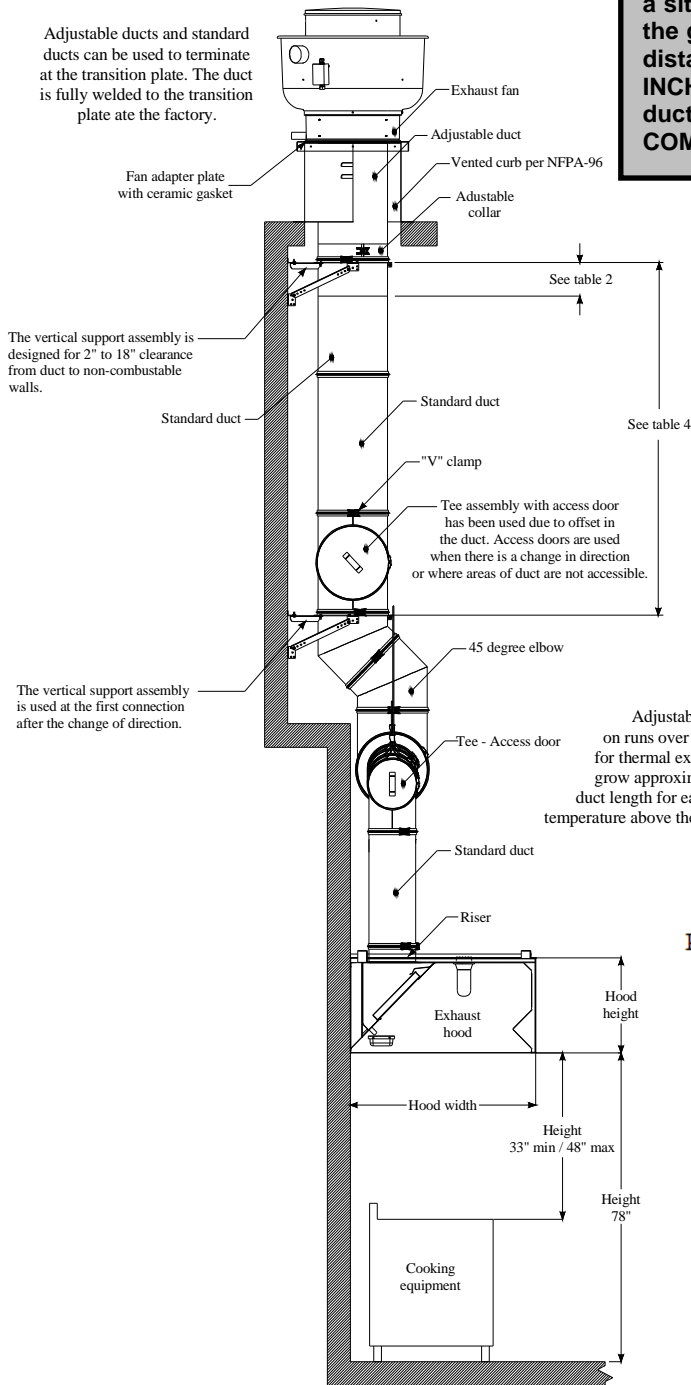

Fig. 11 - Grease Duct Installation Guide

Grease Duct Installation:

The illustration shown provides useful information on the installation of grease duct systems. Each installation is specific to the application and the job site. When duct systems are installed outside, welded seams must be painted with corrosion resistant high temperature paint. If you encounter a situation not covered by this illustration, refer to the guide or consult the factory. Remember, if the distance to a combustible surface is less than 18 INCHES you will need to wrap the duct in a listed duct wrap to get "ZERO CLEARANCE TO COMBUSTIBLES".



Adjustable ducts are used on runs over 100 ft to compensate for thermal expansion. The duct will grow approximately 1" per 100 ft of duct length for each 100 °F exhaust vapor temperature above the surrounding air temperature.

**IMPORTANT INFORMATION
PLEASE READ BEFORE INSTALLING**

This duct is designed to be installed in application where the duct system is a minimum of 18" to combustible surfaces, duct installations that cannot maintain 18" minimum clearance to a combustible surface must be insulated using a clearance reducing, listed grease duct insulation, see details in this guide.

Fig. 12 - Grease Duct Installation Guide

Grease Duct Installation:

The illustration shown provides useful information on the installation of grease duct systems. Each installation is specific to the application and the job site. When duct systems are installed outside, welded seams must be painted with corrosion resistant high temperature paint. If you encounter a situation not covered by this illustration, refer to the guide or consult the factory. Remember, if the distance to a combustible surface is less than 18 INCHES you will need to wrap the duct in a listed duct wrap to get "ZERO CLEARANCE TO COMBUSTIBLES".

Adjustable ducts and standard ducts can be used to terminate at the transition plate. The duct is fully welded to the transition plate at the factory.

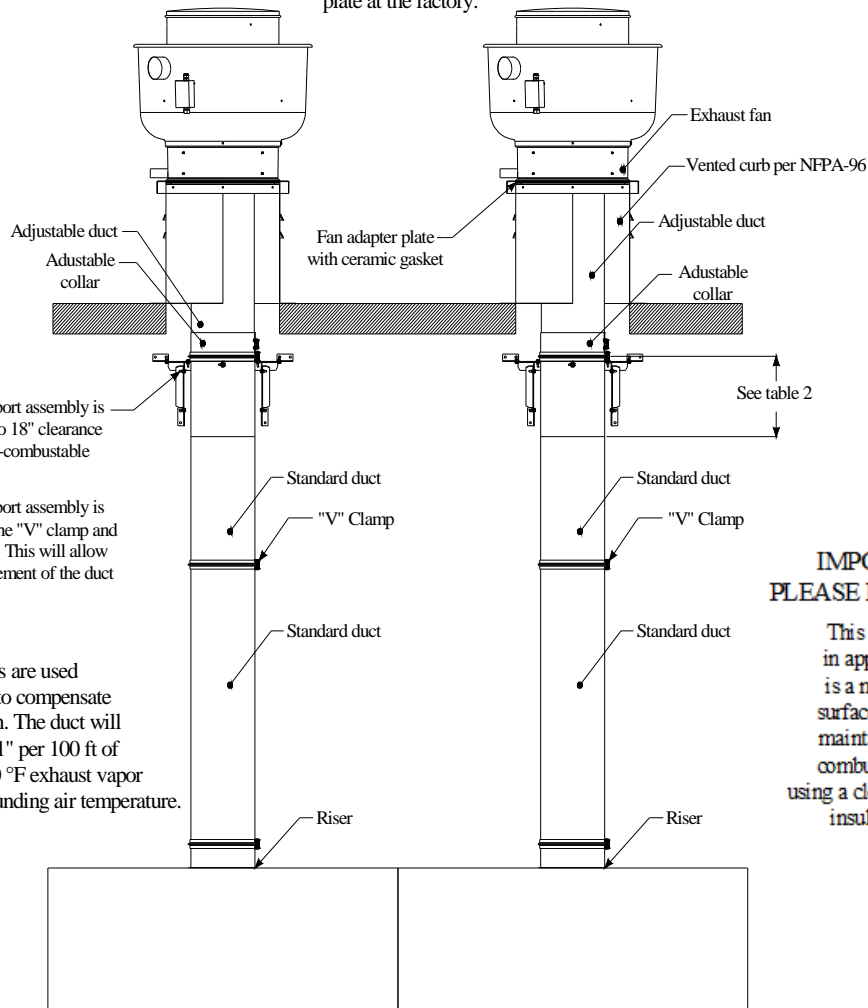

The vertical support assembly is designed for 2" to 18" clearance from duct to non-combustible walls.

The vertical support assembly is mounted under the "V" clamp and adjustable collar. This will allow the vertical movement of the duct system.

Adjustable ducts are used on runs over 100 ft to compensate for thermal expansion. The duct will grow approximately 1" per 100 ft of duct length for each 100 °F exhaust vapor temperature above the surrounding air temperature.

**IMPORTANT INFORMATION
PLEASE READ BEFORE INSTALLING**

This duct is designed to be installed in application where the duct system is a minimum of 18" to combustible surfaces, duct installations that cannot maintain 18" minimum clearance to a combustible surface must be insulated using a clearance reducing, listed grease duct insulation, see details in this guide.

CLEARANCES

This grease duct is primarily intended for use in non-combustible surroundings, when installed in a room where enclosure is not required. Grease duct may be located at clearance to combustibles in accordance with **Table 5**. Grease duct may be located in a corner formed by two combustible walls provided the minimum clearance is maintained.

In all buildings more than one story in height and in buildings where the roof-ceiling assembly is required to have a fire resistance rating, the duct must be enclosed in a continuous enclosure from the lowest fire-rated ceiling or floor above the hood, through any concealed spaces, to or through the roof to maintain the integrity of the fire separations required by the applicable building code provisions. If the building is less than 4 stories in height, the enclosure shall have a fire resistance rating of not less than 1 hour. If the building is 4 stories or more in height, the enclosure shall have a fire resistance rating of not less than 2 hours. The clearance between the outside of the duct and the inside of the rated enclosure must be a minimum of 6 inches or required by code.

Combustible roofs or roof-ceiling assemblies may be penetrated using the vertical support assembly when distance to combustible surfaces is maintained.

Table 5 – Clearance – Grease Duct

DIAMETER	CLEARANCE TO COMBUSTIBLES	CLEARANCE TO LIMITED COMBUSTIBLES	CLEARANCE TO NON COMBUSTIBLES
8"	18"	3"	0"
10"	18"	3"	0"
12"	18"	3"	0"
14"	18"	3"	0"
16"	18"	3"	0"
18"	18"	3"	0"
20"	18"	3"	0"
24"	18"	3"	0"

The above figures represent air space, in inches, to surrounding
 NOTE: See NFPA 96, 2004 EDITION, Chapter 3, Definition of Combustible, Limited Combustible and Non-Combustible.

Zero Clearances to Combustibles

This duct is to be used in non-combustible surroundings. Where the duct does not require an enclosure, it must have a minimum clearance to adjacent combustible walls as shown above in **Table 5 – CLEARANCES**. In cases where the ducting extends through any story of a building above the location at the connected appliances, it must be enclosed in the upper stories with walls having a fire resistance rating of not less than one hour for buildings of two or three stories in height. If the building is four stories or more in height, the enclosure wall shall have a fire resistance rating of not less than two hours.

METHODS USED TO TEST DUCT AFTER ASSEMBLY

Prior to the concealment of any portion of a grease duct system, a leakage test shall be performed in the presence of the code official. Duct shall be considered to be concealed where installed in shafts or covered by coatings or wraps that prevent the ductwork from being visually inspected on all sides. A light test or approved equivalent test method (smoke test) shall be performed to determine that all joints are liquid tight. The smoke test is used for longer duct runs while the light test is used for short duct runs, both methods are approved for use.

Method 1 – Light Test per IMC 506.3.3.1

A light test shall be performed by passing a lamp having a power rating of not less than 100 watts through the entire section of ductwork to be tested. The lamp shall be open so as to emit light equally in all directions perpendicular to the duct walls. The test shall be performed for entire duct system, including the hood-to-duct connection. The ductwork shall be permitted to be tested in sections, provided that every joint is tested.

Method 2 – Smoke Test

After the ductwork has been installed allow the listed sealant to cure for a minimum of 24 hours. Smoke bombs are lit and placed at the bottom of the duct system, natural upwards drafts will pull the smoke to the top of the duct system. Various length duct runs may require multiple smoke bombs. Once the smoke has reached the top of the duct run, cap the duct, making sure it's secure. Inspect all joints for leakage.

GENERAL DUCT WEIGHT

Two different material gauges are available, 20 gauge is the minimum / 18 gauge is the maximum allowable material per this listed duct. Both gauges have been tested by ETL and comply with standard UL-1978. 20 gauge is the standard material used in application with 18 inches or more to combustible surfaces. 20 gauge duct may also be wrapped using a listed duct wrap for zero clearance to combustibles, 18 gauge is required in some JHA when duct needs to be wrapped using a listed duct wrap for zero clearance to combustibles.

Weight – 20 Gauge Duct

The following formula can be used to approximate the weight of total lengths of duct for 20 GA duct (.0327 x "L" x "D"). "L" and "D" should be calculated in inches, where L is the length and D is the diameter. Example: A total length of duct is 25 ft long, 14" diameter ($.0327 \times (25' \times 12") \times 14" = 137 \text{ LBS}$).

Weight – 18 Gauge Duct

The following formula can be used to approximate the weight of total lengths of duct for 18 GA duct (.0417 x "L" x "D"). "L" and "D" should be calculated in inches, where L is the length and D is the diameter. Example: A total length of duct is 25 ft long, 14" diameter ($.0417 \times (25' \times 12") \times 14" = 175 \text{ LBS}$).

CLEANING & MAINTENANCE RECORD

Date	Service Performed

Factory Service Department
Phone: 1-866-784-6900
Fax: 1-919-554-2415