

Energy Management System Control

Installation, Operation, and Maintenance Manual



RECEIVING AND INSPECTION

Upon receiving unit, check for any interior and exterior damage, and if found, report it immediately to the carrier. Also check that all accessory items are accounted for and are damage free.

WARNING!!

Installation of this control should only be performed by a qualified professional who has read and understands these instructions and is familiar with proper safety precautions. Improper installation poses serious risk of injury due to electric shock, and other potential hazards. Read this manual thoroughly before installing or servicing this equipment. **ALWAYS** disconnect power prior to working on module.

Save these instructions. This document is the property of the owner of this equipment and is required for future maintenance. Leave this document with the owner when installation or service is complete.

TABLE OF CONTENTS

WARRANTY.....	2
INSTALLATION.....	3
Mechanical.....	3
Site Preparation	3
Assembly	3
Utility Cabinet Installation (Typical).....	3
Wall Mount Installation (Optional)	3
Duct Sensor Installation.....	4
Electrical	5
Copper Wire Ampacity	5
Variable Frequency Drive (VFD) Installation Instructions.....	6
ACTECH SMV VFD CROSS-REFERENCE TABLE.....	7
OPERATION.....	8
Start Up.....	8
Special Tools Required	8
Start Up Procedure	8
Water Wash Option.....	9
Loss of Load Relay Option	9
Component Description	10
Variable Frequency Drive	10
Temperature Control	11
Temperature Sensor	12
100% Override Timer	13
Water Wash Timers (Optional)	13
Troubleshooting	14
MAINTENANCE	15
General Maintenance	15
Every Month.....	15
Start-Up and Maintenance Documentation	16

WARRANTY

This equipment is warranted to be free from defects in materials and workmanship, under normal use and service, for a period of 12 months from date of shipment. This warranty shall not apply if:

1. The equipment is not installed by a qualified installer per the MANUFACTURER'S installation instructions shipped with the product,
2. The equipment is not installed in accordance with federal, state and local codes and regulations,
3. The equipment is misused or neglected,
4. The equipment is not operated within its published capacity,
5. The invoice is not paid within the terms of the sales agreement.

The MANUFACTURER shall not be liable for incidental and consequential losses and damages potentially attributable to malfunctioning equipment. Should any part of the equipment prove to be defective in material or workmanship within the 12-month warranty period, upon examination by the MANUFACTURER, such part will be repaired or replaced by MANUFACTURER at no charge. The BUYER shall pay all labor costs incurred in connection with such repair or replacement. Equipment shall not be returned without MANUFACTURER'S prior authorization and all returned equipment shall be shipped by the BUYER, freight prepaid to a destination determined by the MANUFACTURER.

INSTALLATION

It is imperative that this unit is installed and operated with the designed airflow and electrical supply in accordance with this manual. If there are any questions about any items, please call the service department at **1-866-784-6900** for warranty and technical support issues.

Mechanical

WARNING: DO NOT LIFT CONTROL BY WIRING COMPONENTS

Site Preparation

1. Provide clearance around installation site to safely install equipment into its final position. Supports must adequately support equipment. Refer to manufacturer's estimated weights.
2. Consider general service and installation space when locating unit.

Assembly

When the energy management system is ordered in a utility cabinet installed on the hood, there is no mechanical assembly required by the installer. If the energy management system is ordered as a wall mount configuration, the enclosure must be secured to a fixed wall near the exhaust hoods.

Utility Cabinet Installation (Typical)

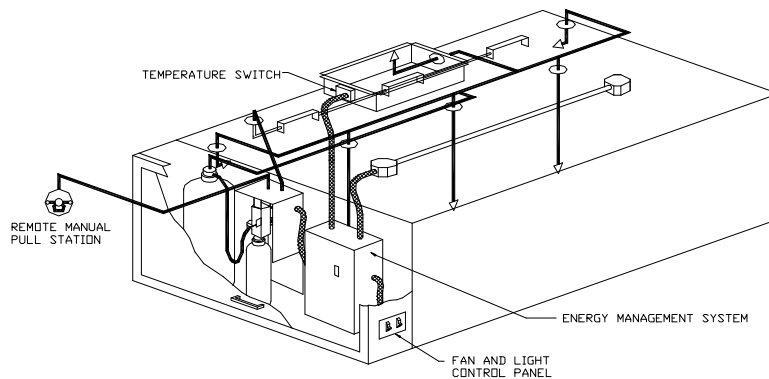

Wall Mount Installation (Optional)

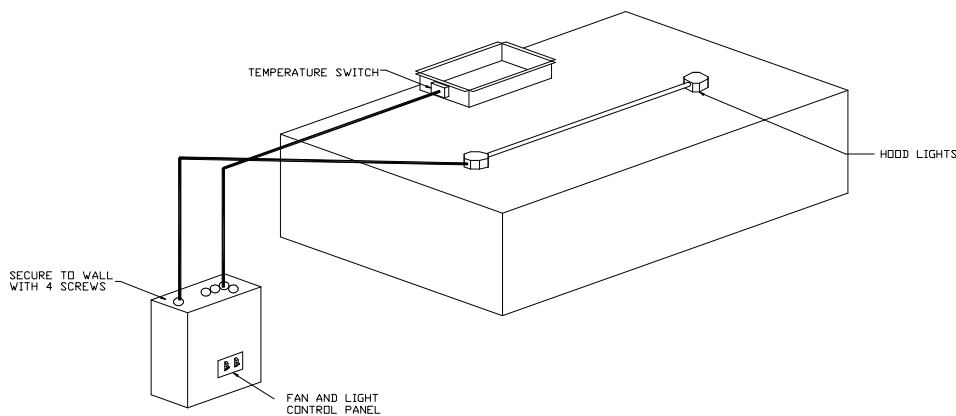

Duct Sensor Installation

When a modulating energy management system is ordered, the system consists of one duct sensor per fan. If there are multiple risers connected to a single fan, the sensor must be installed where the ducts come together before the fan unless an EMS with “**Multi-Stat**” is used. In that case, one sensor is installed in every riser. These sensors are shipped factory installed in factory assembled hood risers if there is one riser per fan. If the risers are field cut or the sensor needs to be installed at the junction of the ducts, the sensor and other components are shipped loose for field installation as shown below. A hole must be cut in the grease duct and the quick seal and sensor must be assembled as shown. The sensor has a built in junction box that wires can be run through conduit and attached to.

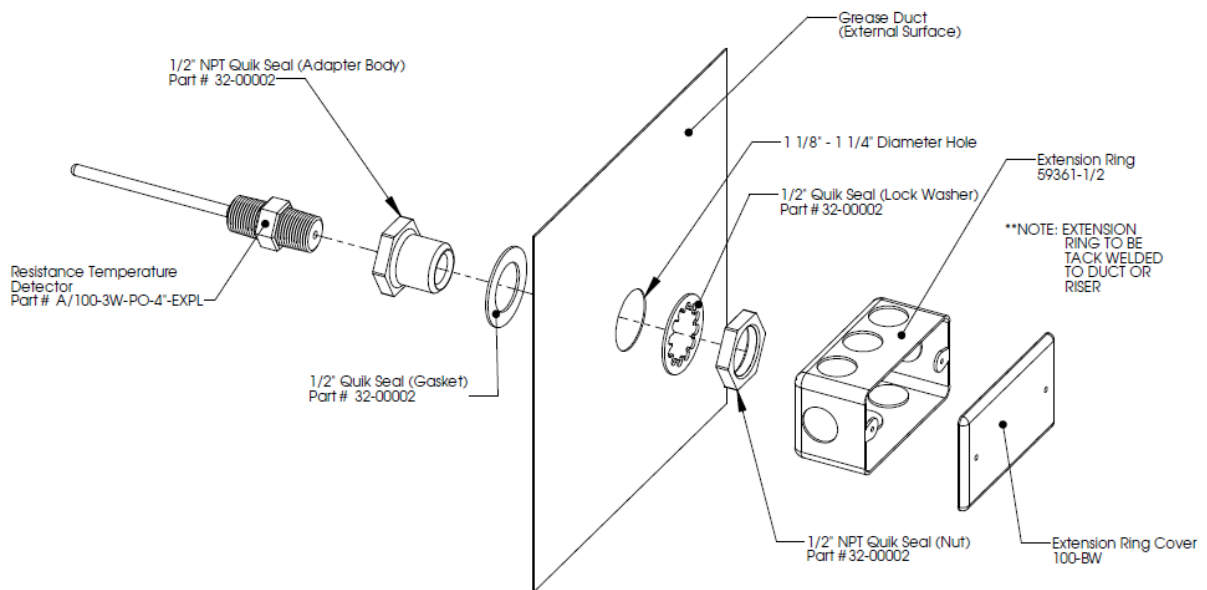

Electrical

Before connecting power to the control, read and understand the entire section of this document. As-built wiring diagrams are furnished with each control by the factory, and are attached either to the door of the unit or provided with a paperwork packet.

Electrical wiring and connections should be done in accordance with local ordinances and the National Electric Code, ANSI/NFPA70. Be sure the voltage and phase of the power supply and the wire amperage capacity is in accordance with the unit nameplate.

WARNING!!
Disconnect power before installing or servicing control. High voltage electrical input is needed for this equipment. This work should be performed by a qualified electrician.

1. Always **disconnect power** before working on or near this equipment. Lock and tag the disconnect switch or breaker to prevent accidental power up.
2. **There are multiple electrical connections** required for this control. **120VAC** should be wired to terminals **H1** and **N1**. Input power to the variable frequency drives should be wired to “**L**” series terminals. Drive input power should match the nameplate on the drive. Output power from the variable frequency drives is always **3 phase** and should match the voltage requirements of the fan motors. The output power from the drive should be connected to “**T**” series terminals.
3. Make certain that the power source is compatible with the requirements of your equipment. The energy management system wiring schematic identifies the **proper phase and voltage** of the equipment.
4. Before connecting control to power source, verify power line wiring is de-energized.
5. Secure the power cable to prevent contact with sharp objects.
6. Do not kink power cable and never allow the cable to come in contact with oil, grease, hot surfaces or chemicals.
7. If the control is a **wall-mount system**, the duct mounted temperature sensor will need to be wired in. The temperature sensor should be wired to terminal blocks as indicated on the wiring schematic. The hood lights wiring will also need to be wired to terminals “**B**” and “**W**”. The fire system micro-switch will need to be wired to terminals “**C1**”, “**AR1**”, and “**TR1**”. C1 is the common, AR1 is the armed state, and TR1 is the triggered state. Verify connections on wiring schematic.
8. Multi-strand thermostat wire must be used to wire the duct temperature sensors back to the main panel.
9. Before powering up the system, make sure that the interior of the control is free of loose debris or shipping materials.
10. **If motors are spinning in the incorrect direction, switch any two wires on the output of the variable frequency drive.**
11. If any of the original wire supplied with the system must be replaced, it must be replaced with type THHN wire or equivalent.

Copper Wire Ampacity

Wire Size AWG	Maximum Amps
14	15
12	20
10	30
8	50
6	65
4	85

IMPORTANT!!

When exhaust duct connections are located and cut in the field, duct temperature probes are shipped loose in the electrical package enclosure. These must be installed in the duct immediately above the hood for proper system operation.

Variable Frequency Drive (VFD) Installation Instructions

Input AC Power

1. Circuit breakers feeding the VFDs are recommended to be thermal-magnetic and fast acting. They should be sized as 1.5 times the input amperage of the drive. Refer to the table below.
2. Each VFD should be fed by its own breaker. If multiple VFDs are to be combined on the same breaker, each drive should have its own protection measure (fuses or miniature circuit breaker) downstream from the breaker.
3. Input AC line wires should be run in conduit from the breaker panel to the drives. AC input power to multiple VFDs can be run in a single conduit if needed.
4. The VFD should be grounded on the terminal marked PE.

STOP!

DO NOT connect incoming AC power to output terminals T1, T2, T3. Severe damage to the drive will result.

Output Power

1. Motor wires from each VFD to its respective motor **MUST** be run in a separate steel conduit away from control wiring and incoming AC power wiring to avoid noise and crosstalk between drives.
2. If the distance between the VFD and the motor exceeds 300 FT, an output reactor should be used between the VFD and the motor. The output reactor should be sized accordingly.
3. If the distance between the VFD and the motor is between 500 and 1000 FT, a dV/dT filter should be used.
4. No contactor should be installed between the drive and the motor. Operating such a device while the drive is running can potentially cause damage to the power components of the drive.
5. When a disconnect switch is installed between the drive and motor, it should only be operated when the drive is in a STOP state.

Programming

1. The Drive should be programmed for the proper motor voltage. Refer to parameter P107 in the "Component Description - Variable Frequency Drive" chapter below.
P107 is set to 0 (Low) if motor voltage is 120 VAC, 208 VAC or 400 VAC. P107 is set to 1 (High) if motor voltage is 230 VAC, 480 VAC or 575 VAC.
2. The Drive should be programmed for the proper motor overload value. Refer to parameter P108 in the "Component Description - Variable Frequency Drive" chapter below.
P108 is calculated as $\text{Motor FLA} \times 100 / \text{Drive Output Rating}$ (available in table below).

ACTECH SMV VFD CROSS-REFERENCE TABLE

M/N	Volts	1Ø input	3Ø input	HP	Input Amps 1Ø 120VAC	Input Amps 1Ø 240VAC	Output Amps	KVA	Breaker 1Ø 120VAC	Breaker 1Ø 240VAC
ESV251N01SXB531	120/240V	X		0.33	6.8	3.4	1.7	0.816	15	15
ESV371N01SXB531	120/240V	X		0.5	9.2	4.6	2.4	1.104	15	15
ESV751N01SXB531	120/240V	X		1	16.6	8.3	4.2	1.992	25	15
ESV112N01SXB531	120/240V	X		1.5	20	10	6	2.4	30	20
					Input Amps 1Ø	input Amps 3Ø			Breaker 1Ø	Breaker 3Ø
ESV371N02YXB531	240V	X	X	0.5	5.1	2.9	2.4	1.20	15	15
ESV751N02YXB531	240V	X	X	1	8.8	5	4.2	2.08	15	15
ESV112N02YXB531	240V	X	X	1.5	12	6.9	6	2.86	20	15
ESV152N02YXB531	240V	X	X	2	13.3	8.1	7	3.36	25	15
ESV222N02YXB531	240V	X	X	3	17.1	10.8	9.6	4.48	30	20
ESV402N02TXB531	240V		X	5		18.6	16.5	7.72		30
ESV552N02TXB531	240V		X	7.5		26	23	10.80		40
ESV752N02TXB531	240V		X	10		33	29	13.70		50
ESV113N02TXB531	240V		X	15		48	42	19.93		80
ESV153N02TXB531	240V		X	20		59	54	24.50		90
ESV751N04TXB531	480V		X	1		2.5	2.1	2.08		15
ESV112N04TXB531	480V		X	1.5		3.6	3	2.99		15
ESV152N04TXB531	480V		X	2		4.1	3.5	3.40		15
ESV222N04TXB531	480V		X	3		5.4	4.8	4.48		15
ESV402N04TXB531	480V		X	5		9.3	8.2	7.72		15
ESV552N04TXB531	480V		X	7.5		12.4	11	10.30		20
ESV752N04TXB531	480V		X	10		15.8	14	13.12		25
ESV113N04TXB531	480V		X	15		24	21	19.93		40
ESV153N04TXB531	480V		X	20		31	27	25.74		50
ESV183N04TXB531	480V		X	25		38	34	31.56		60
ESV223N04TXB531	480V		X	30		45	40	37.37		70
ESV751N06TXB531	600V		X	1		2	1.7	2.08		15
ESV152N06TXB531	600V		X	2		3.2	2.7	3.32		15
ESV222N06TXB531	600V		X	3		4.4	3.9	4.57		15
ESV402N06TXB531	600V		X	5		6.8	6.1	7.06		15
ESV552N06TXB531	600V		X	7.5		10.2	9	10.59		20
ESV752N06TXB531	600V		X	10		12.4	11	12.87		20
ESV113N06TXB531	600V		X	15		19.7	17	20.45		30
ESV153N06TXB531	600V		X	20		25	22	25.95		40
ESV183N06TXB531	600V		X	25		31	27	32.18		50
ESV223N06TXB531	600V		X	30		36	32	37.37		60

OPERATION

Prior to starting up or operating the energy management system, check all fasteners and wires for tightness. The VFDs (variable frequency drives) included in this system have been factory programmed at **60Hz** for high speed and **48Hz** for low speed. This results in a **20%** reduction in airflow when operation is in low speed. The VFDs are used to adjust the speed of 3 phase motors and frequency is directly proportional to airflow.

Start Up

Special Tools Required

- AC Voltage Meter
- Amperage Meter
- Standard Hand Tools

Start Up Procedure

1. Once all power, lights, and temperature sensor(s) are connected and the fans are operating in the correct direction, startup can begin. The **“Power”** light should be illuminated. If the light does not illuminate, there is not **120V** incoming power into the panel.
2. Press the **“Lights On”** switch to energize the hood lights. If the lights do not come on, install light bulbs or check the lighting circuit.
3. Press the **“Fans On”** switch to energize the VFDs and fans. The fans take a few seconds to come up to speed. The VFDs should all indicate **48Hz** and the **“Fans On”** indicator light should illuminate. This indicates that the fans are operating on low speed. If the supply fan drive does not power up, the fire system micro-switch is not in the armed position or has not been connected properly. A fire system distributor should service the micro-switch or arm the fire system.
4. Press the **“100% Airflow”** button on the control interface. The **“100% Airflow Override”** indicator light should illuminate and all of the VFDs should indicate **60Hz or high speed**. This indicates that the fans are operation on high speed. The fans should stay at this speed for a factory set time of **30 minutes**. This time is adjustable as described in the timer component section. After the time interval expires, the drives should return to **48Hz or low speed**. The high speed and low speed frequencies are adjustable as described in the VFD component section.
5. Turn on the cooking appliance and allow it to reach idle temperature. If the fan switch is in the **“OFF”** position, the fans should automatically be energized as the cooking appliance heats up. The low temperature set point in the temperature control should be set to approximately 5 degrees above kitchen ambient temperature. If this value must be changed, there are other values that must be changed as well. See the temperature control component section for further details.
6. **The appliances running in idle mode should not make the energy management system operate at high speed.** The fans should modulate during the cooking process.
7. If the fans go to high speed while the cooking appliances are idling, the high temperature set point should be adjusted. **Increase** the high temperature set point. If this value must be changed, there are other values that must be changed as well. See the temperature control component section for further details.

Operation Chart

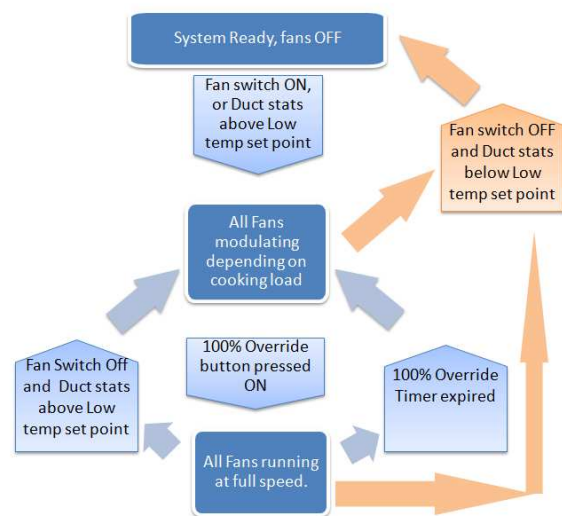

8. If the fans **never or rarely go to high speed** while cooking is taking place, the high temperature set point should be adjusted. **Decrease** the high temperature set point. If this value must be changed, there are other values that must be changed as well. See the temperature control component section for further details.
9. Start-up is complete.

Water Wash Option

1. If the control contains the water wash option, there are 2 timers that control the water wash spray and the surfactant injection. The wash timer is a fleeting off timer and is set to 3 minutes from the factory. The surfactant timer is an asynchronous timer that is factory set for 1 second of injection with a 1 minute off time. The injection occurs at the start of each minute.
2. To operate the wash cycle, simply turn the fan switch on and then back off. The wash cycle energizes automatically.
3. After the time expires that is on the wash timer, the cycle ends.
4. Hood filters **MUST** remain in place during the wash cycle.

Loss of Load Relay Option

1. If the control contains the loss of load relay functionality for supply-exhaust interlocks, this must be configured in the field after a test and balance has been performed on the fans. When this option is selected, the supply fan must prove airflow first, followed by the exhaust fan. Once the exhaust fan airflow is proven, the supply fan burner can be ignited if equipped.
2. Parameter P145 on the drive controls this functionality. P145 is configured for loss of power load on the drive. P145 sets the percentage of nameplate amperage that would be considered a loss of load. For example, if nameplate VFD amperage is 10 amps and P145 is set to 60%, then a loss of load condition would occur if the fan motor amperage drops below 6 amps.
3. To set this value properly, the fans must be run in their low speed condition. (15 Hz for self cleaning hoods and 48 Hz for non self cleaning applications). While the fans are operating at low speed, the fan amperage must be measured. This is the percentage of nameplate amperage that must be entered into P145.
4. This value may need to be adjusted down a few percentage points to prevent nuisance trips.
5. To test this system, remove the belts from either the supply fan or the exhaust fan to simulate a loss of airflow. The system should shut all fans down within 10 seconds.

Component Description

Variable Frequency Drive

Variable frequency drives change the speed of 3 phase motors by changing the frequency signal sent to the motor. There is one variable frequency drive for each fan in this system. The drives are factory set to operate at 60Hz on high speed and 48Hz on low speed. This difference in speed produces a 20% CFM reduction on low speed. In some applications, and for test and balance reasons, the high and low speeds will need to be adjusted.



Variable Frequency Drive Parameters

Variable frequency drive parameters can be changed with the buttons on the face of the drive. Only parameters P103, P132, P133, P136, P140, P144, P152, P160 and P161 should be manipulated. To enter the PROGRAM mode to access the parameters:

1. Press the Mode (M) button. This will activate the password prompt (PASS).
2. Use the Up and Down buttons to scroll to the password value (the factory default password is "0225") and press the Mode (M) button. Once the correct password is entered, the display will read "P100", which indicates that the PROGRAM mode has been accessed at the beginning of the parameter menu.
3. Use the Up and Down buttons to scroll to the desired parameter number (for example, parameter 160).
4. Once the desired parameter is found, press the Mode (M) button to display the present parameter setting. The parameter value will begin blinking, indicating that the present parameter setting is being displayed. The value of the parameter can be changed by using the Up and Down buttons.
5. Pressing the Mode (M) button will store the new setting and also exit the PROGRAM mode. To change another parameter, press the Mode (M) button again to re-enter the PROGRAM mode. If the Mode button is pressed within 1 minute of exiting the PROGRAM mode, the password is not required to access the parameters. After one minute, the password must be entered in order to access the parameters again.

The high speed frequency should only be adjusted to achieve design airflow rates or to fix exhaust problems while cooking is taking place. Each time the high speed frequency is adjusted, the low speed(s) should also be adjusted. The manufacturer suggests a 20% airflow reduction. For example, if the high speed frequency is set at 50 Hz, then low speed should be set at 40 Hz (50×0.8). All supply and exhaust drives should be adjusted to the same values.

Parameter P103, P133, P136 and P161 on the drives control the high speed frequency. All of these parameters must be set to the same value.

Parameter P152 is related to the high speed frequency and is a scaling factor. For a supply fan drive, this parameter should be set to the same value as the group above. For an exhaust fan drive, this value should be set to the high speed frequency times the number of exhaust fans. For example, if the high speed frequency is 35 Hz and there are 2 exhaust drives, this parameter should be set to 70 Hz.

Parameter P160 on the exhaust drive controls the low speed exhaust frequency. This should be set to 20% less than the high speed frequency.

Parameter P132 on the exhaust fan drives is set to 15 Hz for the water wash option. This will keep the hoods running at a low speed during the wash cycle. This prevents water from escaping through the hood filters. This should be adjusted as needed to prevent water from exiting hood.

Examples of exhaust and supply VFD parameters are shown in the tables above. To reverse motor rotation, any 2 legs of the output of the drive should be switched.

Temperature Control

There is a digital temperature control shipped with these systems. There is one control for every exhaust fan being controlled by the EMS. The temp control is multi-functional and includes input from the duct mounted RTD, relay contacts driven by programmable alarms, and a signal output to speed up and slow down the VFDs.



There are two factory set ranges of temperature controls. The low temp range is factory programmed for 400-450°F rated hoods. It is pre-programmed to turn the fans on automatically at 85°F and to send the fans to high speed at a 90°F duct temperature. The high temp range is factory programmed for 600-700°F rated hoods. It is pre-programmed to turn the fans on automatically at 85°F and to send the fans to high speed at a 130°F duct temperature.

It is the manufacturer's recommendation that the low temp set point (factory set at 85°F) be set to 5°F above the kitchen ambient temperature. Settings less than 5°F above ambient can cause the fans to stay operating for hours after the cooking appliances have been turned off. Settings of more than 5°F above kitchen ambient can cause the fans to cycle on and off many times after the cooking appliances have been turned off. When this value needs to be changed, parameters A1-H and SV-L must all be set to the new value. P must be changed as well as discussed below.

The high temp set point must be fine tuned to the application. A setting of 90°F will work well for ovens and griddles, while 130 will work well for char-broilers. There may be situations where a combination of these appliances or different appliances are used and the high temp set point will need to be changed. When this value needs to be changed, parameters AL2 and SV-H must all be set to the new value. P must be changed as well as discussed below.

If either the low temp set point or the high temp set point require a change, the ramping parameter "P" will need to be changed as well. This value relates those two set points and drives the VFD. Use the following formula to calculate P.

$$P = 100 * (AL2 - A1-H) / 200$$

The default display of the temperature control is PV (process value). To modify all other parameters, follow these instructions:

1. To change the SV (set value), simply use the up and down arrow buttons. The SV must match A1-H.
2. To modify the level 1 parameters, press and hold the "SEL" button for approximately 1 second. This will bring up the A1-H parameter. Momentarily press the "SEL" button to bring up the value of that parameter. Use the Up and Down buttons to modify the value. Once the desired value is found, press the "SEL" button once more.
3. Press the Up or Down button to move to the next parameter. Only A1-H and AL2 are located in the level 1 parameters.
4. To move to Level 2 parameters, press and hold the "SEL" button for approximately 3 seconds. This will allow access to P. P should be calculated based on AL2 and A1-H.
5. To move to the Level 3 parameters, press and hold the "SEL" button for approximately 5 seconds. This will allow access to SV-L and SV-H. SV-L and SV-H are the upper and lower limits of SV.

Low Temp Control

Parameter	Factory Setting
SV	85
LEVEL 1	
A1-H	85
AL2	90
LEVEL 2	
P	2.5
LEVEL 3	
SV-L	85
SV-H	90

High Temp Control

SV	85
LEVEL 1	
A1-H	85
AL2	130
LEVEL 2	
P	22.5
LEVEL 3	
SV-L	85
SV-H	130



Parameter Definitions

Parameter	Definition
PV	Process Value
SV	Set Value
A1-H	Alarm 1 Set Value
AL2	Alarm 2 Set Value
P	Proportional Band
SV-L	Set Value Lower Limit
SV-H	Set Value Upper Limit
SV-H	130

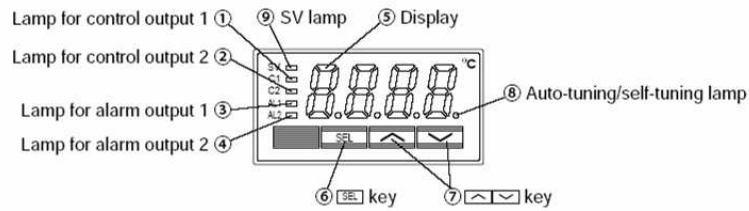
Temperature Control Names and Functions



Type: PXR3

- | | |
|--|---|
| <p>① Lamp for control output 1
Lights up while control output 1 stays ON.</p> <p>② Lamp for control output 2
Lights up while control output 2 stays ON.</p> <p>③ Lamp for alarm output 1 (option)
Lights up when alarm output 1 is actuated. Flickers under ON-delay operation.</p> <p>④ Lamp for alarm output 2 (option)
Lights up when alarm output 2 is actuated. Flickers under ON-delay operation.</p> <p>⑤ Display
Displays the PV (process value) or SV (set value). When setting a parameter, its name or its value appears.</p> | <p>⑥ SEL key
Used to switch the PV display to/from the SV display and select a parameter block and a parameter, and register a set value.</p> <p>⑦   keys
Used to change the SV, call parameters, and change parameter values.</p> <p>⑧ Auto-tuning/self-tuning lamp
Flickers under an auto-tuning or self-tuning operation.</p> <p>⑨ SV lamp
Displays the PV (process value) in normal condition (while the lamp stays out). Press the SEL key to light up the SV lamp and display the SV (set value). Note that the lamp stays out while parameters and data are displayed.</p> |
|--|---|

Temperature Sensor

The temperature sensor used in modulating systems is a digital RTD (Resistance Temperature Detector). The sensor gives constant feedback to the temperate control. There is usually one sensor per exhaust fan. If multiple hood risers are connected to one fan, this sensor must be installed where the two ducts converge and prior to the fan.

If an EMS with "**Multi-Stat**" is used, one sensor is installed in every riser. The maximum value of all sensors associated with one exhaust fan is used to modulate that fan.

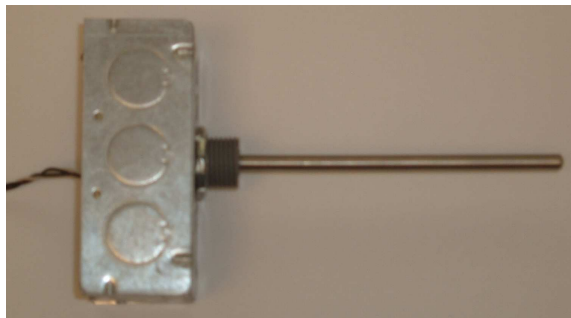

100% Override Timer

The timer included in this package is energized when the “100% Airflow” button is depressed. The timer holds the fan speed on high for a set amount of time. Once the time period expires, the fans operate based on the duct temperature switch. This time period is factory set at **30 minutes**, but is adjustable on an application specific basis. The time range adjustment is from .05 seconds to 60 hours. The small top dial on the timer allows main unit adjustments. This dial can be set to 1, 3, 10, or 60 seconds(s), minutes(m), or hours(h). Once the small top dial is set, the large red dial adjusts the percentage of the middle dial. For example, if the small top dial is set to 1 hr, and the large red dial is set to .25, the selected time period would result in 15 (1 hr * .25 = 15 minutes) minutes. The large dial is a percentage of the small dial. **The red switch on the right side of the face of the timer should NOT be adjusted and is factory set to the bottom position (on delay).**



Water Wash Timers (Optional)

The water wash option includes two timers that ship in the main control panel. These timers control the wash cycle length and the surfactant injection.

The timer shown to the right is the wash cycle timer. The wash cycle timer is a fleeting off timer and is triggered by turning the fan switch to the “OFF” position. The time is factory set to 3 minutes but is adjustable on an application specific basis. It has a range of .5 to 10 minutes and is adjusted by simply rotating the large red dial.

The time shown on the right is the surfactant injection timer. The surfactant timer is a asynchronous on-off timer. This means that it cycles contacts on and off for adjustable time ranges. The timer is factory set to inject surfactant for 1 second and every minute. The interval time (time when not injecting) is set by the top two dials. The small top dial on the timer allows main unit adjustments. This dial can be set to 1, 3, 10, or 60 seconds(s), minutes(m), or hours(h). Once the small top dial is set, the top, large red dial adjusts the percentage of the middle dial. For example, if the small top dial is set to 1 minute, and the large red dial is set to 1.0, the selected time period would result in 1 (1 minute * 1.0 = 1 minute) minute. The large dial is a percentage of the small dial.



The surfactant injection time is set by the bottom two dials. The small bottom dial on the timer allows main unit adjustments. This dial can be set to 1, 3, 10, or 60 seconds(s), minutes(m), or hours(h). Once the small bottom dial is set, the bottom, large red dial adjusts the percentage of the middle dial. For example, if the small bottom dial is set to 1 second, and the large red dial is set to 1.0, the selected time period would result in 1 (1 second * 1.0 = 1 second) second. The large dial is a percentage of the small dial.



The red switch on the right side of the face of the timer should NOT be adjusted and is factory set to the bottom position (beginning of time period).

Troubleshooting

The following table lists causes and corrective actions for possible problems with this control. Review this list prior to consulting manufacturer.

Troubleshooting Chart

Problem	Potential Cause	Corrective Action
Smoke Rollout of Hood at High Speed or 100% Operation	High speed set too low	Increase exhaust and supply fan v frequency drive high speed set poi
	Improper hood installation	Check for proper hood overhang, d improper hood design
Smoke Rollout of Hood at Low Speed Operation	Low Speed set too low	Increase exhaust and supply fan v frequency drive low speed set poi
	Improper hood installation	Check for proper hood overhang, d improper hood design
Fans Never Go to High Speed	Dirty temperature sensor	Clean grease and dirt from sensor
	High Set Point on Temperature Control Set Too High	Decrease high temperature set po temperature control. This will forc high speed at a lower exhaust tem
Fans Never Go to Low Speed	Low Temperature set point on temperature control set too high	Reduce low temp set point on tem control by 2 degrees. This will allo equipment to further cool and prev Repeat this step until satisfied.
Fans Spin Wrong Direction	VFD Output wiring incorrect	Switch any two leads on the output
Exhaust Fan On and Supply Fan will not Start	Broken supply fan belt	Replace fan belt
	Fire system not armed	Fire system distributor must arm fi
Power Light Not On	No power into enclosure	Check main 120V power supply
100% Override Button Does Not Increase Exhaust	Exhaust already at 100%	Proper operation
	Loose wiring connection	Check override button, timer, and wiring connections
Fan Switch On but No Fans Come On	Broken fan belt	Replace fan belt
	Variable frequency drive error	Clear error on variable frequency d drive manual.
	Loose wiring connection	Check fan switch and terminal bloc connections
Light Switch On but No Lights Come On	Light bulbs are blown	Replace hood light bulbs
	Loose wiring connection	Check light switch and light termin connections
Water Wash Cycle Never Runs	Improperly set Wash Timer (Water Wash Systems Only)	Fleeting Off Timer should be set to greater then 0. LED on face of tim while in wash cycle.
Water Wash Hood not staying clean	Surfactant Not Being Injected	Asynchronous surfactant timer set Increase injection time or decrease
	Wash time not set high enough	Increase Wash time
	Surfactant container Empty	Replace Surfactant Container

MAINTENANCE

To guarantee trouble free operation of this control, the manufacturer suggests following these guidelines. Most problems associated with unit failures are directly related to poor service and maintenance.

Please record any maintenance or service performed on this equipment in the documentation section located at the end of this manual.

WARNING: DO NOT ATTEMPT MAINTENANCE ON THIS CONTROL UNTIL THE ELECTRICAL SUPPLY HAS BEEN COMPLETELY DISCONNECTED

General Maintenance

1. Control enclosure should be kept clean and free from any grease or dirt build-up.
2. All fasteners should be checked for tightness each time maintenance checks are performed prior to restarting unit.
3. Control enclosure door panel should be securely closed after maintenance to prevent tampering or electrical shock.

Every Month

1. **Temperature sensor(s)** in exhaust hood riser(s) need to be cleaned by wiping any grease or dust build-up from probe with a clean cloth. A clean sensor ensures that the temperature switch will quickly respond to changes in exhaust air temperature.
2. Check all fasteners, sensors, and electrical connections for proper tightness and continuity.

