

Installation, Operation, and Maintenance Manual

EMSp⁺plus™

RECEIVING AND INSPECTION

Upon receiving unit, check for any interior and exterior damage, and if found, report it immediately to the carrier. Also check that all accessory items are accounted for and are damage free.

WARNING!!

Installation of this control should only be performed by a qualified professional who has read and understands these instructions and is familiar with proper safety precautions. Improper installation poses serious risk of injury due to electric shock and other potential hazards. Read this manual thoroughly before installing or servicing this equipment. **ALWAYS** disconnect power prior to working on module.

Save these instructions. This document is the property of the owner of this equipment and is required for future maintenance. Leave this document with the owner when installation or service is complete.

TABLE OF CONTENTS

WARRANTY.....	2
INSTALLATION.....	3
Mechanical.....	3
Site Preparation.....	3
Assembly.....	3
Utility Cabinet Installation (Typical).....	3
Wall Mount Installation (Optional).....	3
Duct Sensor Installation.....	4
Electrical.....	5
Copper Wire Ampacity.....	5
Variable Frequency Drive (VFD) Installation Instructions.....	6
OPERATION.....	8
Start-Up.....	8
Special Tools Required.....	8
Start Up Procedure.....	8
Functionality.....	10
Individual Fan Control.....	10
Preparation Time Mode.....	11
Hood Lights.....	11
Self-Cleaning function (Optional).....	11
Fan Proving Interlock (i.e. Loss of Load Interlock/Airflow Fault Interlock).....	12
2 nd Stage Cooling Interlock for RTU or Dedicated Make-Up Air with DX Coil.....	13
BACNET DDC Controls (Optional).....	13
Configuration.....	13
Security.....	14
Setup Options.....	15
Scheduling.....	25
Status and Diagnostics.....	28
Alarms.....	28
Status Page.....	28
Fan Status Page.....	28
Drive Diagnostics.....	29
Temperature Sensors Reading Page.....	29
CORE.....	30
Component Description.....	31
Variable Frequency Drive.....	31
Variable Frequency Drive Parameters.....	31
Temperature Sensor.....	32
Room Temperature Sensor.....	32
Programmable Logic Controller (PLC).....	32
Touch Screen Interface.....	32
ANNEX A: BACNET Objects.....	33
Troubleshooting.....	37
MAINTENANCE.....	38
General Maintenance.....	39
Self-Cleaning.....	39
Start-Up and Maintenance Documentation.....	40

WARRANTY

This equipment is warranted to be free from defects in materials and workmanship, under normal use and service, for a period of 12 months from date of shipment. This warranty shall not apply if:

1. The equipment is not installed by a qualified installer per the MANUFACTURER'S installation instructions shipped with the product,
2. The equipment is not installed in accordance with federal, state and local codes and regulations,
3. The equipment is misused or neglected,
4. The equipment is not operated within its published capacity,
5. The invoice is not paid within the terms of the sales agreement.

The MANUFACTURER shall not be liable for incidental and consequential losses and damages potentially attributable to malfunctioning equipment. Should any part of the equipment prove to be defective in material or workmanship within the 12-month warranty period, upon examination by the MANUFACTURER, such part will be repaired or replaced by MANUFACTURER at no charge. The BUYER shall pay all labor costs incurred in connection with such repair or replacement. Equipment shall not be returned without MANUFACTURER'S prior authorization and all returned equipment shall be shipped by the BUYER, freight prepaid to a destination determined by the MANUFACTURER.

INSTALLATION

It is imperative that this unit is installed and operated with the designed airflow and electrical supply in accordance with this manual. If there are any questions about any items, please call the service department at **1-866-784-6900** for warranty and technical support issues.

Mechanical

WARNING: DO NOT LIFT CONTROL BY WIRING COMPONENTS

Site Preparation

1. Provide clearance around installation site to safely install equipment into its final position. Supports must adequately support equipment. Refer to manufacturer's estimated weights.
2. Consider general service and installation space when locating unit.

Assembly

When the energy management system is ordered in a utility cabinet installed on the hood, there is no mechanical assembly required by the installer. If the energy management system is ordered as a wall mount configuration, the enclosure must be secured to a fixed wall near the exhaust hoods.

Utility Cabinet Installation (Typical)

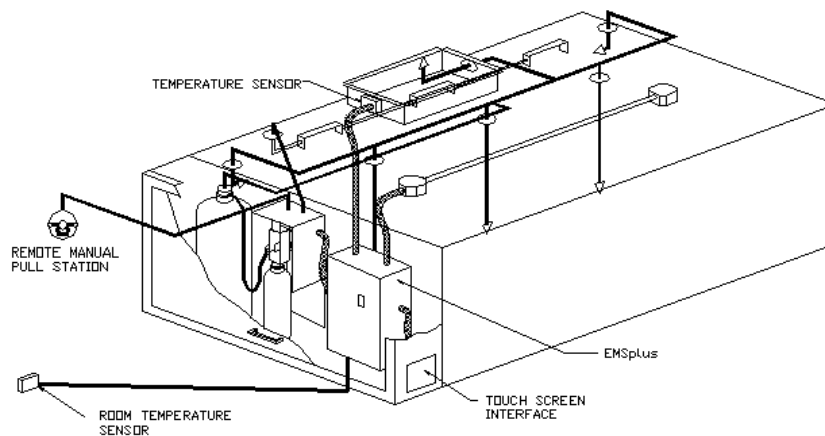

Wall Mount Installation (Optional)

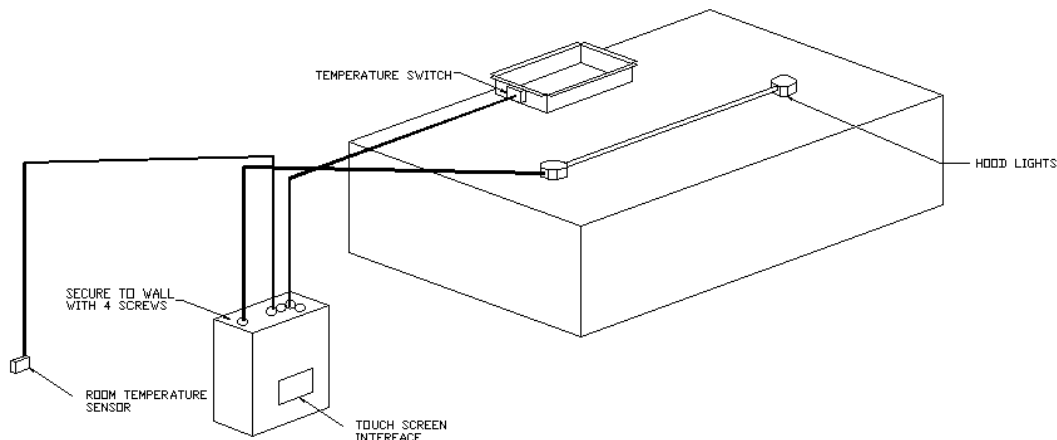

Duct Sensor Installation

When an EMSplus is ordered, the system consists of one duct sensor per riser. These sensors are shipped factory installed in factory assembled hood risers. If the risers are field cut, the sensor and other components are shipped loose for field installation as shown below. A hole must be cut in the grease duct, and the quick seal and sensor must be assembled as shown below. A 3-wire RTD cable, run in conduit, should be used to wire the sensors back to the controller.

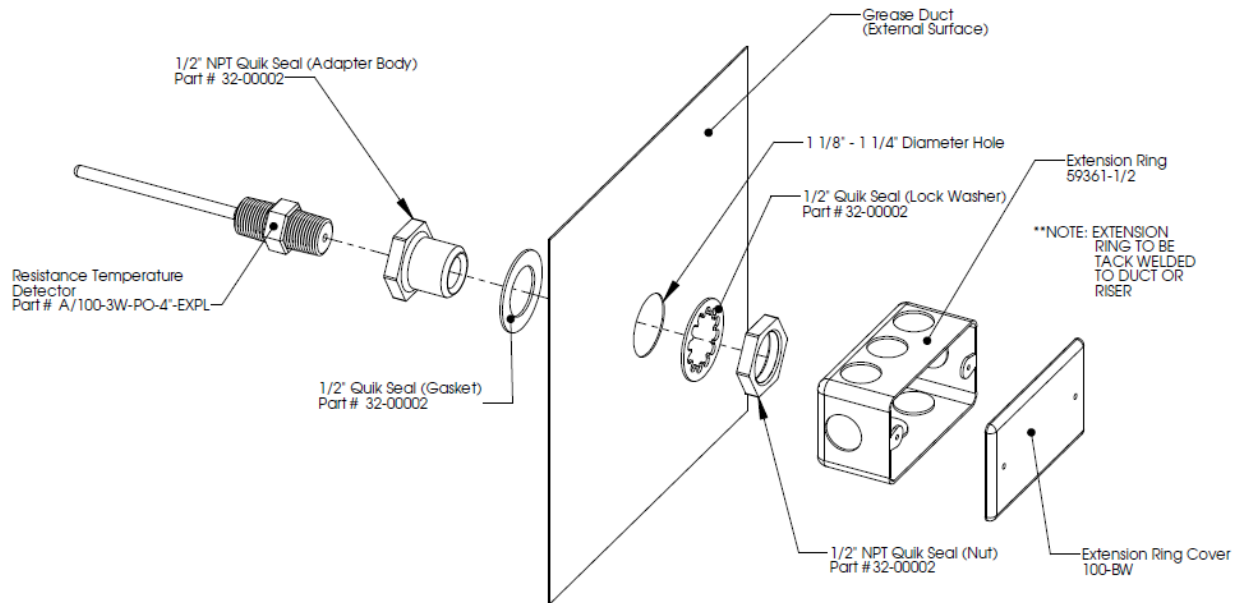

Electrical

Before connecting power to the control, read and understand the entire section of this document. As-built wiring diagrams are furnished with each control by the factory and are attached either to the door of the unit or provided with a paperwork packet.

Electrical wiring and connections should be done in accordance with local ordinances and the National Electric Code, ANSI/NFPA70. Be sure the voltage and phase of the power supply and the wire amperage capacity is in accordance with the unit nameplate.

WARNING!!

Disconnect power before installing or servicing control. High voltage electrical input is needed for this equipment. This work should be performed by a qualified electrician.

1. Always **disconnect power** before working on or near this equipment. Lock and tag the disconnect switch or breaker to prevent accidental power up.
2. **There are multiple electrical connections** required for this control. **120VAC** should be wired to terminals **H1** and **N1**. Input power to the variable frequency drives should be wired to “**L**” series terminals. Drive input power should match the nameplate on the drive. Output power from the variable frequency drives is always **3 phase** and should match the voltage requirements of the fan motors. The output power from the drive should be connected to “**T**” series terminals.
3. Make certain that the power source is compatible with the requirements of your equipment. The energy management system wiring schematic identifies the **proper phase and voltage** of the equipment.
4. Before connecting control to power source, verify power line wiring is de-energized.
5. Secure the power cable to prevent contact with sharp objects.
6. Do not kink power cable and never allow the cable to come in contact with oil, grease, hot surfaces or chemicals.
7. If the control panel is wall-mounted, the duct mounted temperature sensors will need to be wired in the field. The temperature sensor should be wired to terminal blocks as indicated on the wiring schematic. The hood lights wiring will also need to be wired to terminals “**B**” and “**W**”. The fire system micro-switch will need to be wired to terminals “**C1**”, “**AR1**”, and “**TR1**”. C1 is the common, AR1 is the armed state, and TR1 is the triggered state. Verify connections on wiring schematic.
8. Multi-strand thermostat wire (brown, brown, black) must be used to wire the Duct Temperature sensors and the room temperature sensor back to the main panel.
9. Before powering up the system, make sure that the interior of the control is free of loose debris or shipping materials.
10. If any of the original wire supplied with the system must be replaced, it must be replaced with type THHN wire or equivalent.

Copper Wire Ampacity

Wire Size AWG	Maximum Amps
14	15
12	20
10	30
8	50
6	65
4	85

IMPORTANT!!

When exhaust duct connections are located and cut in the field, duct temperature probes are shipped loose in the electrical package enclosure. These must be installed in the duct immediately above the hood for proper system operation.

Variable Frequency Drive (VFD) Installation Instructions

Input AC Power

1. Circuit breakers feeding the VFDs are recommended to be thermal-magnetic and fast acting. They should be sized 1.5 times the input amperage of the drive. Refer to the table below.
2. Each VFD should be fed by its own breaker. If multiple VFDs are to be combined on the same breaker, each drive should have its own protection measure (fuses or miniature circuit breaker) downstream from the breaker.
3. Input AC line wires should be run in conduit from the breaker panel to the drives. AC input power to multiple VFDs can be run in a single conduit if needed.
4. The VFD should be grounded on the terminal marked PE.

STOP!

DO NOT connect incoming AC power to output terminals T1, T2, T3. Severe damage to the drive will result.

Output Power

1. Motor wires from each VFD to its respective motor **MUST** be run in a separate steel conduit away from control wiring and incoming AC power wiring to avoid noise and crosstalk between drives.
2. If the distance between the VFD and the motor exceeds 250 FT, an output reactor should be used between the VFD and the motor. The output reactor should be sized accordingly.
3. If the distance between the VFD and the motor is between 500 and 1000 FT, a dV/dT filter should be used.
4. No contactor should be installed between the drive and the motor. Operating such a device while the drive is running can potentially cause damage to the power components of the drive.
5. When a disconnect switch is installed between the drive and motor, it should only be operated when the drive is in a STOP state.

Programming

1. Most VFD parameters are preprogrammed at the factory when proper information about the fan motors is provided. However the 2 parameters below should be verified in the field during startup.
2. The Drive should be programmed for the proper motor voltage. Refer to parameter P107 in the "Component Description - Variable Frequency Drive" chapter below.
P107 is set to 0 (Low) if motor voltage is 120 VAC, 208 VAC or 400 VAC. P107 is set to 1 (High) if motor voltage is 230 VAC, 480 VAC or 575 VAC.
3. The Drive should be programmed for the proper motor overload value. Refer to parameter P108 in the "Component Description - Variable Frequency Drive" chapter below.
P108 is calculated as $\text{Motor FLA} \times 100 / \text{Drive Output Rating}$ (available in table below).

ACTECH SMV VFD CROSS-REFERENCE TABLE

M/N	Volts	1Ø input	3Ø input	HP	Input Amps 1Ø 120VAC	Input Amps 1Ø 240VAC	Output Amps	KVA	Breaker 1Ø 120VAC	Breaker 1Ø 240VAC
ESV251N01SXB531	120/240V	X		0.33	6.8	3.4	1.7	0.816	15	15
ESV371N01SXB531	120/240V	X		0.5	9.2	4.6	2.4	1.104	15	15
ESV751N01SXB531	120/240V	X		1	16.6	8.3	4.2	1.992	25	15
ESV112N01SXB531	120/240V	X		1.5	20	10	6	2.4	30	20
					Input Amps 1Ø	Input Amps 3Ø			Breaker 1Ø	Breaker 3Ø
ESV371N02YXB531	240V	X	X	0.5	5.1	2.9	2.4	1.20	15	15
ESV751N02YXB531	240V	X	X	1	8.8	5	4.2	2.08	15	15
ESV112N02YXB531	240V	X	X	1.5	12	6.9	6	2.86	20	15
ESV152N02YXB531	240V	X	X	2	13.3	8.1	7	3.36	25	15
ESV222N02YXB531	240V	X	X	3	17.1	10.8	9.6	4.48	30	20
ESV402N02TXB531	240V		X	5		18.6	16.5	7.72		30
ESV552N02TXB531	240V		X	7.5		26	23	10.80		40
ESV752N02TXB531	240V		X	10		33	29	13.70		50
ESV113N02TXB531	240V		X	15		48	42	19.93		80
ESV153N02TXB531	240V		X	20		59	54	24.50		90
ESV751N04TXB531	480V		X	1		2.5	2.1	2.08		15
ESV112N04TXB531	480V		X	1.5		3.6	3	2.99		15
ESV152N04TXB531	480V		X	2		4.1	3.5	3.40		15
ESV222N04TXB531	480V		X	3		5.4	4.8	4.48		15
ESV402N04TXB531	480V		X	5		9.3	8.2	7.72		15
ESV552N04TXB531	480V		X	7.5		12.4	11	10.30		20
ESV752N04TXB531	480V		X	10		15.8	14	13.12		25
ESV113N04TXB531	480V		X	15		24	21	19.93		40
ESV153N04TXB531	480V		X	20		31	27	25.74		50
ESV183N04TXB531	480V		X	25		38	34	31.56		60
ESV223N04TXB531	480V		X	30		45	40	37.37		70
ESV751N06TXB531	600V		X	1		2	1.7	2.08		15
ESV152N06TXB531	600V		X	2		3.2	2.7	3.32		15
ESV222N06TXB531	600V		X	3		4.4	3.9	4.57		15
ESV402N06TXB531	600V		X	5		6.8	6.1	7.06		15
ESV552N06TXB531	600V		X	7.5		10.2	9	10.59		20
ESV752N06TXB531	600V		X	10		12.4	11	12.87		20
ESV113N06TXB531	600V		X	15		19.7	17	20.45		30
ESV153N06TXB531	600V		X	20		25	22	25.95		40
ESV183N06TXB531	600V		X	25		31	27	32.18		50
ESV223N06TXB531	600V		X	30		36	32	37.37		60

OPERATION

Prior to starting up or operating the EMSplus, check all fasteners and wires for tightness. The VFDs (variable frequency drives) included in this system have been factory programmed at **60Hz** for high speed and **48Hz** for low speed. This results in a **20%** reduction in airflow when operation is in low speed. The VFDs are used to adjust the speed of 3 phase motors and frequency is directly proportionate to airflow.

Start-Up

Special Tools Required

- AC Voltage Meter
- Amperage Meter
- Standard Hand Tools

Start Up Procedure

1. Once all power, lights, inputs, outputs and temperature sensor(s) are connected, startup can begin. Before applying power to the EMSplus, verify that breaker CB-01 is turned off. Apply power. Turn CB-01 ON. The Touch Screen Panel will power up and beep. If that is not the case, check all power connections.
2. Verify that the COM indicator Light on top of the Touch Screen Panel is lighted green. If that is not the case, verify that the serial cable going from the back of the panel to the Controller is properly plugged in. Make sure the Grey connector is labeled "HMI" on the side of the Touch Screen Panel and "PLC" on the side of the controller. If there is still no communication, cycle power to the Unit once more by turning CB-01 ON and OFF.

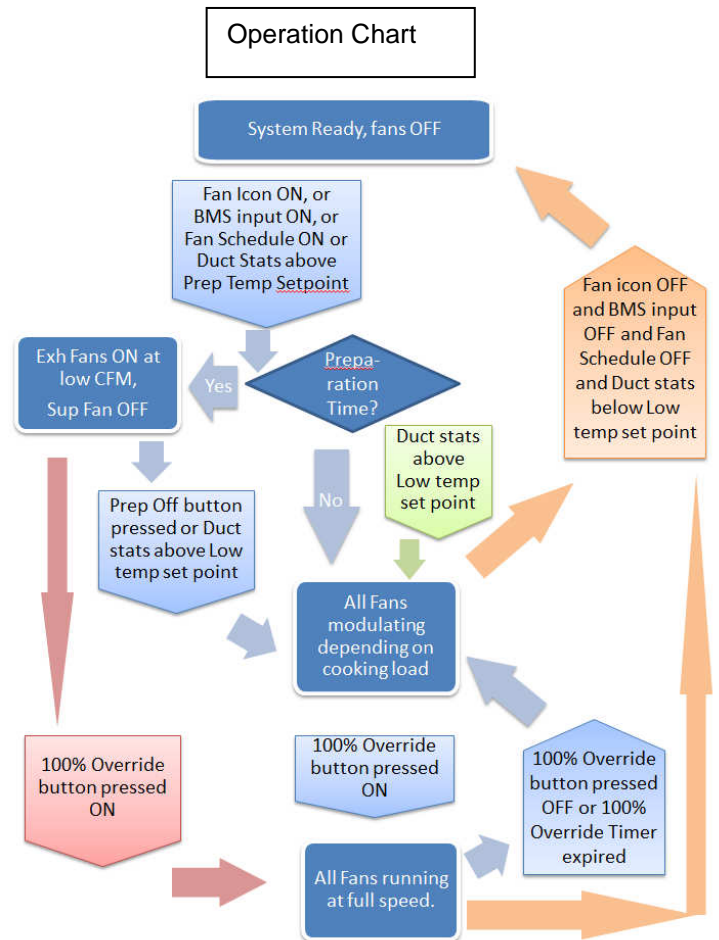
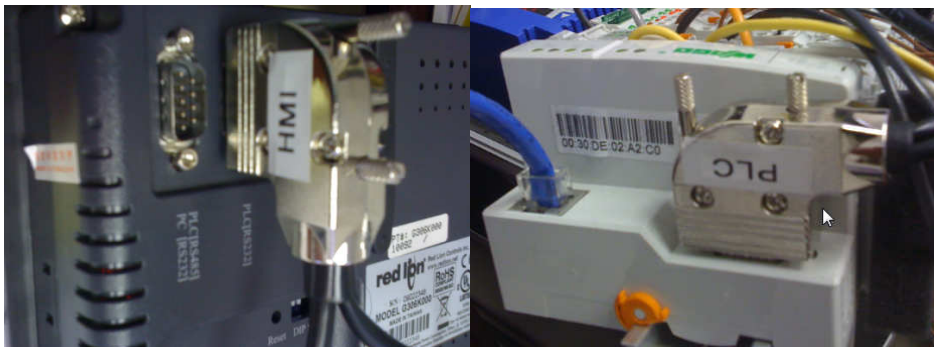

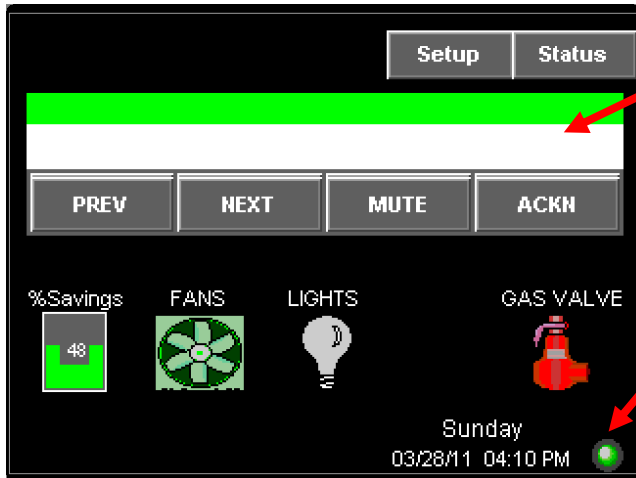

Verify that there are no alarm messages displayed here. If there are, press ACKN to make them disappear after they are resolved. Press MUTE to silence the alarm.

Verify that the "PLC Running Light" is green. If it is not, the PLC is not running and the configuration of the PLC was not properly completed.

3.

4. Press the **Lights** icon on the Touch Screen to energize the hood lights. If the lights do not come on, make sure the light bulbs are installed or check the lighting circuit. If the system is configured for multiple light circuits, pressing the **Lights** icon will take you to the **Hood Lights Control** Page. From there, press the **All Lights** icon to energize all light circuits.



5. Press the **Fans** icon on the Touch Screen to energize the VFD and fan. If the Preparation Mode is enabled, press the Prep OFF button to run in normal mode.



If there are multiple fans on the job and the **Individual Fan Control** is selected (factory default), pressing the **Fans** icon will take you to the **Exhaust Fan Control** Page. From there, press the **All Fans** icon to energize all VFDs and Fans. If the Preparation Mode is enabled, press the Prep OFF button to run in normal mode.



The fans take a few seconds to come up to speed. The VFDs should all indicate **48Hz** and the **All Fans** indicator light should be green and "turning". This indicates that the fans are operating on low speed. If the supply fan drive does not ramp up, verify that there isn't a fire Condition Alarm on the Touch Screen. If that's the case, the fire system might be tripped or not properly wired.

6. Press the **100% Override** button on the Touch Screen interface. The **100% Override** button should turn green and all of the VFDs should ramp up to their respective high speed (60Hz factory default for Americas). The fans should stay at this speed for a factory set time of **30 minutes**. This time is adjustable as described in the Setup section. After the time interval expires, the drives should return to **48Hz or low speed**. The high speed and low speed frequencies are adjustable as described in the Setup section. One can also return the system to normal operation by pushing the **100% Override** button again before the timer expires.



7. The **% Savings** Icon on the Main page provides information on how much Fan Energy is saved by the system when running the fans at lower speed. It is calculated based on the actual Kilowatts measured from each Variable Frequency Drive controlling the fans. However it doesn't include the additional savings resulting from the lower CFM of Make-up air and HVAC air that require heating or cooling.



8. If the cooking appliances are connected to an Electric gas valve controlled by the EMSplus, the gas valve can be turned ON by pressing the **Gas Valve** icon for a couple of seconds. The icon will only show if the **Gas Valve Present** Option is turned ON on the Setup page.



9. Turn on the cooking appliance and allow them to reach idle temperature. If the fans are off, the fans should automatically be energized as the cooking appliance heats up. The low temperature set point should be set to approximately 10 degrees above kitchen room temperature. See the Exhaust Fan Setup section for further details.

The appliances running in idle mode should not make the EMSplus system operate at high speed. The fans should modulate during the cooking process. If the fans go to high speed while the cooking appliances are idling, the high temperature set point should be increased. See the Exhaust Fan Setup section for further details. If the fans never or rarely go to high speed while cooking is taking place, the high temperature set point should be decreased.

10. If the control contains the Self Cleaning option, an additional icon will be displayed on the Main screen. Push the icon to start the wash cycle. Water will be sprayed in the plenum and duct of the hood and surfactant will be injected at a set frequency. The wash cycle will stop when the wash timer expires or when the Wash icon is pressed again. **Make sure Hood filters remain in place during the wash cycle.**



Functionality

Individual Fan Control

1. This option is enabled by default from the factory. It can be disabled under **Setup** → **Fan Setup**.
2. This option makes the exhaust fans behave independently from each other. This means that they can be turned ON/OFF separately. This allows for greater energy savings since exhaust fans covering hoods that are not used can be shut down completely.
3. In systems that include 1 or 2 supply fans, one or several exhaust fans might have to be sped up or forced ON automatically by the system under some conditions in order to maintain the kitchen pressure balance while ensuring the supply fan is still delivering its minimum specified CFM. The system will decide which fan to force ON and at what speed to run it in order to minimize energy waste. Forcing will not occur if the fans are running in Preparation Time mode or in Wash mode since the Supply fans are maintained OFF.
4. In Preparation Time mode, all exhaust fans are also independently controlled. However if one exhaust fan goes out of Preparation Time mode, all other exhaust fans assigned to the same supply fan will also exit the preparation Time mode.

5. In some configurations with 3 or more exhaust fans, 2 exhaust fans might need to always run together, for example if those 2 fans are covering the same hood. To achieve this, the **Link Exh Fans** function under **Setup** → **Fan Setup** can be used. More details about this function can be found under the Setup Options section below. If 2 fans are linked, they will always come ON and OFF together, except if one of them is “Forced” On as described in item 3 above.
6. When individual fan control is selected, **Supply Dampers** should be used if a supply fan is feeding make-up air to more than 1 exhaust fan through Perforated Supply Plenums. The dampers should be installed in the main supply duct above each hood. This will ensure that make-up air is not supplied to a hood when it is not operating.

Preparation Time Mode

1. This option is enabled by default from the factory. It can be disabled under **Setup** → **Fan Setup**.
2. Preparation Time Mode is available for morning operation when appliances are off or when very light food preparation is performed. Dedicated make-up air will be locked out only allowing the use of transfer air during this mode. Exhaust fan(s) will run at low CFM while maintaining a balanced kitchen pressure.
3. Preparation Time mode can be initiated by different means:
 - By pressing the fan icon on the Touch Screen
 - Through the schedule when Fan Schedule is enabled.
 - Remotely through the building management system in BMS mode or through BACNET network if installed
 - If the “Room Thermostat” Option is enabled (factory default), when the duct temperature exceeds Room Temperature Measured + Prep Time Temp Offset (Factory Default: 5 °F).
4. The fans will go back to running in modulation mode if the Prep Off button is pressed on the Main screen, if the 100% Override button is pressed or if the temperature sensors in the duct measures a temperature above the Low Temp set point. Low Temp Set point is defined under Setup Options, items 3. a), b) and c). 
5. Note: The speed of the exhaust fan(s) in Preparation Time is calculated automatically and is equal to the speed that will produce the same amount of CFM than the Transfer CFM when the fans are running in full speed in normal operation.

Hood Lights

1. An EMSplus system can have between 1 and 8 light circuits. This allows the load on each circuit to stay below 1400W. It also allows separate control of each light circuit. For example, if the system contains multiple hoods, each hood can have its own light circuits.
2. Circuits for hood light can be controlled manually through the Lights Icon on the Touch Screen. But they will also be automatically turned ON or OFF when the Exhaust fan assigned to that circuit turns ON or OFF. However the manual command on the Touch Screen always takes priority. So if the lights come ON automatically, they can be turned OFF through the Touch Screen. And if they are turned ON through the Touch Screen, they cannot be automatically turned OFF.
3. If there are multiple hood light circuits, the assignment to exhaust fans can be configured under **Setup** → **Hood Lights Setup**.

Self-Cleaning function (Optional)

1. During the wash cycle, water will be sprayed in the plenum and duct and surfactant will be injected at a set frequency. The wash cycle will stop when the wash timer expires or when the Wash icon is pressed again. 
2. The wash timer is factory set to 3 minutes and is adjustable through the Wash Setup Page. The surfactant is injected for 1 second at the start of each minute of Wash. This setting is not adjustable.

3. **Hood filters MUST remain in place during the wash cycle.**
4. If the system is setup with multiple Wash Zones (maximum of 3) and the “Independent Wash Zones” option is disabled (factory default), once zone 1 wash is complete, the wash cycle will start over for Zone 2 after an adjustable delay (Delay between Zones, Factory Default: 15 min) and then for Zone 3 if applicable.
5. If the system is setup with multiple Wash Zones (maximum of 3) and the “Independent Wash Zones” option is enabled, each wash zone can be controlled independently. If the system also contains multiple exhaust fans, each fan needs to be assigned to a wash zone under **Setup** → **Wash Setup** → **Wash Zones Setup**.
6. The wash cycle can be initiated in multiple ways:
 - a. In manual mode, the Wash icon can be pressed on the Touch Screen Main page if the “Independent Wash Zones” option is disabled. If it is enabled, pressing the Wash icon will take you to the **Wash Control** page where either all zones can be washed or one zone can be washed at a time.
 - b. When Wash Schedule is enabled, the wash cycle will start according to the wash schedule programmed through the Schedule Screen. If the fans were running before the start of the wash cycle, the Exhaust fans will be forced to run at Wash frequency (factory default: 15 Hz) and the supply will be stopped during the wash cycle.
 - c. If the “Wash after Fans OFF” option is turned ON (factory default), the wash cycle will start when the exhaust fans turn OFF under certain conditions.
 - If “Independent Wash Zones” option is disabled, all exhaust fans will need to turn OFF. If “Independent Wash Zones” option is enabled, all exhaust fans assigned to a particular wash zone will need to turn off for that particular zone to start its wash cycle.
 - At least one of the exhaust fans assigned to a wash zone will need to have effectively run cumulatively for a period of time longer than the “Minimum Fan Runtime before Wash” value configured under **Setup** → **Wash Setup**. Preparation Time mode and Forced ON fan time do not count towards runtime. The runtime is reset to zero when the wash cycle for that particular wash zone is run.
 - The amount of time elapsed since the previous wash cycle for that particular zone is greater than the “Minimum Time before Subsequent Washes” value configured under **Setup** → **Wash Setup**. That elapsed time is reset to zero when the wash cycle for that particular wash zone is run.
 - d. If the Building Management System (BMS) option is turned ON, the BMS can remotely turn ON the wash cycle by turning the fans ON and OFF when the “Wash after Fans OFF” option is enabled.
7. If the surfactant level is too low, an alarm will be triggered on the Touch Screen Panel. If the wash cycle is initiated while this alarm is active, water will be sprayed but no surfactant will be injected. Refill Surfactant as soon as possible for best results.

Fan Proving Interlock (i.e. Loss of Load Interlock/Airflow Fault Interlock)

1. This function is only available if there is a supply fan in the system. This option is disabled by default from the factory. It can be enabled under **Setup** → **Fan Setup** → **Fan Proving Interlock**.
2. If this option is enabled, the load on all the exhaust and supply fans is constantly monitored. If the load for an exhaust fan or the load for a supply fan drops below the threshold calculated after calibration, all exhaust fans linked to the same supply fan, as well as that supply fan will shut down.
3. To reset the system after a loss of load fault, press the Airflow Fault Reset button on the Main page or on the Exhaust Fan Control page.
4. This function requires calibration, which can be performed through the **Fan Proving Interlock** page, described under the Setup Options section.



2nd Stage Cooling Interlock for RTU or Dedicated Make-Up Air with DX Coil

1. In order to save more energy, it is highly recommended that the second stage cooling of a Roof Top Unit or a dedicated make-up air unit be interlocked so it only runs when the supply fan is running at or near high speed. This interlock should also be combined with a cooling thermostat measuring outside temperature.
2. In the case of a dedicated make-up air unit which fan is controlled by the EMSplus, this interlock can be achieved by utilizing the relay on the Supply Fan VFD. By default this relay is configured to come ON when the fan is above a threshold frequency of 60 Hz. The contact on terminals 16-17 of the Supply VFD would then close. This contact should be wired in series with the cooling thermostat. The threshold frequency can be adjusted under **Setup → Fan Setup → Sup Fan Setup**.
3. If they are no dedicated supply fan on the EMSplus system and the make-up air is provided by a Roof Top unit (RTU), a dry contact is available inside the electrical panel between terminals Y2T and Y2C to interlock the second stage cooling of the RTU. The relay driving this contact is configured to come on when the ratio of Total Exhaust CFM over Total Design Exhaust CFM is above or equal to an adjustable threshold, set by default to 100%. This **Cooling Interlock Exhaust CFM Ratio** can be adjusted under **Setup → Fan Setup**.
4. In addition to the interlock, a 0-10VDC signal is provided on terminals 30 and 2 of the Exhaust VFD to modulate the position of the RTU outside air damper in order to provide the correct amount of outside air proportional to exhaust. Go to **Setup → Fan Setup → Exh Fan Setup** to set the **VFD 0-10VDC Output** option to **Total Exh CFM Ratio** on one of the exhaust VFD.

BACNET DDC Controls (Optional)

1. If the BACNET IP communication option has been ordered with the EMSplus controls, it can be used for monitoring and limited remote control of the system. A CAT-5 cable can be plugged in directly into the main controller Ethernet port (RJ-45).
2. A Building Management System can remotely turn fans and wash cycle ON and OFF. It can also monitor a lot of data. A list of all the available BACNET objects can be found in Annex A at the end of this manual.

CO Sensor (Optional)

If a CO Sensor is wired to the EMSplus and the CO sensor is triggered, all exhaust fans will be turned ON and will ramp up to their high speed. All supply fans will be turned OFF and the gas valve will be shut off.

Configuration

Security

With no user authentication, an operator can access the Main page, the Status pages, and the CORE page if present.

There are 3 levels of security associated with the Setup options.

1. To access most of the setup pages, the first level of security is required. This would be given to a user who would need to modify or optimize the operation of the system.
Username: **setup**, factory password: **change**.
2. To access the **Fire Options** page, the second level of security is required. This should only be given to a user who would configure the behavior of the system in case of fire. These options should NOT be changed one the fire inspection has been passed.
Username: **admin**, factory password: **casfire**.
3. To access the **Factory Setup** page, a third level of security is required. Only factory personnel should access this page since it contains options related to the physical hardware configuration of the system.

Passwords for those users can be changed under **Setup** → **Maintenance** → **Security**. Each user can change its own password but not the password of other users.

If a user is logged on to the system but remains inactive for more than 10 minutes, he will be automatically logged off. Also if a user wishes to logoff after performing setup changes to prevent anybody else from accessing the setup menus, the **User Logoff** button can be pressed on the Main page.



Setup Options

The EMSplus allows you to configure a whole range of options associated with the functionality of the system through its setup pages on the Touch Screen interface.

Starting from the Main page:

Press **Setup** on the top corner of the screen.

Press **Logon** when prompted. Enter Username and Password (see Security above).

1. The setup page will appear.

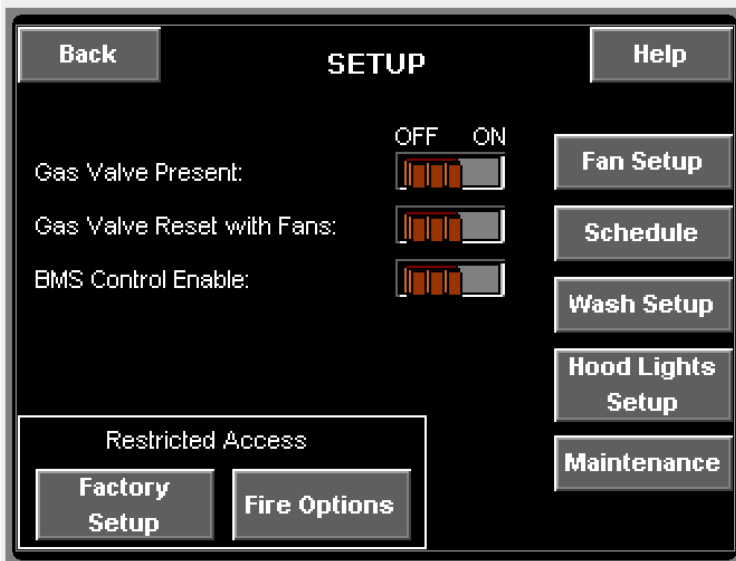

On the Setup page, you can Enable or Disable these options:

- a. **Gas Valve Present** and **Gas valve Reset with Fans**
- b. **BMS Control Enable**

- a. **Gas Valve** (Factory Default: ON) and **Gas Valve Reset with Fan** (Factory Default: OFF):

If the Gas Valve option is turned ON, an additional button is displayed on the main screen to allow the user to reset or re-energize an electric gas valve connected to the panel. The gas valve is de-energized at initial startup and when the Fire System is triggered. If the Gas Valve Reset with Fan option is also turned ON, the gas valve will also de-energize when the fans are turned off.

- b. **BMS Control Enable** (Factory Default: OFF):

If this option is turned ON, a Building Management System can turn the fans and the Wash Cycle ON and OFF remotely through a dry contact or through the BACNET Network if that feature was ordered with the EMSplus system. When in BMS mode, the fan icon and wash icon (if present) are disabled. The BMS dry contact has to be wired between terminal blocks BMS and HD. Refer to the electrical installation schematic for more details. Preparation Time and 100% Override button are still enabled in BMS mode.

The Fan Schedule is disabled when BMS Control is enabled.

If BMS Control is enabled and the Wash Schedule is enabled, the wash cycle cannot be controlled by the tags over the BACNET network.

Refer to Annex A at the end of this manual for a list of BACNET tags that can be used to control fans and wash cycle when BMS Control is enabled.

2. From the Setup Page, press **Fan Setup**.

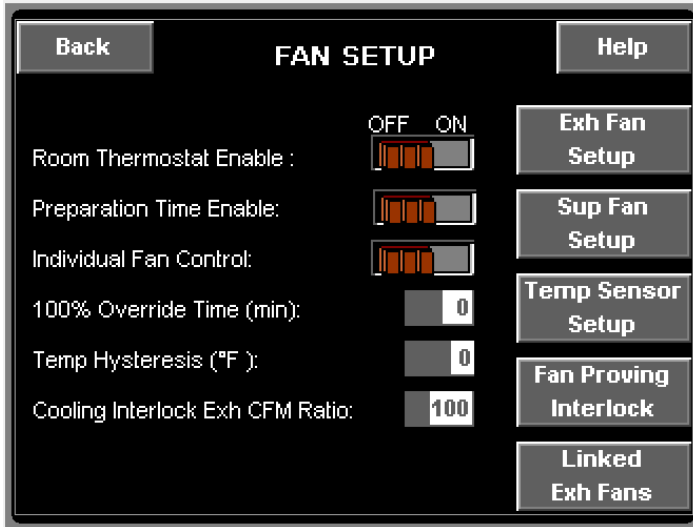

On the Fan Setup page you can enable or disable these options:

- a. **Room Thermostat Enable**
 - b. **Preparation Time Enable**
 - c. **Individual Fan Control**
- You can adjust the value of:
- d. **100% Override Time**
 - e. **Temperature Hysteresis**
 - f. **Cooling Interlock Exhaust CFM Ratio (%)**

- a. **Room Thermostat Enable** (Factory Default: ON):

A room temperature sensor is provided for field installation in the kitchen space. If the sensor is installed and wired and this option is ON, the fan(s) will start based on the temperature differential between the room and the exhaust air in the duct rather than fixed set-points. In that case, the Room Temp Offset and the Modulation Range have to be configured under the Exhaust Fan Setup page. If this option is OFF, the Low Temp and High Temp of the modulation range have to be configured under the Exhaust Fan Setup page. IT IS RECOMMENDED TO KEEP THIS OPTION ENABLED.

- b. **Preparation Time Enable** (Factory Default: ON): Refer to the Preparation Time Mode section under Functionality in this manual describing this function.

- c. **Individual Fan Control** (Factory Default: ON): This option is only available if there are multiple exhaust fans in the system. Refer to the Individual Fan Control section under Functionality of this manual for more details about this function.

- d. **100% Override Time** (Factory Default: 30 min):

This value is the time in minutes that the fans will run at 100% override when the 100% Override button is pressed. The minimum value is 1 min and the maximum value is 180 min.

- e. The **Temperature Hysteresis** (Factory Default: 2°F) is used to prevent the fans from cycling ON and OFF when the temperature in the duct is just around the low temperature setting. The fans will turn ON when the duct temperature exceeds the low temperature, but they will only turn off when the duct temperature goes below the low temperature minus the temperature hysteresis. For example, if Low Temperature is set to 85 °F and Temperature Hysteresis is set to 2 °F, the fans will turn ON at 85 °F and will turn OFF at 83 °F.

- f. **Cooling Interlock Exhaust CFM Ratio** (Factory Default: 100%): This option is only available when there are no supply fan in the system. Refer to **2nd Stage Cooling Interlock** under Functionality of this manual for more details about this option.

3. From the Fan Setup Page, press **Exh Fan Setup**.

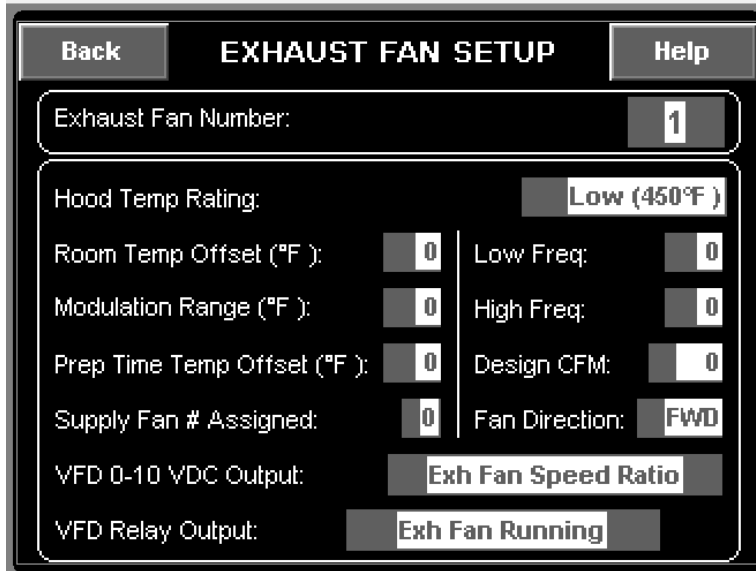

To select the next fan, press the exhaust fan number and press the RAISE button.

For each exhaust fan, you can set the:

- Hood Temperature Rating**
- Room Temperature Offset** and **Modulation Range** If Room Thermostat Enable is ON
- Low Temp** and **High Temp** If Room Thermostat Enable is OFF
- Low Frequency**
- High Frequency**
- Design CFM**
- Fan Direction**
- Preparation Time Temperature Offset**
- Supply Fan Number Assigned** to this Exhaust fan
- Function of the **VFD 0-10 VDC Output**.
- Function of the **VFD Relay Output**.

- a. **Hood Temp Rating:**

You can set it to Low for Hood rated at 450°F or High for hood rated at 600°F or 700°F. When this is changed, the temperature settings will be adjusted as shown below. The settings can also be manually changed based on application.

Hood Temp Rating	Room Thermostat Enable ON		Room Thermostat Enable OFF	
	Modulation Range	Low Temp	High Temp	
Low (450°F)	10 °F	85 °F	90 °F	
High (600°F or 700°F)	45 °F	85 °F	130 °F	

- b. **Room Temp Offset** (Factory Default: 10 °F) and **Modulation Range:**

These options are only available if Room Thermostat Enable is ON. With these values, the low temperature and the high temperature of the modulation range is dynamically calculated.

The low temperature is the value at which the fans will come on automatically and at which they are running on the Low Frequency value. Low temperature = Room temperature measured + Room Temp Offset

The high temperature is the value at which the fans are running at full speed or High Frequency. High temperature = Room temperature measured + Room Temp Offset + Modulation Range

- c. **Low Temp** and **High Temp:**

These options are only available if Room Thermostat Enable is OFF. The low temperature and the high temperature in those cases are static and will not vary with the room temperature measured.

- d. **Low Frequency** (Factory Default: 48 Hz):

The Low Frequency is the minimum frequency at which an exhaust fan will be running in modulation mode. The fan can still run slower in Wash mode or in Preparation Time. By default this value is set to 48 Hz which represents a minimum of 80% of full speed when High Frequency

is left at 60 Hz. 20% is the recommended modulation value to ensure capture and containment at the hood during cooking. Lowering this value is possible but should be carefully evaluated.

e. **High Frequency** (Factory Default: 60 Hz):

The High Frequency is the maximum frequency at which an exhaust fan will be running in modulation mode. This corresponds to the design CFM of the exhaust fan. This value can be adjusted during Test and Balance of the hood, if needed to adjust the amount of CFM exhausted at the hood when the adjustment is smaller than what can be achieved with a pulley change. The value can be increased to 65 Hz and lowered down to 40 Hz as long as it is 5 Hz above the Low frequency.

f. **Design CFM:**

This is the design CFM value specified for this exhaust fan. This value is internally matched to the High Frequency set for this fan and used to calculate the Supply fan frequency, as well as the Preparation Time Frequency. This value should be adjusted after Test and Balance has been performed on the hood.

Note: Changing this value will NOT automatically change the actual CFM exhausted by the fan. This is achieved by changing the **High Frequency**. This value is to report to the Controller what the design CFM is so it is used for internal calculation.

g. **Fan Direction** (Factory Default: FWD):

If the fan is running in the wrong direction at startup, the direction can be changed here without having to change the wiring of the 3-phase motor.

h. **Preparation Time Temperature Offset** (Factory Default: 5 °F):

This setting is only available when the Room Thermostat Enable option is ON. This value is used to put the exhaust fan in Preparation Time mode when duct temperature rises above room Temperature + Prep Time Temp Offset. Refer to the Preparation Time Mode section under Functionality in this manual describing this function.

i. **Supply Fan Number Assigned:**

This setting is only available if there are multiple exhaust fans on the system and the Individual Exhaust Fan option is ON. This value indicates the supply fan number that is providing Make-up Air to this Exhaust Fan.

j. **VFD 0-10 VDC Output** (Factory Default: Exhaust Fan Speed Ratio):

Each Variable Frequency Drive (VFD) in the EMSplus system can provide a 0-10 VDC analog output from its terminals 30 and 2. For each VFD, this output can be configured depending on the type of signal needed by the building management system or the equipment receiving it.

Three (3) types of signal are available for an exhaust VFD:

- Exhaust Fan Speed Ratio = Exh Fan Frequency / Exh Fan High Frequency
- Total Exh CFM Ratio = Total Operating Exh CFM / Total Design Exh CFM
- Total Transfer CFM Ratio = Total Operating Transfer CFM / Total Design Transfer CFM

The Exhaust Fan Speed ratio could be sent for example to a Building Management System monitoring the speed of the fans.

Total Exh CFM Ratio could be sent to a Roof Top Unit providing make-up air to the hood.

Finally Total Transfer CFM Ratio could be sent to a HVAC unit indicating how much transfer air is needed for the kitchen. This selection takes in consideration the Preparation Time Mode where the same amount of transfer air is used as when the fans are all running at maximum speed.

- k. **VFD Relay Output** (Factory Default: Exhaust Fan Running):
Each Variable Frequency Drive (VFD) has an internal output relay with dry contacts on terminals 16-17 of the VFD. For each VFD, this relay can be configured depending on the function required by the building management system or the equipment connected to it.
Two (2) functions are available for an exhaust VFD:
 - Exhaust Fan Running: Relay is ON (contacts 16-17 closed) when the fan is running.
 - Exh Fan Freq Above (Hz): Relay is ON when the fan is running above or at the frequency specified. By default, this frequency is set to 60 Hz.

4. From the Fan Setup Page, press **Sup Fan Setup**

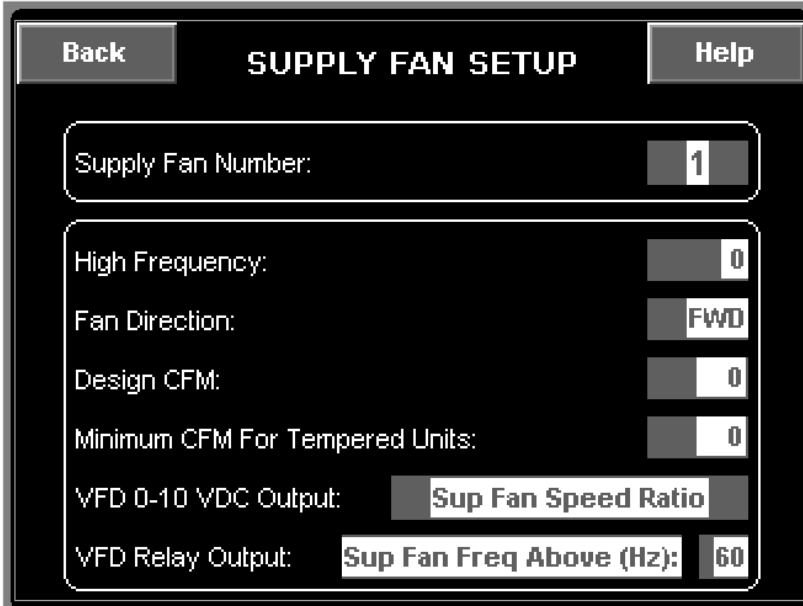

For each Supply fan, you can set the:

- a. **High Frequency**
- b. **Fan Direction**
- c. **Design CFM**
- d. **Minimum CFM for Tempered Units**
- e. **VFD 0-10 VDC Output**
- f. **VFD Output Relay**

To select the next fan, press the Supply Fan Number and press the RAISE button

For items a, b, c, please refer to the same options under Exhaust Fan Setup above for additional details.

- d. **Minimum CFM for Tempered Units:**
Tempered units specifications usually include a minimum CFM value. If entered, this value is used to calculate the minimum speed at which exhaust fans can run to maintain the kitchen pressure balance while ensuring the supply fan is still delivering its minimum specified CFM.
- e. **VFD 0-10 VDC Output** (Factory Default: Supply Fan Speed Ratio):
Refer to the same option under Exhaust Fan Setup above.
Three (3) types of signal are available for a supply VFD:
 - Supply Fan Speed Ratio = Sup Fan Frequency / Sup Fan High Frequency
 - Total Sup CFM Ratio = Total Operating Sup CFM / Total Design Sup CFM
 - Total Transfer CFM Ratio = Total Operating Transfer CFM / Total Design Transfer CFM
- f. **VFD Output Relay** (Factory Default: Sup Fan Freq Above 60 Hz):
Refer to the same option under Exhaust Fan Setup above.
NOTE: For **2nd Stage Cooling Interlock** for a Dedicated Make-Up Air Unit, described under functionality, make sure to set this option to **Sup Fan Freq Above (Hz)** and set the frequency desired at which the 2nd stage cooling of the dedicated make-up air unit should be enabled.

5. From the Fan Setup Page, press **Temp Sensor Setup**.

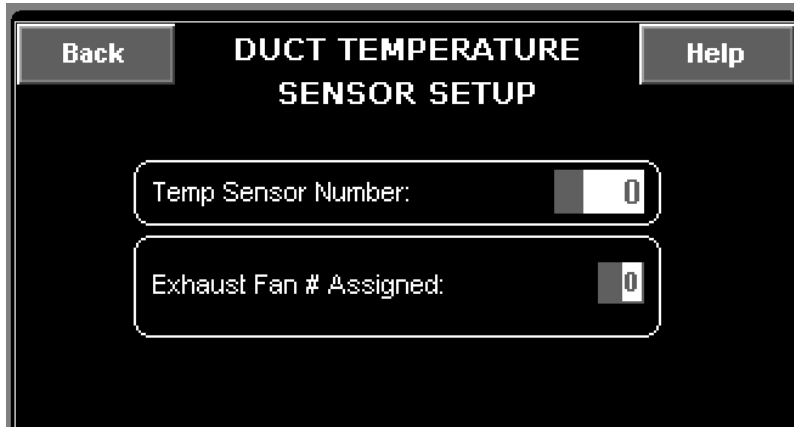

For each Duct Temperature Sensor, you can set the **Exhaust Fan Number** to which it is **assigned**.

To select the next temp sensor, press the Temp Sensor Number and press the RAISE button.

When there are multiple exhaust fans and multiple duct temperature sensors, each sensor needs to be assigned to an exhaust fan. The maximum reading of all the temperature sensors assigned to one exhaust fan will be used to calculate the modulation frequency of the fan.

6. From the Fan Setup Page, press **Fan Proving Interlock**.

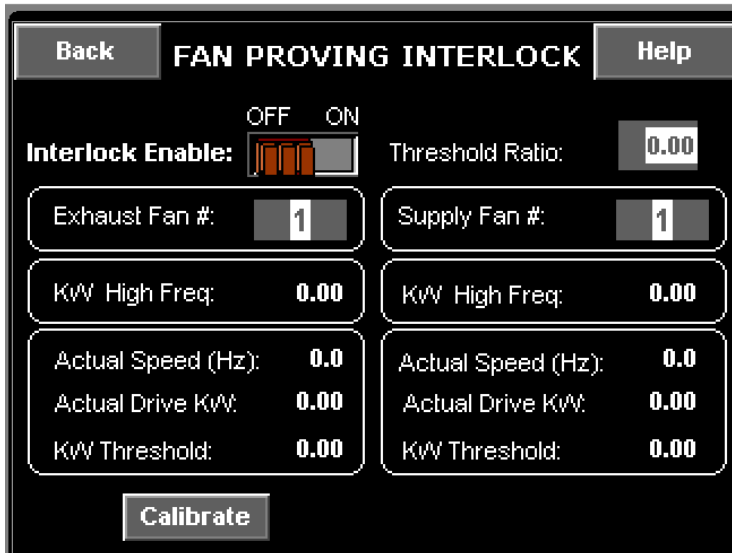

This screen is only available if there is a supply fan in the system.

On this page you can Enable or Disable the **Fan Proving Interlock**.

If enabled, calibration can be performed by pressing the **Calibrate** button. Calibration takes about 60 sec.

Finally you can adjust the **Threshold Ratio** between 0.50 and 1.00 (factory default 0.8). The greater the ratio, the tighter the limits will be for fault detection, which also means the greater likelihood of false positive.

After calibration, the kW consumed at high frequency is stored for each fan. For monitoring purposes, while the fans are running, you can view the values for the actual speed, the actual drive kW and the kW Threshold - which varies with speed - for each exhaust and supply fan.

7. From the Fan Setup Page, press **Linked Exhaust Fans**.

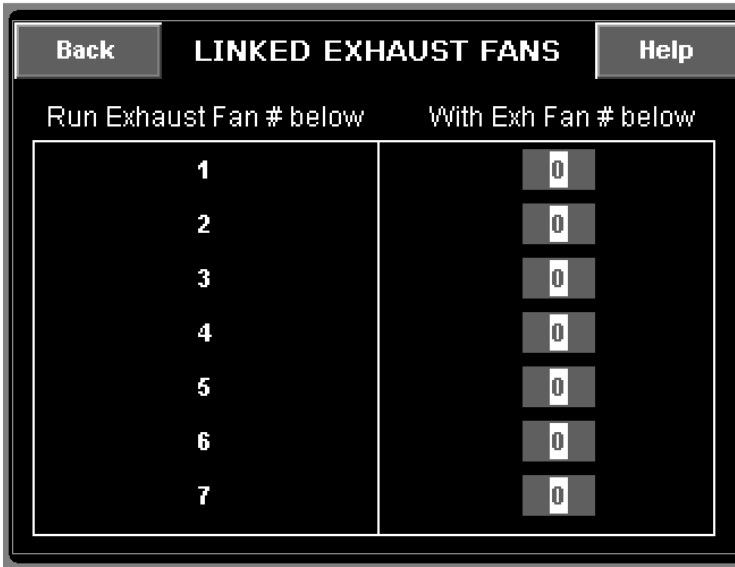

This screen is only available when the Individual Fan Control option is enabled and when there are more than 3 exhaust fans on the system.

Refer to the Individual Fan Control section of this manual under Functionality; item 5 for more details about when to use this page.

To link 2 exhaust fans, choose the number of one of the fans on the left and enter the number of the linked exhaust fan on the right.

8. From the Setup Page, press **Wash Setup** (if available).

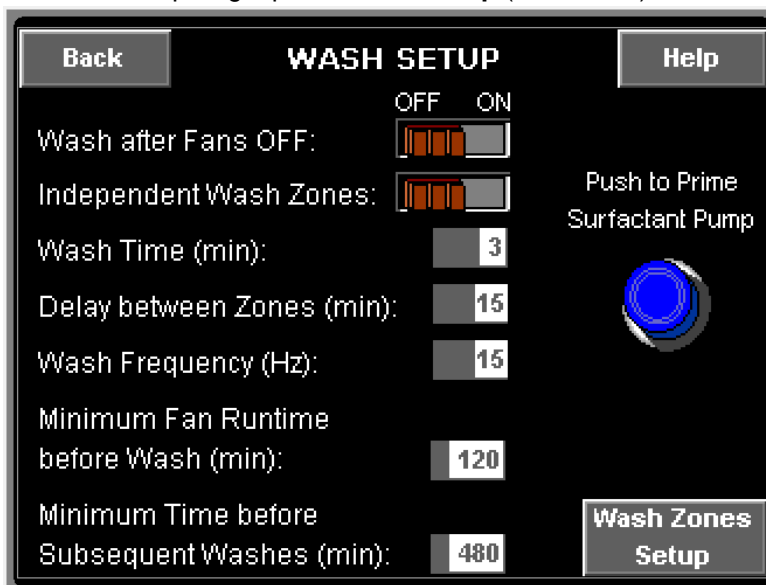

From this page, you can enable or disable these options:

- a) **Wash after Fans OFF**
- b) **Independent Wash Zones**

You can adjust the values of:

- c) **Wash Time**
- d) **Time Delay between Zones**
- e) **Wash frequency**
- f) **Minimum Fan Runtime before Wash**
- g) **Minimum Time before Subsequent Washes**

You can also **Prime the Surfactant Pump** by pressing the blue push-button.

- a. **Wash after Fans OFF** (Factory Default: ON): When this option is turned ON, the wash cycle will automatically start when the Fans are turned ON and then turned OFF. Also, this option disables the Wash Schedule.
- b. **Independent Wash Zones** (Factory Default: OFF): If this option is enabled, each wash zone can be controlled independently. Refer to the Self Cleaning Option section under Functionality for more details.
- c. **Wash Time (Min)** (Factory Default: 3 min): This value is setup in minutes with a maximum value of 30 minutes. This is the time the wash cycle will last for each wash zone.
- d. **Delay between Zones (Min)** (Factory Default: 15 min): This value is setup in minutes with a maximum value of 120 minutes. This is the time the system will wait in between washing two zones.

- e. **Wash Frequency** (Factory Default: 15 Hz): This value is the frequency at which all exhaust fans will run in wash mode. The Supply fan will be stopped during Wash.
- f. **Minimum Fan Runtime before Wash** (Factory Default: 240 min): This setting is only available if the Wash After Fans Off option is enabled. Its maximum value is 1440 minutes or 24 hours. Refer to the Self Cleaning Option section under Functionality for more details.
- g. **Minimum Time before Subsequent Washes** (Factory Default: 480 min): This setting is only available if the Wash After Fans Off option is enabled. Its maximum value is 1440 minutes or 24 hours. Refer to the Self Cleaning Option section under Functionality for more details.
- h. **Push to Prime Surfactant Pump** is used to prime the pump. Refer to the Self Cleaning Manual for more information about priming procedure.

9. From the Setup Page, press **Hood Lights Setup** (if available).



This screen is only available when there are two or more hood light circuits in the system.

Refer to the Hood Lights section of this manual under Functionality for more details

To associate a Light circuit to an exhaust fan, choose the number of the light circuit on the left and enter the number of the exhaust fan on the right.

10. From the Setup Page, press **System Options**

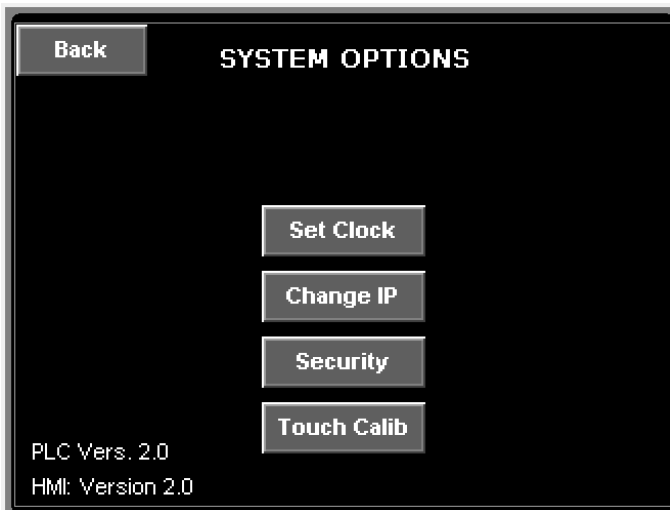

This page allows you to Change different system options.

Also, at the bottom left corner of his screen, the current version of software for your EMSplus is displayed.

11. From the System Options page, press **Set Clock**.



The system clock can be adjusted here.

Verify that date and time are correct. If they are not, press on the highlighted time. Press **Enter** to start editing the time. Once the time is correct, press **Enter** again. Then press **Save** to make it effective. Verify that the date and time at the bottom is updated.

12. From the System Options page, press **Change IP**:

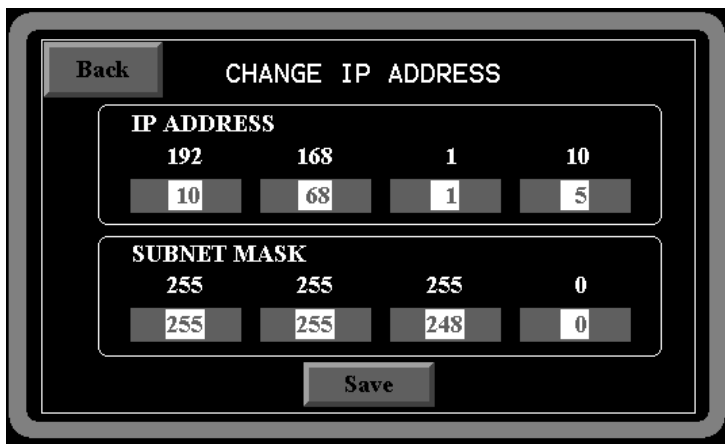

The controller has an Ethernet port that can be used to connect the EMSplus panel to a local Ethernet network. The Ethernet port can be used for maintenance purposes, for example to download a new revision of the software or troubleshoot a problem.

The controller comes preloaded with a factory default IP address of 192.168.1.10 and subnet mask of 255.255.255.0.

To change those values, press on the numbers with a grey background and enter the new IP Address and Subnet Mask. After pressing **Save**, a pop-up will ask the user to confirm. Press **Save** again to continue. Press **Cancel** otherwise.

Note: The Controller will reset in order to use the new values and communication will be lost for a few seconds. This will also cause a FALSE indication of a fire alarm. Acknowledge the alarm and close the alarm window. Fans, hood lights, wash cycle and gas valve will also be shutdown and will need to be manually turned on again.

13. From the System Options page, press **Security**:



From this screen, you can change the password of all 3 users: Admin, Setup and Factory.

To change a password for a particular user, you have to be logged in as that user. For example, if you are logged in as Admin, you can change the password of the Admin user but you cannot change the password of the Setup user.

14. From the System Options page, press **Touch Calib**:

This screen allows you to recalibrate the Touch response of the Touch Screen. This is only required if the Touch Screen is not reacting accurately to the touch. This page will display a set of instructions to calibrate the screen. It is required that you touch each of the squares shown on the display. It will then inform you as to the success or failure of the calibration. If the calibration failed, it is recommended that you run through it again.

15. From the Setup Page, press **Fire Options**.

This screen is Password protected and changes should not be made after passing an inspection. When prompted, press the logon button and enter Username and Password (username: Admin, see Security chapter above).

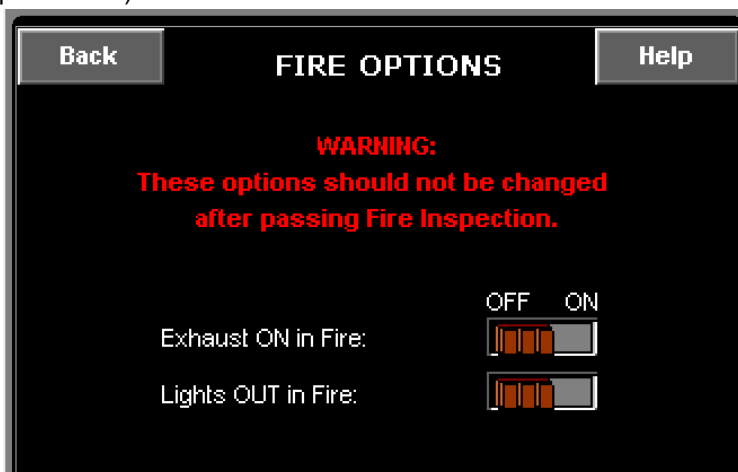

If the system comes with CORE Fire Protection, **Exhaust on in Fire** and **Lights Out in Fire** will automatically be forced ON.

If the system doesn't have CORE, You can set the **Exhaust ON in Fire** option and **Lights Out in Fire** option.

- a. **Exhaust On in Fire** (Factory Default: ON): When this option is turned ON, the exhaust fans will be turned ON in a fire condition. If the option is turned OFF, the exhaust fans will stay in whatever state they were before the fire condition. The supply fans will always be turned OFF in a fire condition.
- b. **Lights Out In Fire** (Factory Default: ON): When this option is turned ON, the hood lights will be turned OFF in a Fire condition. If the option is turned OFF, the hood lights will stay in whatever state they were before the fire condition.

16. From the Setup Page, press **Factory Setup**.

This screen is password protected (user: Factory, See Security Setup above) and normally only accessed by the factory since all the settings under this screen are directly related to the hardware configuration of the system. Only access this page if instructed by the manufacturer.



You can set:

- a. The total **Number of Exhaust fans**
- b. The total **Number of Supply fans**
- c. The total **Number of Temp Sensors**
- d. The total **Number of Hood Light Circuits**
- e. **CORE Fire Protection**
- f. **Self-Cleaning Enable**
- g. The **Number of Wash Zones**

- e. **CORE Fire Protection:** When this option is ON, the **Self Cleaning** option is automatically enabled and the **Number of Wash Zones** is forced to 1.

An additional screen will be available from the main page to view status and error messages from the CORE System.

- f. If **CORE Fire Protection** is OFF, the **Self-Cleaning Enable** option can be ON or OFF.

- g. **Number of Wash Zones:** A maximum of 3 wash zones can be set. One water solenoid is required for each Wash Zone. When the system has CORE, only 1 wash zone is available.

Scheduling

The EMSplus panel provides the ability to program when the fans and the wash cycle should operate on a 7-day, 24-hour schedule.

From the Setup Page, Press **Schedule**.

You can individually enable or disable the Fan Schedule and the Wash Schedule (if present). If disabled, the fans and/or wash cycle are controlled by the user through the buttons on the main page of the Touch Screen. If enabled, the Fans and/or wash cycle are controlled by the schedule configured in the system.

Fan Schedule is also disabled if the BMS Enable option is ON under the Setup Page.

Wash Schedule is also disabled if the Wash After Fans Off option is ON under the Wash Setup page.

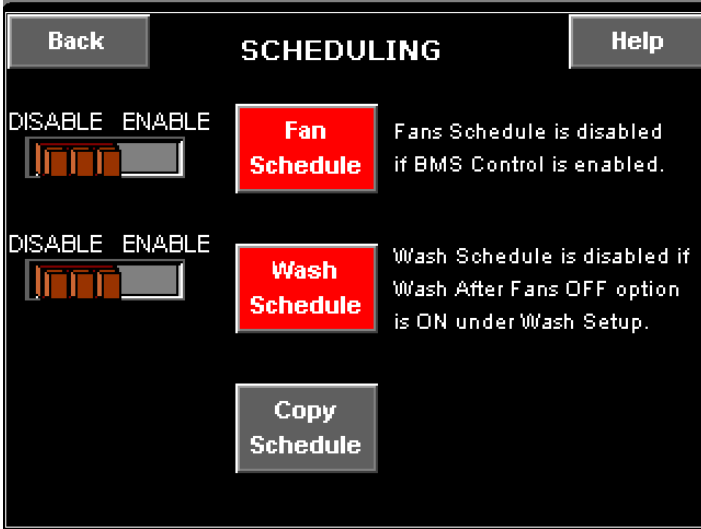

1. **Fan Schedule:** For each day of the week, 8 programs are available per exhaust fan if the Individual Fan Control option is ON, or 8 programs for all fans together if the Individual Fan Control option is OFF. Each program can be enabled individually. Push on the items with a gray background to modify their value. Select the Weekday, Exhaust Fan number (if available) and Program number. Press **Push to Enable** to activate the program. You can then edit the Time and Fans State. If a program is not to be used, you can disable it by pressing the **Push to Disable** button. The Fans state can be set to ON or OFF for each program.

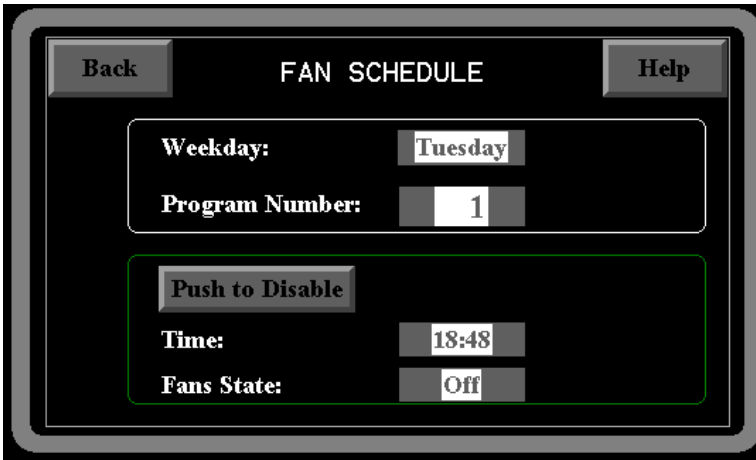

For example, if on Tuesdays, fans need to run from 8:00 am to 1:00 pm and then from 2:00 pm to 8:00 pm, the following programs would be used.

Tuesday	Program 1	Enabled	8:00 am	Fans On
Tuesday	Program 2	Enabled	1:00 pm	Fans Off
Tuesday	Program 3	Enabled	2:00 pm	Fans On
Tuesday	Program 4	Enabled	8:00 pm	Fans Off
Tuesday	Program 5	Disabled		

- Wash Schedule:** For each day of the week, 3 programs per wash zone are available if the Independent Wash Zone option is ON, or 3 programs for all wash zones together if the Independent Wash Zone option is OFF. Each program can be enabled individually. Push on the items with a gray background to modify their value. Select the Weekday, Wash Zone number (if available) and Program number. Press **Push to Enable** to activate the program. You can then edit the Time. If a program is not to be used, you can disable it by pressing the **Push to Disable** button. The wash cycle will start at the time scheduled and run as described in the Self Cleaning section of this document. Note that if the fans are programmed to run during the same time, the Fan Schedule will be interrupted and started back again at the end of the wash cycle.

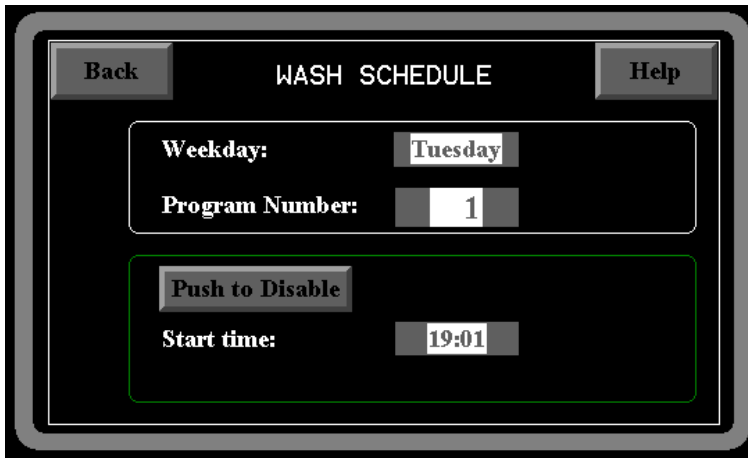

For example, if on Tuesdays, Wash cycle needs to run at 1:30 pm and then at 9:00 pm, the following programs would be used.

Tuesday	Program 1	Enabled	1:30 pm
Tuesday	Program 2	Enabled	9:00 pm
Tuesday	Program 3	Disabled	

- Copy Schedule Function:** This allows the user to copy all 10 programs for both Fan schedule and Wash schedule from one weekday to the other.

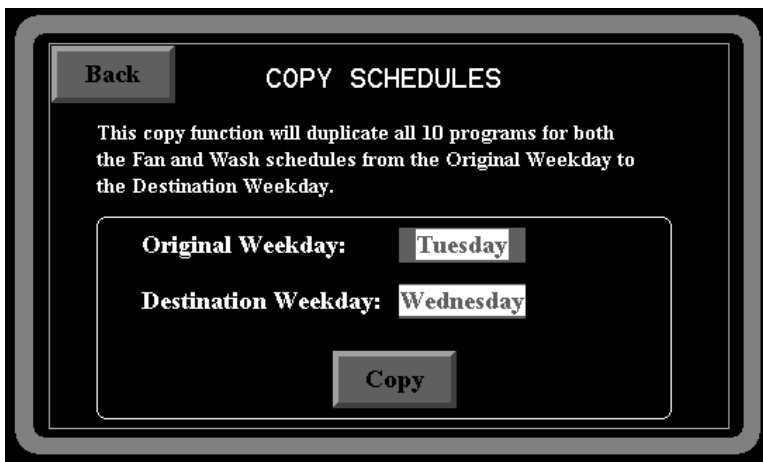

Select the original and destination weekday and press **Copy**. A pop-up will ask the user to confirm. Press **Copy** again to continue. Press **Cancel** otherwise.

Status and Diagnostics

Alarms

When an Alarm is triggered, an audible alarm and a visual indication are generated on the Touch Screen panel. The Audible Alarm can be silenced by pushing the Mute button. Some Alarms are automatically acknowledged when the condition is resolved and some require a manual acknowledgement on the screen. For example, a low surfactant alarm will automatically disappear when the surfactant is refilled. However, a Fire Condition Alarm will remain on the screen until the condition is resolved and the user presses the Acknowledge button on the alarm screen.

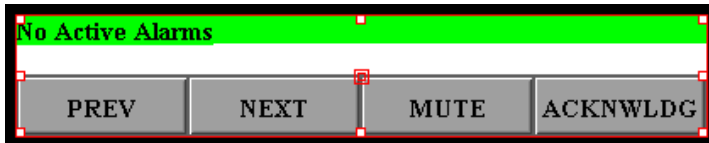

Status Page

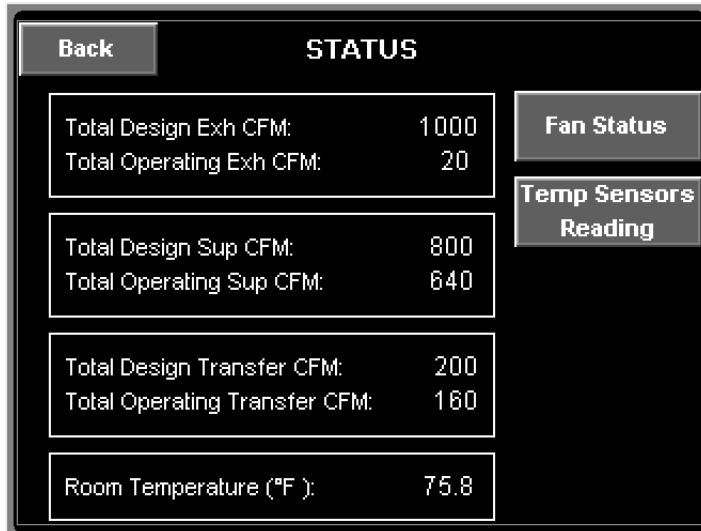

The Status Screen allows the user to monitor the total CFM of the system during operation, compared to the design CFM when the fans run at full speed. It also shows the Room Temperature when the Room Thermostat option is enabled.

Fan Status Page

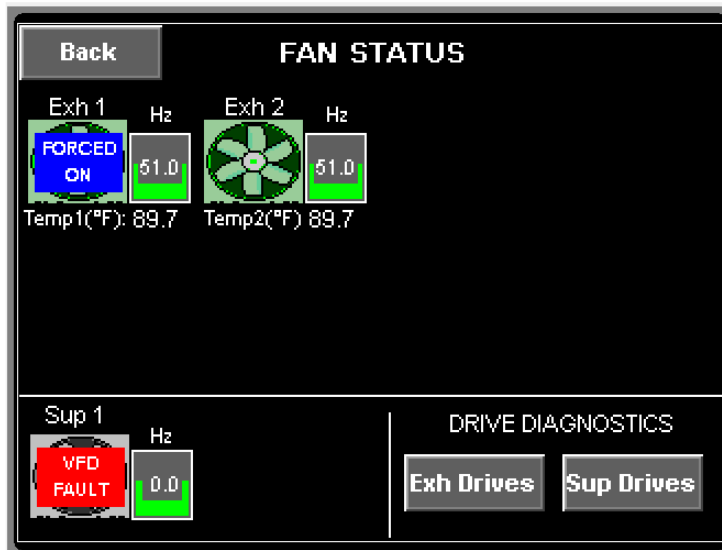

The Fan Status Screen allows the user to monitor the speed of each individual fan, as well as the duct temperature for each exhaust fan (Maximum temperature of all duct temperature sensors assigned to an exhaust fan).

One can also access the Drive Diagnostics for the Exhaust and Supply Drives.

It also can show the status of a fan. The status can be one of the following:

- VFD Fault: The VFD associated to that fan is faulted. Go to the Drive Diagnostic to get a detailed description of the fault.
- Airflow Fault: An Airflow proving fault on that fan has been detected. Refer to the Fan Proving Interlock section under Functionality for additional information.
- FORCED ON: The fan has been forced ON to maintain the kitchen pressure balance while ensuring the supply fan is still delivering its minimum specified CFM. Refer to the Individual Fan Control section under Functionality for additional information.
- SPED UP: The speed of the fan has been increased to maintain the kitchen pressure balance while ensuring the supply fan is still delivering its minimum specified CFM.
- PREP TIME: The fan is running in Preparation Time Mode. Refer to the Preparation Time Mode section under Functionality for additional information.
- WASH: The fan is running at the Wash frequency while the hood is being washed.
- DUCT STAT: The fan is running because its duct temperature is above the Lower Temperature setting for this fan.

Drive Diagnostics

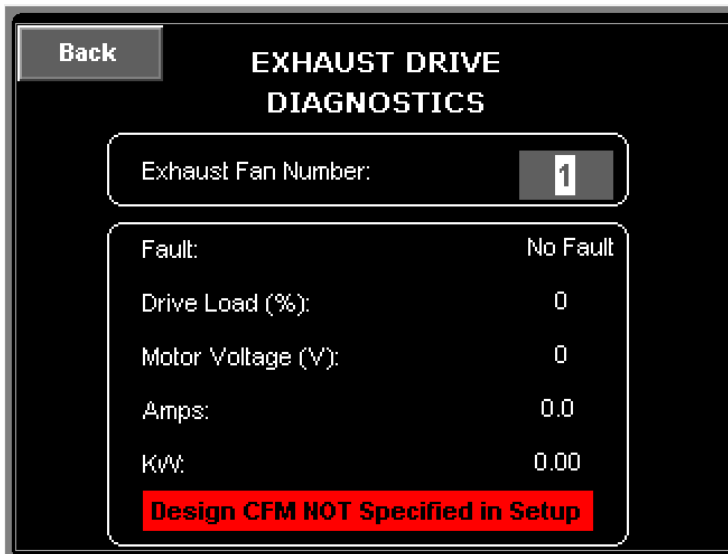

On either the Exhaust Drive Diagnostics or the Supply Drive Diagnostics pages, for each drive, you can view:

- a. If there is fault on the drive.
- b. The drive load percentage (ratio of actual motor current over drive rated output amps).
- c. The motor voltage
- d. The motor current in Amps
- e. The KW consumed

To select the next fan, press the fan number and press the RAISE button.

Temperature Sensors Reading Page

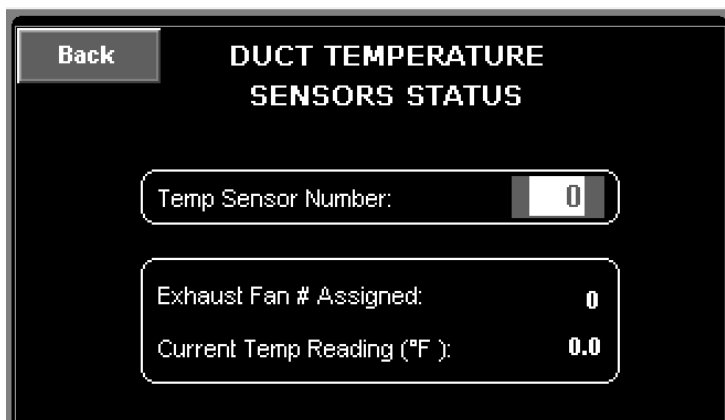

The temperature reading for each individual duct sensor is displayed on this page.

The Exhaust Fan Number to which the duct sensor is assigned is also displayed here.

To select the next fan, press the fan number and press the RAISE button.

CORE

If the EMSplus is combined with a CORE Fire Systems, an additional screen is available through the Main Page.

The screenshot shows a 'CORE STATUS' screen with a 'Back' button in the top left. The screen displays two voltage readings: 'CORE Battery Voltage: 27.50' and 'CORE Power Supply Voltage: 27.50'. Below these is a green bar with the text 'System Armed and Supervized'. Underneath is a list of 15 numbered items, each labeled 'System Armed and Supervized'. Three red arrows point from callout boxes to specific elements: one to the 'CORE Power Supply Voltage' value, one to the green status bar, and one to item 11 in the list.

Back	CORE STATUS
CORE Battery Voltage:	27.50
CORE Power Supply Voltage:	27.50
System Armed and Supervized	
1 System Armed and Supervized	9 System Armed and Supervized
2 System Armed and Supervized	10 System Armed and Supervized
3 System Armed and Supervized	11 System Armed and Supervized
4 System Armed and Supervized	12 System Armed and Supervized
5 System Armed and Supervized	13 System Armed and Supervized
6 System Armed and Supervized	14 System Armed and Supervized
7 System Armed and Supervized	15 System Armed and Supervized
8 System Armed and Supervized	

The CORE screen displays the CORE battery voltage as well as the CORE Power Supply voltage.

CORE Status Message from Hood CORE system directly connected to EMSplus.

CORE Status Messages from other CORE systems connected to the CORE Interlock network.

Component Description

Variable Frequency Drive

Variable frequency drives change the speed of 3 phase motors by changing the frequency signal sent to the motor. There is one variable frequency drive for each fan in this system. On the cover of each fan, a communication card is attached to the drive in order to send and receive messages from the main controller. The communication card is connected to other communication cards and to the main controller through a shielded 2-wire cable with a drain wire. The cable will be provided from the factory when the drives need to be connected in the field.



Variable Frequency Drive Parameters

Variable frequency drive parameters can be changed with the buttons on the face of the drive. Only parameters P107 (Line voltage Selection) and P108 (Motor Overload) should be adjusted in the field if needed. All other settings can be adjusted through the Touch Screen interface.

P107 is set to 0 (Low) if motor voltage is 120 VAC, 208 VAC or 400 VAC. P107 is set to 1 (High) if motor voltage is 230 VAC, 480 VAC or 575 VAC.

P108 is calculated as $\text{Motor FLA} \times 100 / \text{Drive Output Rating}$ (available in the VFD cross reference table under the Electrical Installation chapter above).

To enter the PROGRAM mode to access the parameters:

1. Press the Mode (M) button. This will activate the password prompt (PASS).
2. Use the Up and Down buttons to scroll to the password value (the factory default password is "0225") and press the Mode (M) button. Once the correct password is entered, the display will read "P100", which indicates that the PROGRAM mode has been accessed at the beginning of the parameter menu.
3. Use the Up and Down buttons to scroll to the desired parameter number.
4. Once the desired parameter is found, press the Mode (M) button to display the present parameter setting. The parameter value will begin blinking, indicating that the present parameter setting is being displayed. The value of the parameter can be changed by using the Up and Down buttons.
5. Pressing the Mode (M) button will store the new setting and also exit the PROGRAM mode. To change another parameter, press the Mode (M) button again to re-enter the PROGRAM mode. If the Mode button is pressed within 1 minute of exiting the PROGRAM mode, the password is not required to access the parameters. After one minute, the password must be re-entered in order to access the parameters again.

P500 parameter provides a history of the last 8 faults on the drive. It can be accessed without getting into PROGRAM mode.

Temperature Sensor

The temperature sensor is a digital RTD (Resistance Temperature Detector). The sensor gives constant feedback to the controller. One sensor is installed in every riser. The maximum value of all sensors associated with one exhaust fan is used to modulate that fan.

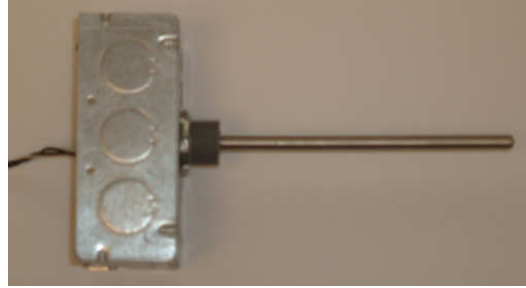

Room Temperature Sensor

The Room temperature sensor is a digital RTD (Resistance Temperature Detector). The sensor provides constant room temperature to the controller. It should be installed on a wall somewhere in the space but not directly under the hood or close to an appliance so that the reading is not affected by it.



Programmable Logic Controller (PLC)

The PLC is the main brain of the system. It receives all the digital and analog inputs and delivers the digital outputs and sends out messages to the drives.



Touch Screen Interface

The Touch Screen Interface is rated NEMA 4 in order to withstand grease and water when installed on the face of the hood or utility cabinet. The Touch Screen Interface is connected to the PLC through a CAT-5 cable. If the Touch Screen interface is installed on the face of the hood, a high temperature CAT-5 Cable should be used.



ANNEX A: BACNET Objects

Here a list of all the objects available over the BACNET IP Network. The BACNET type of all objects is ANALOG_VALUE.

OBJECT NAME	ID	CONTROL/ MONITORING	UNIT	DESCRIPTION
BACNET_Temp1_Sens_Reading	AV0	MONITORING	Tenth of Fahrenheit	Temperature duct Sensor #1
BACNET_Temp2_Sens_Reading	AV1	MONITORING	Tenth of Fahrenheit	Temperature duct Sensor #2
BACNET_Temp3_Sens_Reading	AV2	MONITORING	Tenth of Fahrenheit	Temperature duct Sensor #3
BACNET_Temp4_Sens_Reading	AV3	MONITORING	Tenth of Fahrenheit	Temperature duct Sensor #4
BACNET_Temp5_Sens_Reading	AV4	MONITORING	Tenth of Fahrenheit	Temperature duct Sensor #5
BACNET_Temp6_Sens_Reading	AV5	MONITORING	Tenth of Fahrenheit	Temperature duct Sensor #6
BACNET_Temp7_Sens_Reading	AV6	MONITORING	Tenth of Fahrenheit	Temperature duct Sensor #7
BACNET_Temp8_Sens_Reading	AV7	MONITORING	Tenth of Fahrenheit	Temperature duct Sensor #8
BACNET_Temp9_Sens_Reading	AV8	MONITORING	Tenth of Fahrenheit	Temperature duct Sensor #9
BACNET_Temp10_Sens_Reading	AV9	MONITORING	Tenth of Fahrenheit	Temperature duct Sensor #10
BACNET_Temp11_Sens_Reading	AV10	MONITORING	Tenth of Fahrenheit	Temperature duct Sensor #11
BACNET_Temp12_Sens_Reading	AV11	MONITORING	Tenth of Fahrenheit	Temperature duct Sensor #12
BACNET_Temp13_Sens_Reading	AV12	MONITORING	Tenth of Fahrenheit	Temperature duct Sensor #13
BACNET_Temp14_Sens_Reading	AV13	MONITORING	Tenth of Fahrenheit	Temperature duct Sensor #14
BACNET_Temp15_Sens_Reading	AV14	MONITORING	Tenth of Fahrenheit	Temperature duct Sensor #15
BACNET_Temp16_Sens_Reading	AV15	MONITORING	Tenth of Fahrenheit	Temperature duct Sensor #16
BACNET_Temp17_Sens_Reading	AV16	MONITORING	Tenth of Fahrenheit	Temperature duct Sensor #17
BACNET_Temp18_Sens_Reading	AV17	MONITORING	Tenth of Fahrenheit	Temperature duct Sensor #18
BACNET_Temp19_Sens_Reading	AV18	MONITORING	Tenth of Fahrenheit	Temperature duct Sensor #19
BACNET_Temp20_Sens_Reading	AV19	MONITORING	Tenth of Fahrenheit	Temperature duct Sensor #20
BACNET_Temp21_Sens_Reading	AV20	MONITORING	Tenth of Fahrenheit	Temperature duct Sensor #21
BACNET_Temp22_Sens_Reading	AV21	MONITORING	Tenth of Fahrenheit	Temperature duct Sensor #22
BACNET_Temp23_Sens_Reading	AV22	MONITORING	Tenth of Fahrenheit	Temperature duct Sensor #23
BACNET_Temp24_Sens_Reading	AV23	MONITORING	Tenth of Fahrenheit	Temperature duct Sensor #24
BACNET_Temp25_Sens_Reading	AV24	MONITORING	Tenth of Fahrenheit	Temperature duct Sensor #25
BACNET_Temp26_Sens_Reading	AV25	MONITORING	Tenth of Fahrenheit	Temperature duct Sensor #26

BACNET_Temp27_Sens_Reading	AV26	MONITORING	Tenth of Fahrenheit	Temperature duct Sensor #27
BACNET_Temp28_Sens_Reading	AV27	MONITORING	Tenth of Fahrenheit	Temperature duct Sensor #28
BACNET_Temp29_Sens_Reading	AV28	MONITORING	Tenth of Fahrenheit	Temperature duct Sensor #29
BACNET_Temp30_Sens_Reading	AV29	MONITORING	Tenth of Fahrenheit	Temperature duct Sensor #30
BACNET_Room_Temp_Reading	AV30	MONITORING	Tenth of Fahrenheit	Temperature Room Sensor
BACNET_Exh1_Temp_Max_Reading	AV31	MONITORING	Tenth of Fahrenheit	Max Temperature from all duct sensors on Exhaust #1
BACNET_Exh2_Temp_Max_Reading	AV32	MONITORING	Tenth of Fahrenheit	Max Temperature from all duct sensors on Exhaust #2
BACNET_Exh3_Temp_Max_Reading	AV33	MONITORING	Tenth of Fahrenheit	Max Temperature from all duct sensors on Exhaust #3
BACNET_Exh4_Temp_Max_Reading	AV34	MONITORING	Tenth of Fahrenheit	Max Temperature from all duct sensors on Exhaust #4
BACNET_Exh5_Temp_Max_Reading	AV35	MONITORING	Tenth of Fahrenheit	Max Temperature from all duct sensors on Exhaust #5
BACNET_Exh6_Temp_Max_Reading	AV36	MONITORING	Tenth of Fahrenheit	Max Temperature from all duct sensors on Exhaust #6
BACNET_Exh7_Temp_Max_Reading	AV37	MONITORING	Tenth of Fahrenheit	Max Temperature from all duct sensors on Exhaust #7
BACNET_Exh8_Temp_Max_Reading	AV38	MONITORING	Tenth of Fahrenheit	Max Temperature from all duct sensors on Exhaust #8
BACNET_Exh1_Fans_Speed	AV39	MONITORING	Tenth of Hertz	Speed of Exhaust fan #1
BACNET_Exh2_Fans_Speed	AV40	MONITORING	Tenth of Hertz	Speed of Exhaust fan #2
BACNET_Exh3_Fans_Speed	AV41	MONITORING	Tenth of Hertz	Speed of Exhaust fan #3
BACNET_Exh4_Fans_Speed	AV42	MONITORING	Tenth of Hertz	Speed of Exhaust fan #4
BACNET_Exh5_Fans_Speed	AV43	MONITORING	Tenth of Hertz	Speed of Exhaust fan #5
BACNET_Exh6_Fans_Speed	AV44	MONITORING	Tenth of Hertz	Speed of Exhaust fan #6
BACNET_Exh7_Fans_Speed	AV45	MONITORING	Tenth of Hertz	Speed of Exhaust fan #7
BACNET_Exh8_Fans_Speed	AV46	MONITORING	Tenth of Hertz	Speed of Exhaust fan #8
BACNET_Sup1_Fans_Speed	AV47	MONITORING	Tenth of Hertz	Speed of Supply fan #1
BACNET_Sup2_Fans_Speed	AV48	MONITORING	Tenth of Hertz	Speed of Supply fan #2
BACNET_Exh1_Drive_Amps	AV49	MONITORING	Tenth of Amps	Amps of Exhaust fan #1
BACNET_Exh2_Drive_Amps	AV50	MONITORING	Tenth of Amps	Amps of Exhaust fan #2
BACNET_Exh3_Drive_Amps	AV51	MONITORING	Tenth of Amps	Amps of Exhaust fan #3
BACNET_Exh4_Drive_Amps	AV52	MONITORING	Tenth of Amps	Amps of Exhaust fan #4
BACNET_Exh5_Drive_Amps	AV53	MONITORING	Tenth of Amps	Amps of Exhaust fan #5
BACNET_Exh6_Drive_Amps	AV54	MONITORING	Tenth of Amps	Amps of Exhaust fan #6
BACNET_Exh7_Drive_Amps	AV55	MONITORING	Tenth of Amps	Amps of Exhaust fan #7
BACNET_Exh8_Drive_Amps	AV56	MONITORING	Tenth of Amps	Amps of Exhaust fan #8

BACNET_Sup1_Drive_Amps	AV57	MONITORING	Tenth of Amps	Amps of Supply fan #1
BACNET_Sup2_Drive_Amps	AV58	MONITORING	Tenth of Amps	Amps of Supply fan #2
BACNET_Exh1_Drive_KW	AV59	MONITORING	100th of Kilowatts	KW of Exhaust fan #1
BACNET_Exh2_Drive_KW	AV60	MONITORING	100th of Kilowatts	KW of Exhaust fan #2
BACNET_Exh3_Drive_KW	AV61	MONITORING	100th of Kilowatts	KW of Exhaust fan #3
BACNET_Exh4_Drive_KW	AV62	MONITORING	100th of Kilowatts	KW of Exhaust fan #4
BACNET_Exh5_Drive_KW	AV63	MONITORING	100th of Kilowatts	KW of Exhaust fan #5
BACNET_Exh6_Drive_KW	AV64	MONITORING	100th of Kilowatts	KW of Exhaust fan #6
BACNET_Exh7_Drive_KW	AV65	MONITORING	100th of Kilowatts	KW of Exhaust fan #7
BACNET_Exh8_Drive_KW	AV66	MONITORING	100th of Kilowatts	KW of Exhaust fan #8
BACNET_Sup1_Drive_KW	AV67	MONITORING	100th of Kilowatts	KW of Supply fan #1
BACNET_Sup2_Drive_KW	AV68	MONITORING	100th of Kilowatts	KW of Supply fan #2
BACNET_Exh1_Drive_Fault_Status	AV69	MONITORING	See list below	Fault on Exhaust VFD #1
BACNET_Exh2_Drive_Fault_Status	AV70	MONITORING	See list below	Fault on Exhaust VFD #2
BACNET_Exh3_Drive_Fault_Status	AV71	MONITORING	See list below	Fault on Exhaust VFD #3
BACNET_Exh4_Drive_Fault_Status	AV72	MONITORING	See list below	Fault on Exhaust VFD #4
BACNET_Exh5_Drive_Fault_Status	AV73	MONITORING	See list below	Fault on Exhaust VFD #5
BACNET_Exh6_Drive_Fault_Status	AV74	MONITORING	See list below	Fault on Exhaust VFD #6
BACNET_Exh7_Drive_Fault_Status	AV75	MONITORING	See list below	Fault on Exhaust VFD #7
BACNET_Exh8_Drive_Fault_Status	AV76	MONITORING	See list below	Fault on Exhaust VFD #8
BACNET_Sup1_Drive_Fault_Status	AV77	MONITORING	See list below	Fault on Supply VFD #1
BACNET_Sup2_Drive_Fault_Status	AV78	MONITORING	See list below	Fault on Supply VFD #2
BACNET_Exh1_Load_Fault	AV79	MONITORING	0: No Fault, 1: Load Fault	Load (Proving) fault on Exhaust #1
BACNET_Exh2_Load_Fault	AV80	MONITORING	0: No Fault, 1: Load Fault	Load (Proving) fault on Exhaust #2
BACNET_Exh3_Load_Fault	AV81	MONITORING	0: No Fault, 1: Load Fault	Load (Proving) fault on Exhaust #3
BACNET_Exh4_Load_Fault	AV82	MONITORING	0: No Fault, 1: Load Fault	Load (Proving) fault on Exhaust #4
BACNET_Exh5_Load_Fault	AV83	MONITORING	0: No Fault, 1: Load Fault	Load (Proving) fault on Exhaust #5
BACNET_Exh6_Load_Fault	AV84	MONITORING	0: No Fault, 1: Load Fault	Load (Proving) fault on Exhaust #6
BACNET_Exh7_Load_Fault	AV85	MONITORING	0: No Fault, 1: Load Fault	Load (Proving) fault on Exhaust #7
BACNET_Exh8_Load_Fault	AV86	MONITORING	0: No Fault, 1: Load Fault	Load (Proving) fault on Exhaust #8
BACNET_Sup1_Load_Fault	AV87	MONITORING	0: No Fault, 1: Load Fault	Load (Proving) fault on Exhaust #9

BACNET_Sup2_Load_Fault	AV88	MONITORING	0: No Fault, 1: Load Fault	Load (Proving) fault on Exhaust #10
BACNET_Surfactant_Level_Low	AV89	MONITORING	0: No fault, 1: Low Surfactant Fault	Surfactant level low for Self Cleaning system
BACNET_PCU_Pressure_SW	AV90	MONITORING	0: No fault, 1: PCU Pressure fault	Pollution Control Unit Pressure Fault if PCU in the system
BACNET_Fire_Alarm	AV91	MONITORING	0: No fault, 1: Fire Alarm	Fire Alarm on hood system
BACNET_CO_Sensor	AV92	MONITORING	0: No fault, 1: CO Alarm	CO Sensor alarm
BACNET_Exh1_Fan_Start_Cmd	AV93	CONTROL	0: Stop, 1: Run	Fan control command for Exhaust #1
BACNET_Exh2_Fan_Start_Cmd	AV94	CONTROL	0: Stop, 1: Run	Fan control command for Exhaust #2
BACNET_Exh3_Fan_Start_Cmd	AV95	CONTROL	0: Stop, 1: Run	Fan control command for Exhaust #3
BACNET_Exh4_Fan_Start_Cmd	AV96	CONTROL	0: Stop, 1: Run	Fan control command for Exhaust #4
BACNET_Exh5_Fan_Start_Cmd	AV97	CONTROL	0: Stop, 1: Run	Fan control command for Exhaust #5
BACNET_Exh6_Fan_Start_Cmd	AV98	CONTROL	0: Stop, 1: Run	Fan control command for Exhaust #6
BACNET_Exh7_Fan_Start_Cmd	AV99	CONTROL	0: Stop, 1: Run	Fan control command for Exhaust #7
BACNET_Exh8_Fan_Start_Cmd	AV100	CONTROL	0: Stop, 1: Run	Fan control command for Exhaust #8
BACNET_Wash_Start_Zone1_Cmd	AV101	CONTROL	1: Start Wash, (0: Wash has ended)	Wash control command for Wash Zone #1
BACNET_Wash_Start_Zone2_Cmd	AV102	CONTROL	1: Start Wash, (0: Wash has ended)	Wash control command for Wash Zone #2
BACNET_Wash_Start_Zone3_Cmd	AV103	CONTROL	1: Start Wash, (0: Wash has ended)	Wash control command for Wash Zone #3
BACNET_Wash_Start_All_Zone_Cmd	AV104	CONTROL	1: Start Wash, (0: Wash has ended)	Wash control command for All Wash Zones

VFD Fault List:

0	No Fault	6	High DC Bus Voltage	12	Single Phase Fault	18-25	Internal Fault	32	Follower Lost
1	TMP Output Fault	7	Low DC Bus Voltage	13	External Fault	26	Personality Fault	33	ISO Comm Fault
2	Output (Transistor) Fault	8	Thermal Overload	14	Control Fault	27	AD Offset Fault	34	SPI Time-out
3	Ground Fault	9	OEM Fault	15	Start Error	28	Remote Keypad Lost	35	Invalid Message Received
4	High Drive Temperature	10	Illegal Setup	16	Incompatibility Fault	29	Assertion Level Fault	36	Network Time-out
5	Flying Start Fault	11	Dynamic Brake Over Temperature	17	Internal Fault 1 (EPM)	30-31	Internal Fault	37	Communication Error

Troubleshooting

The following table lists causes and corrective actions for possible problems with this control. Review this list prior to consulting manufacturer.

Troubleshooting Chart

Problem	Potential Cause	Corrective Action
Smoke Rollout of Hood at High Speed or 100% Operation	High speed set too low	Increase exhaust and supply fan variable frequency drive high speed set points
	Improper hood installation	Check for proper hood overhang, cross drafts or improper hood design
Smoke Rollout of Hood at Low Speed Operation	Low Speed set too low	Increase exhaust and supply fan variable frequency drive low speed set points
	Improper hood installation	Check for proper hood overhang, cross drafts or improper hood design
Fans Never Go to High Speed	Dirty temperature sensor	Clean grease and dirt from sensor
	High Set Point on Temperature Control Set Too High	Decrease high temperature set point. This will force the fans to high speed at a lower exhaust temperature.
Fans Never Go to Low Speed	Low Temperature set point on temperature control set too high	Reduce low temp set point by 2 degrees. This will allow cooking equipment to further cool and prevent cycling. Repeat this step until satisfied.
Fans Spin Wrong Direction	VFD Output wiring incorrect	Change the Fan direction on the Fan Setup option screens.
Exhaust Fan On and Supply Fan will not Start	Broken supply fan belt	Replace fan belt
	Fire system not armed	Fire system distributor must arm fire system
Touch Screen Interface not powered	No power into enclosure	Check main 120V power supply
Fan icon On but No Fan Comes On	Broken fan belt	Replace fan belt
	Variable frequency drive error	Clear error on variable frequency drive. Refer to drive manual.
	Loose wiring connection	Check wiring connections on VFDs
Light icon On but No Lights Come On	Light bulbs are blown	Replace hood light bulbs
	Loose wiring connection	Check light terminal block wiring connections

The following table lists Fault messages displayed on the Touch Screen and corrective actions. Review this list prior to consulting manufacturer.

Fault Message on Touch Screen	Potential Cause	Corrective Action
"Communication Loss with Controller"	Improper wiring between PLC and Touch Screen, or PLC faulted.	Verify wiring between PLC and Touch Screen. If PLC I/O LED is blinking Red, Contact Service department.
"Exh Fan # Duct Temp Outside Operating Range"	Duct temperature sensor not wired properly or no duct stat assigned to exhaust fan.	Verify duct temperature sensor wiring. Verify at least one sensor is assigned to exhaust fan through Touch Screen Fan Setup menu.
"Duct Temp Sensor # Outside Operating Range"	Duct temperature sensor not wired or not functioning properly.	Verify duct temperature sensor wiring.
"Room Temp Sensor not operating properly"	Room temperature sensor not wired or not functioning properly.	Verify room temperature sensor wiring.
"Exh# Drive Fault-See Status/Fan Status/Diagnostics"	Fault on VFD.	Go to Status/Fan Status/ Drive Diagnostics Exhaust for more details about the fault.
"Sup# Drive Fault-See Status/Fan Status/Diagnostics"	Fault on VFD.	Go to Status/Fan Status/ Drive Diagnostics Supply for more details about the fault.
"Exh# Airflow Requirement Not Met"	Fan Proving Interlock enabled. Exhaust fan not meeting its minimum calibrated Load.	Verify fan is running properly. Verify Fan Proving calibration.
"Sup# Airflow Requirement Not Met"	Fan Proving Interlock is enabled. Supply fan not meeting its minimum calibrated Load.	Verify fan is running properly. Verify Fan Proving calibration.
"Surfactant Level LOW"	Surfactant level low.	Verify Surfactant level.
"Fire Condition"	FIRE or fire circuit not wired properly.	If no fire, verify connection between terminal blocks C1 and AR1.
"PCU Filters Maintenance Required"	PCU filters clogged.	Verify PCU filters.
"CO Sensor activated"	CO sensor alarm	Verify CO level. If OK, verify CO sensor wiring.
"CORE Interlock Fault"	CORE Fault	Go to CORE Screen for more details.
"PLC Not Running"	PLC is stopped.	Verify Run Switch on PLC controller (under little trap door used for programming) is set all the way to the top. Contact Service department.

MAINTENANCE

To guarantee trouble free operation of this control, the manufacturer suggests following these guidelines. Most problems associated with unit failures are directly related to poor service and maintenance.

Please record any maintenance or service performed on this equipment in the documentation section located at the end of this manual.

WARNING: DO NOT ATTEMPT MAINTENANCE ON THIS CONTROL UNTIL THE ELECTRICAL SUPPLY HAS BEEN COMPLETELY DISCONNECTED

General Maintenance

1. Control enclosure should be kept clean and free from any grease or dirt build-up.
2. All fasteners should be checked for tightness each time maintenance checks are performed prior to restarting unit.
3. Control enclosure door panel should be securely closed after maintenance to prevent tampering or electrical shock.

Every Month

1. **Temperature sensor(s)** in exhaust hood riser(s) need to be cleaned by wiping any grease or dust build-up from probe with a clean cloth. A clean sensor ensures that the temperature switch will quickly respond to changes in exhaust air temperature.
2. Check all fasteners, sensors, and electrical connections for proper tightness and continuity.

Self-Cleaning

Please refer to the Self-Cleaning Manual for Installation, Operation, and Maintenance of the Self-Cleaning system.

