

Standard and Modular Centrifugal Untempered Supply Fans Installation, Operation, and Maintenance Manual

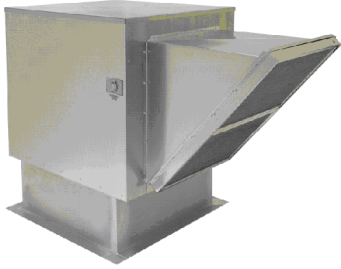

Standard Untempered Supply Fan

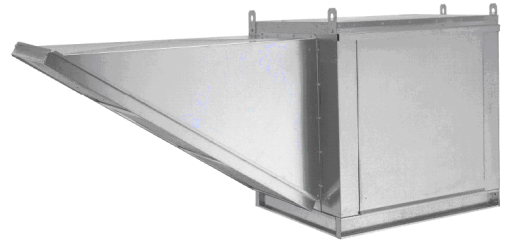

Modular Untempered Supply Fan



INLINE Filtered Supply Fan

RECEIVING AND INSPECTION

Upon receiving unit, check for any interior and exterior damage, and if found, report it immediately to the carrier. Also check that all accessory items are accounted for and are damage free. Turn the blower wheel by hand to verify free rotation and check the damper (if supplied) for free operation.

WARNING!!

Installation of this ventilator should only be performed by a qualified professional who has read and understands these instructions and is familiar with proper safety precautions. Improper installation poses serious risk of injury due to electric shock, contact with rotating equipment, and other potential hazards. Read this manual thoroughly before installing or servicing this equipment. **ALWAYS** disconnect power prior to working on fan.

Save these instructions. This document is the property of the owner of this equipment and is required for future maintenance. Leave this document with the owner when installation or service is complete.

TABLE OF CONTENTS

WARRANTY.....	3
INSTALLATION.....	4
Mechanical.....	4
Site Preparation.....	4
Intake Assembly.....	4
Curb and Ductwork.....	4
Roof Mount Installation.....	5
Wall Mount Installation.....	5
Indoor (Inline) Installation.....	6
Installation with Exhaust Fan.....	6
Electrical.....	7
Motorized Intake Damper.....	7
Fan to Building Wiring Connection.....	8
OPERATION.....	9
Start Up.....	9
Special Tools Required.....	9
Start Up Procedure.....	9
Pulley Adjustment.....	10
Pulley Alignment.....	10
Proper Belt Tension.....	10
Pulley Combination Chart.....	11
Troubleshooting.....	12
Troubleshooting Chart.....	12
MAINTENANCE.....	13
General Maintenance.....	13
2 weeks after startup.....	13
Every 3 months.....	13
Filter Quantity Chart.....	14
Yearly.....	14
Start-Up and Maintenance Documentation.....	15
Job Information.....	15
Fan Unit Information.....	15
Maintenance Record.....	15
Factory Service Department.....	15

WARRANTY

This equipment is warranted to be free from defects in materials and workmanship, under normal use and service, for a period of 12 months from date of shipment. This warranty shall not apply if:

1. The equipment is not installed by a qualified installer per the MANUFACTURER'S installation instructions shipped with the product,
2. The equipment is not installed in accordance with federal, state and local codes and regulations,
3. The equipment is misused or neglected,
4. The equipment is not operated within its published capacity,
5. The invoice is not paid within the terms of the sales agreement.

The MANUFACTURER shall not be liable for incidental and consequential losses and damages potentially attributable to malfunctioning equipment. Should any part of the equipment prove to be defective in material or workmanship within the 12-month warranty period, upon examination by the MANUFACTURER, such part will be repaired or replaced by MANUFACTURER at no charge. The BUYER shall pay all labor costs incurred in connection with such repair or replacement. Equipment shall not be returned without MANUFACTURER'S prior authorization and all returned equipment shall be shipped by the BUYER, freight prepaid to a destination determined by the MANUFACTURER.

INSTALLATION

It is imperative that this unit is installed and operated with the designed airflow and electrical supply in accordance with this manual. If there are any questions about any items, please call the service department at **1-866-784-6900** for warranty and technical support issues.

Mechanical

WARNING: DO NOT RAISE VENTILATOR BY THE INTAKE HOOD, BLOWER OR MOTOR SHAFT, OR BEARINGS – USE LIFTING LUGS PROVIDED OR A SLING

Site Preparation

1. Provide clearance around installation site to safely rig and lift equipment into its final position. Supports must adequately support equipment. Refer to manufacturer's estimated weights.
2. Consider general service and installation space when locating unit.
3. Locate unit close to the space it will serve to reduce long, twisted duct runs.
4. Do not allow air intake to face prevailing winds. Support unit above ground or at roof level high enough to prevent precipitation from being drawn into its inlet. The inlet must also be located at least 10 feet away from any exhaust vents. The fan inlet shall be located in accordance with the applicable building code provisions for ventilation air.

Intake Assembly

Filters and intake hoods for standard supply fans are shipped inside the supply fan housing for protection during shipping. Modular intakes are shipped on a separate skid. Upon unit arrival, follow the following procedure to assemble the intake to the fan:

1. Remove the fan top (standard supply fans only).
2. Remove the intake hood and filters from the fan housing.
3. Re-install the fan top (standard supply fans only).
4. Apply silicone or weather-proof gasket on the back side of the flanges of the intake hood.
5. Screw the flanges of the intake hood to the unit at the hatched areas shown with the supplied sheet metal screws. Place caulk on the outside of the screws to prevent water leaks. Slide the filters down the filter track as shown.

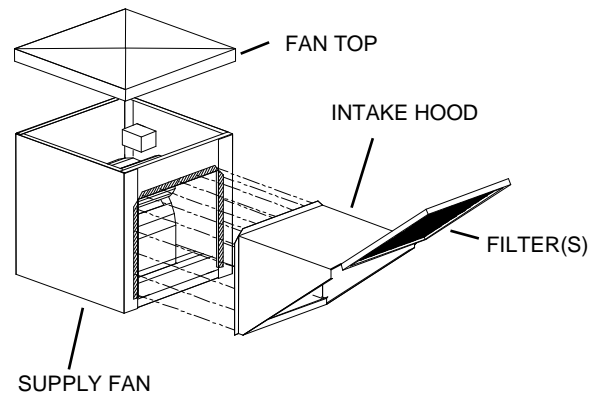

Curb and Ductwork

This fan was specified for a specific CFM and static pressure. The ductwork attached to this unit will significantly affect the airflow performance. Flexible ductwork and square elbows should not be used. Also, transitions and turns in ductwork near the fan outlet will cause system effect and will drastically increase the static pressure and reduce airflow. The chart to the right shows the minimum fan outlet duct sizes and straight lengths recommended for optimal fan performance.

Recommended Supply Ductwork Sizes

Blower Size	Duct Size	Straight Duct Length
10	14 x 14	48 in.
12	16 x 16	54 in.
15	20 x 20	72 in.
18	24 x 24	86 in.
20	26 x 26	108 in.
25	32 x 32	168 in.

Follow **SMACNA guides and recommendations for the remaining duct run**. Fans designed for rooftop installation should be installed on a prefabricated or factory built roof curb. Follow curb manufacturer's instructions for proper curb installation. The unit should be installed on a curb and/or rail elevated not less than 14" above any surface. Be sure duct connection and fan outlet are properly aligned and sealed. Secure fan to curb through vertical portion of the ventilator base assembly flange using a minimum of eight (8) lug screws, anchor bolts, or other suitable fasteners (not furnished). Shims may be required depending upon curb installation and roofing material. Check all fasteners for tightness. The diagrams below show different mechanical installation configurations.

Roof Mount Installation

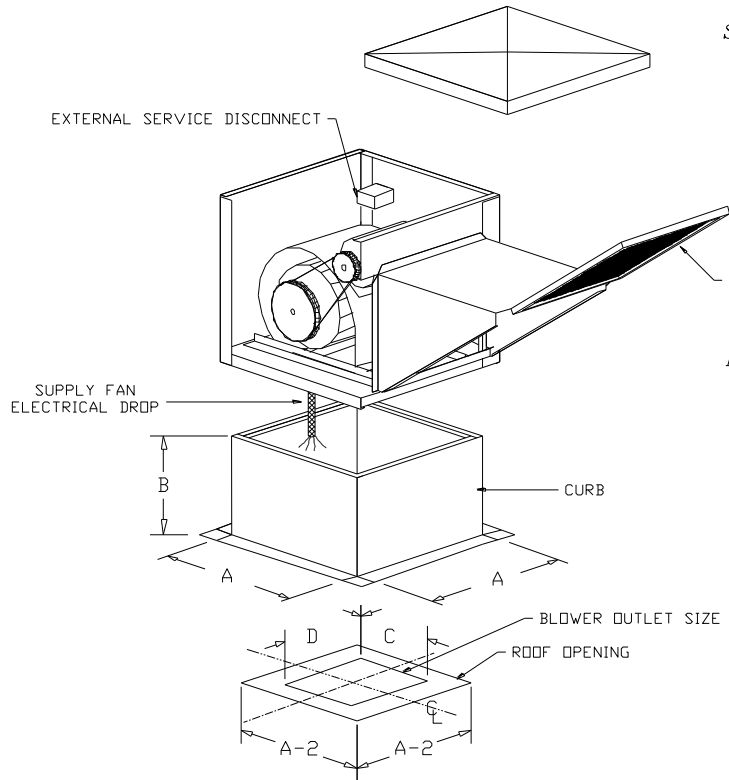

STANDARD CURB/ROOFTOP DIMENSIONAL DATA

MODEL	BLOWER	A	B	C	D
Size 1	10"	23	14	11-3/4	13-1/2
Size 2	12"	32-1/2	14	13-3/4	15-7/8
	15"			16-1/8	18-7/8

MODULAR CURB/ROOFTOP DIMENSIONAL DATA

MODEL	BLOWER	A	B	C	D
Size 1	10"	21	20	11-3/4	13-1/2
Size 2	12"	31	20	13-3/4	15-7/8
	15"			16-1/8	18-7/8
Size 3	18"	35	20	18-7/8	21-7/8
Size 4	20"	42	20	24-5/8	24-5/8
Size 5	25"	52-1/4	20	31-1/8	31-1/8

Wall Mount Installation

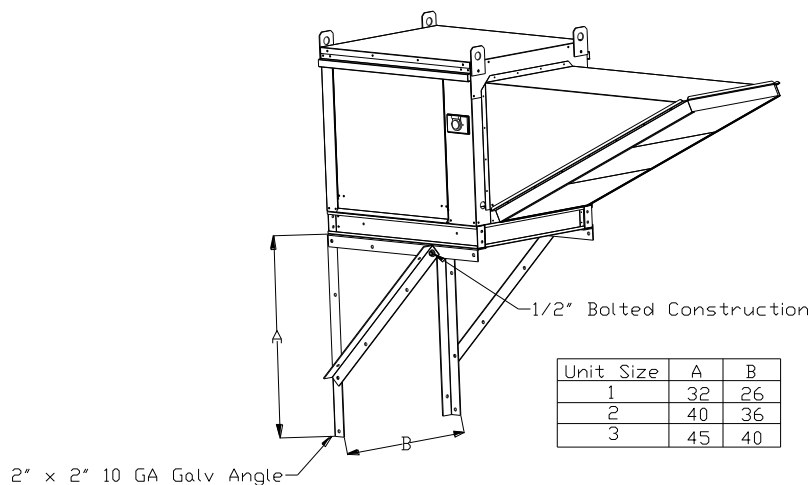

Unit Size	A	B
1	32	26
2	40	36
3	45	40

Indoor (Inline) Installation

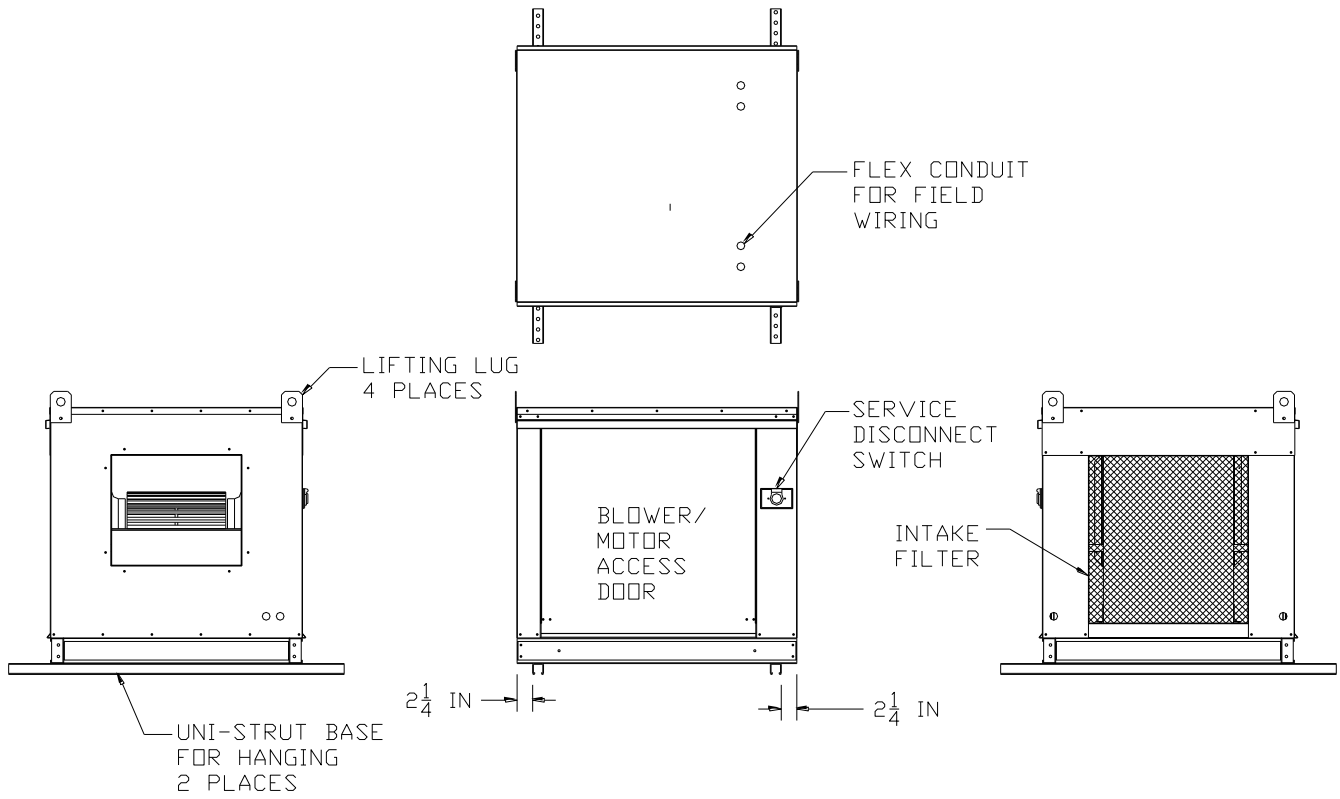

Installation with Exhaust Fan

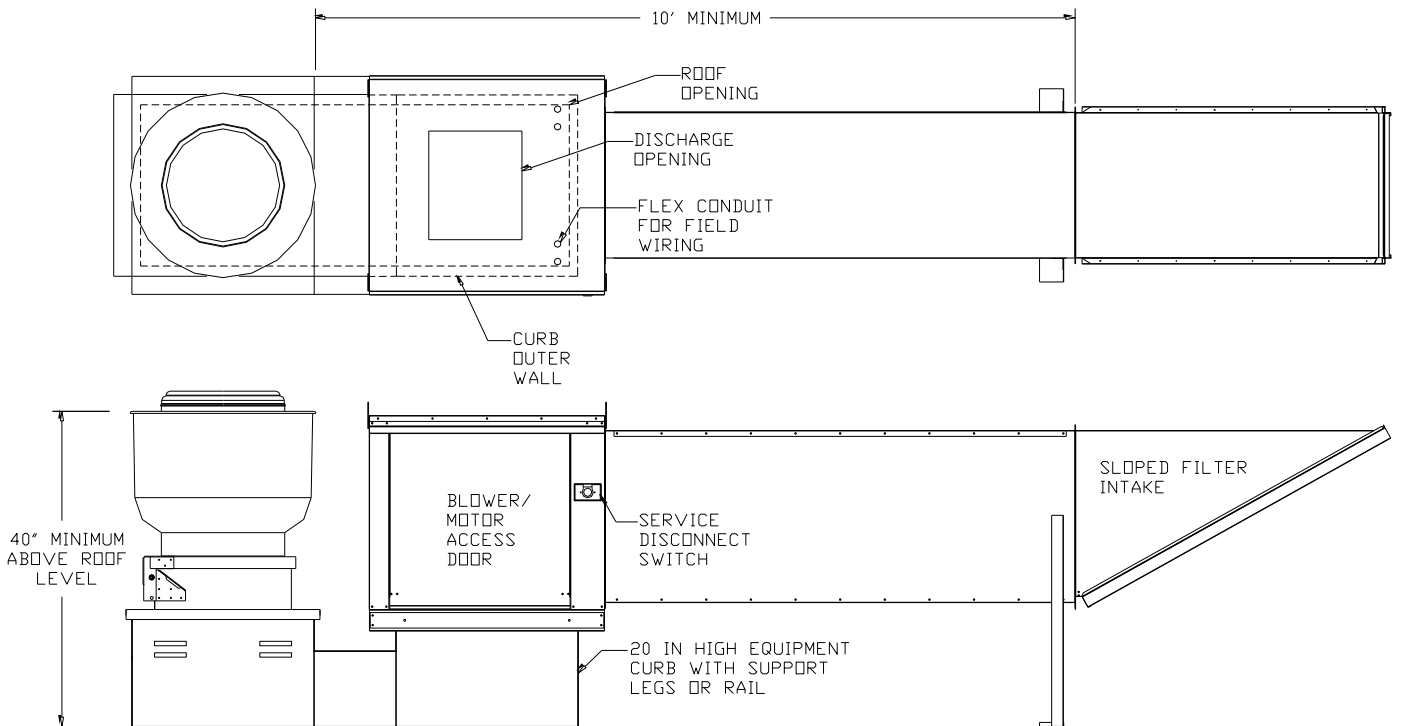

Electrical

Before connecting power to the fan, read and understand this entire section of this document. As-built wiring diagrams are furnished with each fan by the factory, and are attached either to the door of the unit or the blower.

Electrical wiring and connections should be done in accordance with local ordinances and the National Electric Code, ANSI/NFPA70. Be sure the voltage and phase of the power supply and the wire amperage capacity is in accordance with the motor nameplate. For additional safety information refer to AMCA publication 410-96, *Recommended Safety Practices for Users and Installers of Industrial and Commercial Fans*.

1. Always **disconnect power** before working on or near a fan. Lock and tag the disconnect switch or breaker to prevent accidental power up.
2. An electrical drop containing the line voltage power wiring is shipped with every fan. The electrical drop should be brought through one of the conduit openings located in the base of the unit, run through the curb, and connected to a junction box inside the building.
3. A dedicated branch circuit should supply the motor circuit with short circuit protection according to the National Electric Code. This dedicated branch should be run to the junction box mentioned above and connected as shown in a following illustration labeled "Fan to Building Wiring Connection".
4. Make certain that the power source is compatible with the requirements of your equipment. The fan nameplate identifies the **proper phase and voltage** of the motor.
5. Before connecting fan to building power source, verify power line wiring is de-energized.
6. Secure the power cable to prevent contact with sharp objects.
7. Do not kink power cable and never allow the cable to come in contact with oil, grease, hot surfaces or chemicals.
8. Before powering up fan check fan wheel for free rotation and make sure that the interior of the fan is free of loose debris or shipping materials.
9. If any of the original wire supplied with the fan must be replaced, it must be replaced with type THHN wire or equivalent.

WARNING!!
Disconnect power before installing or servicing fan. High voltage electrical input is needed for this equipment. This work should be performed by a qualified electrician.

Copper Wire Ampacity

Wire Size AWG	Maximum Amps
14	15
12	20
10	30
8	50
6	65
4	85

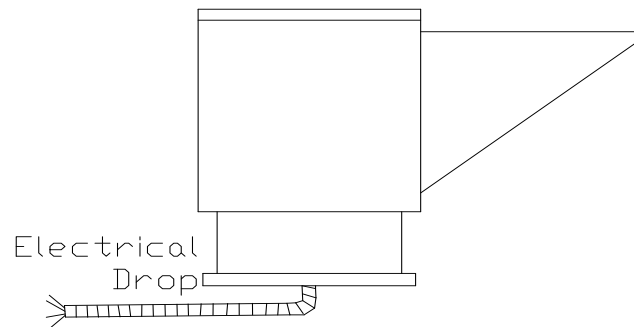

Motorized Intake Damper

On units shipped with the optional motorized intake damper, a power transformer is supplied with the unit if the main incoming voltage is greater than 120V. The damper motor is automatically energized when the main disconnect switch is in the ON position. **No external wiring to the damper motor is required.**

Fan to Building Wiring Connection

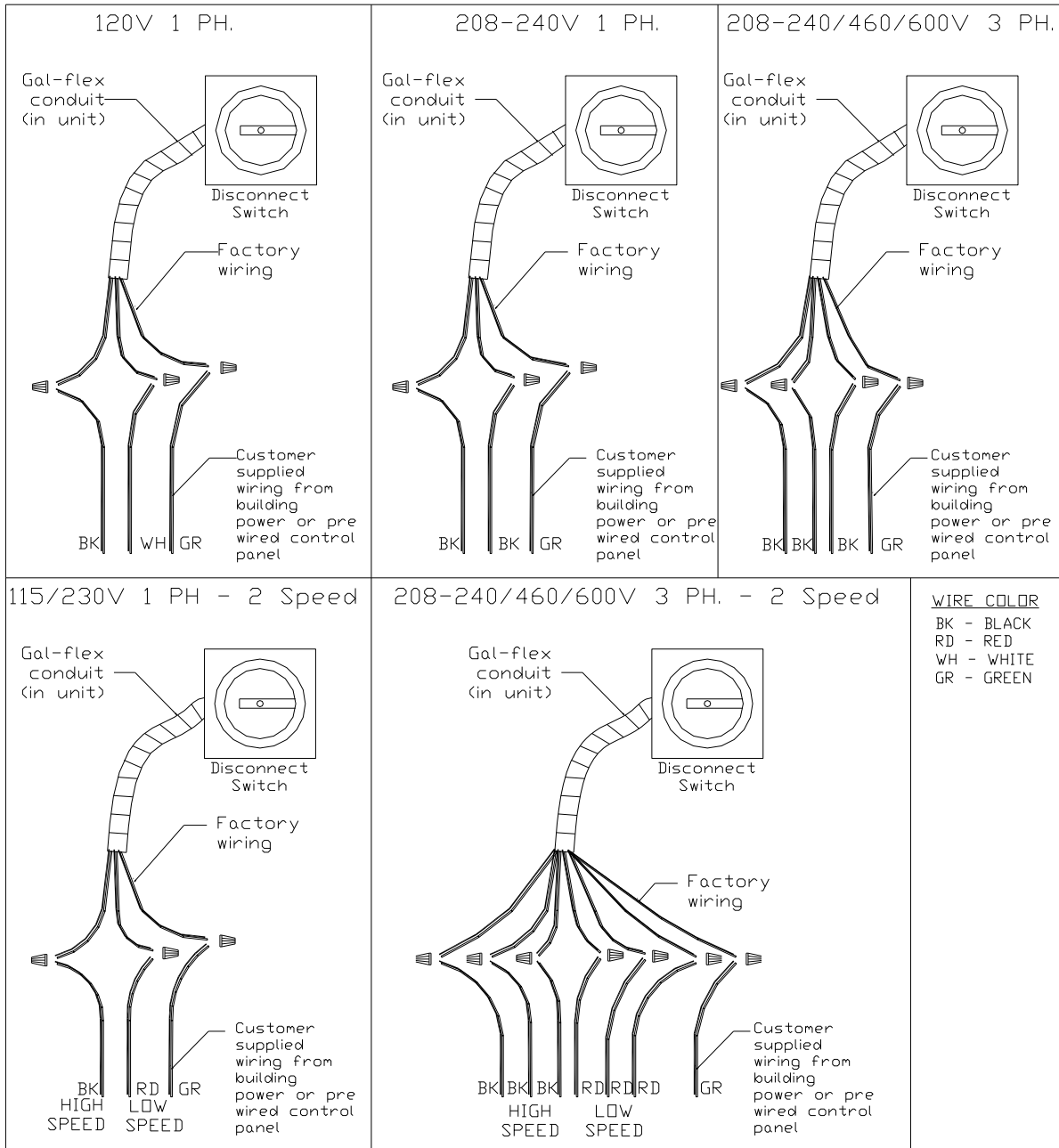

OPERATION

Prior to starting up or operating the ventilator, check all fasteners for tightness. In particular, check the set screw in the wheel hub, bearings and the fan sheaves (pulleys). With power to the fan **OFF** or prior to connecting ventilator to power, turn the fan wheel by hand to be sure it is not striking the inlet or any obstacles. Re-center if necessary.

Start Up

Special Tools Required

- AC Voltage Meter
- Tachometer
- Amperage Meter
- Standard Hand Tools

Start Up Procedure

1. Check all electrical connections for tightness and continuity.
2. Check pulley alignment and belt tension as described below.
3. Inspect the condition of the intake damper and damper linkage, if provided.
4. Inspect the air-stream for obstructions and install intake filters if missing.
5. Compare the supplied **voltage** with the fan's nameplate voltage. If this does not match, correct the problem.
6. Start the fan up, by turning the external disconnect to the **ON** position, and shut it **OFF** immediately to **check rotation of the wheel** with the directional arrow on the blower scroll. Reversed rotation will result in poor air performance, motor overloading and possible burnout. For units equipped with a single-phase motor check the motor wiring diagram to change rotation. For 3-phase motors, any two power leads can be interchanged to reverse motor direction.
7. When the fan is started up, observe the operation and check for any unusual noises.
8. Switch the external disconnect back to the **ON** position and with the air system in full operation and all ducts attached, measure the system airflow. Motor sheave (pulley) is variable pitch, and allows for an increase or decrease of the fan RPM to adjust the airflow, as shown in the illustration below. For your convenience, a RPM chart is included in the following pages.
9. Once the proper airflow is achieved, measure and record the fan speed with a reliable tachometer. **Caution - Excessive speed will result in motor overloading or bearing failure. Do not set fan RPMs higher than specified in the maximum RPM chart.** See the troubleshooting guide for more information.
10. Measure and record the **voltage** and **amperage** to the motor and compare with the motor nameplate to determine if the motor is operating under safe load condition.
11. Once the rpm of the ventilator has been properly set, disconnect power and recheck belt tension and pulley alignment as described below.

Maximum RPM and HP Chart

Blower Size	Maximum RPM	Maximum HP
10"	1800	2
12"	1500	3
15"	1400	5
18"	1200	5
20"	1000	10
25"	900	20

Pulley Adjustment Illustration

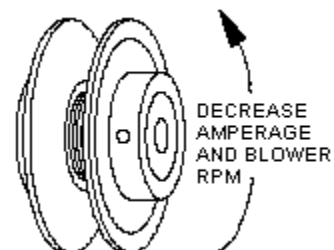

Pulley Adjustment

The adjustable motor pulley is factory set for the RPM specified. Speed can be increased by closing or decreased by opening the adjustable motor sheave. Two groove variable pitch pulleys must be adjusted an equal number of turns open or closed. Any increase in speed represents a substantial increase in horsepower required by the unit. Motor amperage should always be checked to avoid serious damage to the motor when the speed is varied. Always torque setscrews according to the setscrew torque chart.

Pulley Setscrew Torque

Thread Size	Torque (IN/Lb)
No. 10 (bushing)	32
1/4" (bushing)	72
5/16"	130

Pulley Alignment

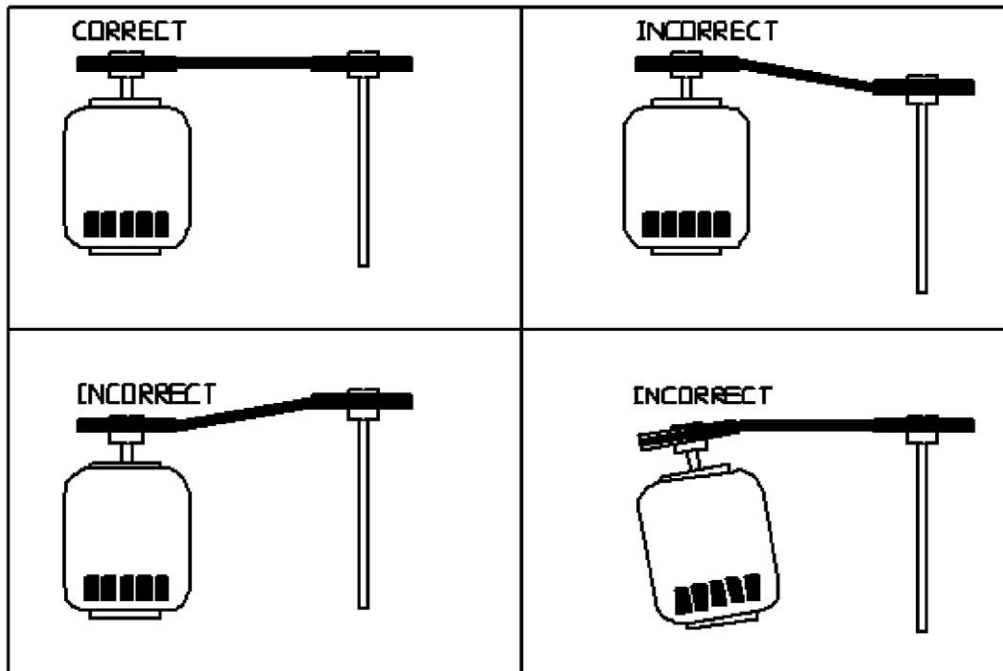

Proper Belt Tension

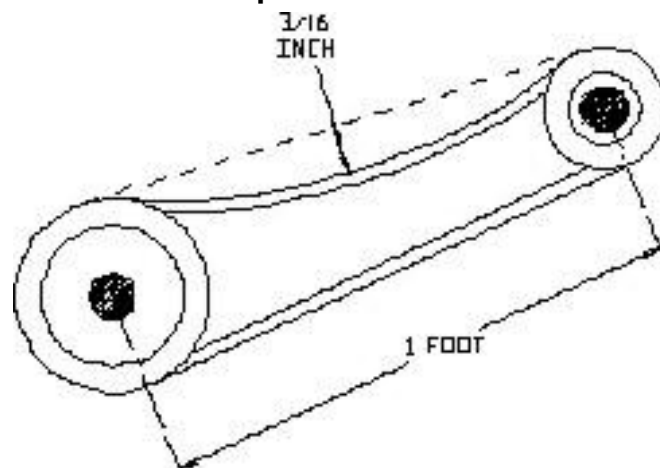

Pulley Combination Chart

Motor RPM		1725															
1/3 to 1-1/2 HP AX BELTS		MOTOR PULLEY 1VL34		Dd1 1.9	Dd2 2.9	Pd1 2	Pd2 3	TURNS ON MOTOR PULLEY									
				Open												Closed	
BLOWER PULLEY	DATUM DIAMETER	PITCH DIAMETER	5	4 1/2	4	3 1/2	3	2 1/2	2	1 1/2	1	1/2	0				
AK114	11	11.2	308	323	339	354	370	385	400	416	431	447	462				
1/3 to 2 HP AX BELTS		MOTOR PULLEY 1VL40		Dd1 2.4	Dd2 3.4	Pd1 2.6	Pd2 3.6	TURNS ON MOTOR PULLEY									
				Open												Closed	
BLOWER PULLEY	DATUM DIAMETER	PITCH DIAMETER	5	4 1/2	4	3 1/2	3	2 1/2	2	1 1/2	1	1/2	0				
AK114	11	11.2	400	416	431	447	462	477	493	508	524	539	554				
AK94	9	9.2	488	506	525	544	563	581	600	619	638	656	675				
AK79	7.5	7.7	582	605	627	650	672	694	717	739	762	784	806				
AK66	6.2	6.4	701	728	755	782	809	836	863	889	916	943	970				
AK54	5	5.2	863	896	929	962	995	1028	1062	1095	1128	1161	1194				
AK46	4.2	4.4	1019	1059	1098	1137	1176	1215	1255	1294	1333	1372	1411				
AK39	3.5	3.7	1212	1259	1305	1352	1399	1445	1492	1539	1585	1632	1678				
AK32	3	3.2	1402	1455	1509	1563	1617	1671	1725	1779	1833	1887	1941				
3 to 5 HP BX BELTS		MOTOR PULLEY 2VP42		Dd1 2.9	Dd2 3.9	Pd1 3	Pd2 4	TURNS ON MOTOR PULLEY									
				Open												Closed	
BLOWER PULLEY	DATUM DIAMETER	PITCH DIAMETER	6	5 1/2	5	4 1/2	4	3 1/2	3	2 1/2	2	1 1/2	1	1/2	0		
2BK160H	15.4	15.7	330	339	348	357	366	375	385	394	403	412	421	430	439		
2BK140H	13.4	13.7	378	388	399	409	420	430	441	451	462	472	483	493	504		
2BK120H	11.4	11.7	442	455	467	479	491	504	516	528	541	553	565	577	590		
2BK110H	10.4	10.7	484	497	511	524	537	551	564	578	591	605	618	631	645		
2BK100H	9.4	9.7	534	548	563	578	593	608	622	637	652	667	682	697	711		
2BK90H	8.4	8.7	595	611	628	644	661	677	694	710	727	744	760	777	793		
2BK80H	7.4	7.7	672	691	709	728	747	765	784	803	821	840	859	877	896		
2BK70H	6.4	6.7	772	794	815	837	858	880	901	923	944	965	987	1008	1031		
2BK60H	5.4	5.7	908	933	958	984	1009	1034	1059	1084	1110	1135	1160	1185	1211		
2BK55H	4.9	5.2	995	1023	1050	1078	1106	1133	1161	1189	1216	1244	1272	1299	1327		
2BK50H	4.4	4.7	1101	1132	1162	1193	1223	1254	1285	1315	1346	1376	1407	1438	1468		
7-1/2 to 10 HP BX BELTS		MOTOR PULLEY 2VP60		Dd1 4.3	Dd2 5.5	Pd1 4.7	Pd2 5.9	TURNS ON MOTOR PULLEY									
				Open												Closed	
BLOWER PULLEY	DATUM DIAMETER	PITCH DIAMETER	6	5 1/2	5	4 1/2	4	3 1/2	3	2 1/2	2	1 1/2	1	1/2	0		
2BK160H	15.4	15.7	516	527	538	549	560	571	582	593	604	615	626	637	648		
2BK140H	13.4	13.7	592	604	617	630	642	655	667	680	693	705	718	730	743		
2BK120H	11.4	11.7	693	708	722	737	752	767	781	796	811	826	840	855	870		
2BK110H	10.4	10.7	758	774	790	806	822	838	854	871	887	903	919	935	951		
2BK100H	9.4	9.7	836	854	871	889	907	925	943	960	978	996	1014	1031	1049		
2BK90H	8.4	8.7	932	952	972	991	1011	1031	1051	1071	1091	1110	1130	1150	1170		
2BK80H	7.4	7.7	1053	1075	1098	1120	1143	1165	1187	1210	1232	1255	1277	1299	1322		
3 to 5 HP BX BELTS		MOTOR PULLEY 2VP42		Dd1 2.9	Dd2 3.9	Pd1 3	Pd2 4	TURNS ON MOTOR PULLEY									
				Open												Closed	
BLOWER PULLEY	DATUM DIAMETER	PITCH DIAMETER	6	5 1/2	5	4 1/2	4	3 1/2	3	2 1/2	2	1 1/2	1	1/2	0		
2BSV278	27.8	28.1	184	189	194	200	205	210	215	220	225	230	235	240	246		
2BSV250	25	25.3	205	210	216	222	227	233	239	244	250	256	261	267	273		
2BSV234	23.4	23.7	218	224	230	237	243	249	255	261	267	273	279	285	291		
2BSV200	20	20.3	255	262	269	276	283	290	297	304	312	319	326	333	340		
2BSV184	18.4	18.7	277	284	292	300	307	315	323	331	338	346	354	361	369		
2BSV160	16	16.3	317	326	335	344	353	362	370	379	388	397	406	414	423		
2BSV154	15.4	15.7	330	339	348	357	366	375	385	394	403	412	421	430	439		
2BSV136	12.6	12.9	401	412	423	435	446	457	468	479	490	501	513	524	535		
2BSV124	12.4	12.7	407	419	430	441	453	464	475	487	498	509	521	532	543		
2BSV110	11	11.3	458	471	483	496	509	522	534	547	560	572	585	598	611		
7-1/2 to 10 HP BX BELTS		MOTOR PULLEY 2VP60		Dd1 4.3	Dd2 5.5	Pd1 4.7	Pd2 5.9	TURNS ON MOTOR PULLEY									
				Open												Closed	
BLOWER PULLEY	DATUM DIAMETER	PITCH DIAMETER	6	5 1/2	5	4 1/2	4	3 1/2	3	2 1/2	2	1 1/2	1	1/2	0		
2BSV278	27.8	28.1	289	295	301	307	313	319	325	331	338	344	350	356	362		
2BSV250	25	25.3	320	327	334	341	348	355	361	368	375	382	389	395	402		
2BSV234	23.4	23.7	342	349	357	364	371	378	386	393	400	408	415	422	429		
2BSV200	20	20.3	399	408	416	425	433	442	450	459	467	476	484	493	501		
2BSV184	18.4	18.7	434	443	452	461	470	480	489	498	507	517	526	535	544		
2BSV160	16	16.3	497	508	519	529	540	550	561	571	582	593	603	614	624		
2BSV154	15.4	15.7	516	527	538	549	560	571	582	593	604	615	626	637	648		
2BSV136	12.6	12.9	628	642	655	669	682	695	709	722	735	749	762	776	789		
2BSV124	12.4	12.7	638	652	666	679	693	706	720	733	747	761	774	788	801		
2BSV110	11	11.3	717	733	748	763	779	794	809	824	840	855	870	885	901		
15 to 20 HP BX BELTS		MOTOR PULLEY 2VP75		Dd1 5.8	Dd2 7	Pd1 6.2	Pd2 7.4	TURNS ON MOTOR PULLEY									
				Open												Closed	
BLOWER PULLEY	DATUM DIAMETER	PITCH DIAMETER	6	5 1/2	5	4 1/2	4	3 1/2	3	2 1/2	2	1 1/2	1	1/2	0		
2BSV278	27.8	28.1	381	387	393	399	405	411	417	424	430	436	442	448	454		
2BSV250	25	25.3	423	430	436	443	450	457	464	470	477	484	491	498	505		
2BSV234	23.4	23.7	451	459	466	473	480	488	495	502	509	517	524	531	539		
2BSV200	20	20.3	527	535	544	552	561	569	578	586	595	603	612	620	629		
2BSV184	18.4	18.7	572	581	590	600	609	618	627	636	646	655	664	673	683		
2BSV160	16	16.3	656	667	677	688	698	709	720	730	741	751	762	773	783		
2BSV154	15.4	15.7	681	692	703	714	725	736	747	758	769	780	791	802	813		
2BSV136	12.6	12.9	829	842	856	869	883	896	909	923	936	949	963	976	990		

** 2HP Motors on 20 IN Blowers use 2VP42 Pulleys

Troubleshooting

The following table lists causes and corrective actions for possible problems with the fan units. Review this list prior to consulting manufacturer.

Troubleshooting Chart

Problem	Potential Cause	Corrective Action
Fan Inoperative	Blown fuse or open circuit breaker	Replace fuse or reset circuit breaker and check amps
	Disconnect switch in "Off" position	Turn to "On" position
	Motor wired incorrectly	Check motor wiring to wiring diagram located on fan motor
	Broken fan belt	Replace belt
	Motor starter overloaded	Reset starter and check amps
Motor Overload	Fan rotating in the wrong direction	Be sure fan is rotating in the direction shown on rotation label
	Fan speed is too high	Reduce fan RPM
	Motor wired incorrectly	Check motor wiring to wiring diagram located on fan motor
	Overload in starter set too low	Set overload to motor FLA value
	Motor HP too low	Determine if HP is sufficient for job
	Duct static pressure lower than design	Reduce fan RPM
Insufficient Airflow	Fan rotating in the wrong direction	Be sure fan is rotating in the direction shown on rotation label
	Poor outlet conditions	There should be a straight clear duct at the outlet
	Intake damper not fully open	Inspect damper linkage and replace damper motor if needed
	Duct static pressure higher than design	Improve ductwork to eliminate or reduce duct losses
	Blower speed too low	Increase fan RPM. Do not overload motor
	Supply grills or registers closed	Open and adjust
	Dirty or clogged filters	Clean and/or replace
	Belt slippage	Adjust belt tension
Excessive Airflow	Blower speed too high	Reduce fan RPM
	Filters not installed	Install filters
	Duct static pressure lower than design	Reduce fan RPM
Excessive Vibration and Noise	Misaligned pulleys	Align pulleys
	Damaged or unbalanced wheel	Replace wheel
	Fan is operating in the unstable region of the fan curve	Refer to performance curve for fan
	Bearings need lubrication or replacement	Lubricate or replace
	Fan speed is too high	Reduce fan RPM
	Belts too loose, worn or oily	Inspect and replace if needed

MAINTENANCE

To guarantee trouble free operation of this fan, the manufacturer suggests following these guidelines. Most problems associated with fan failures are directly related to poor service and maintenance.

Please record any maintenance or service performed on this fan in the documentation section located at the end of this manual.

WARNING: DO NOT ATTEMPT MAINTENANCE ON THE FAN UNTIL THE ELECTRICAL SUPPLY HAS BEEN COMPLETELY DISCONNECTED

General Maintenance

1. Fan inlet and approaches to ventilator should be kept clean and free from any obstruction.
2. Motors are normally permanently lubricated. Check bearings periodically. If they have grease fittings lubricate each season. Use caution when lubricating bearings, wipe the fittings clean, the unit should be rotated by hand while lubricating. **Caution: Use care when touching the exterior of an operating motor. Motors normally run hot and may be hot enough to be painful or cause injury.**
3. All fasteners should be checked for tightness each time maintenance checks are performed prior to restarting unit.
4. Blowers require very little attention when moving clean air. Occasionally oil and dust may accumulate causing imbalance. If the fan is installed in a corrosive or dirty atmosphere, periodically inspect and clean the wheel, inlet and other moving parts to ensure smooth and safe operation.

2 weeks after startup

1. Belt tension should be checked after the first 2 weeks of fan operation. Belts tend to stretch and settle into pulleys after an initial start-up sequence. **Do not tension belts by changing the setting of the motor pulley**, this will change the fan speed and may damage the motor. To re-tension belts, turn the power to the fan motor OFF. Loosen the fasteners that hold the blower scroll plate to the blower. Rotate the motor to the left or right to adjust the belt tension. Belt tension should be adjusted to allow 1/64" of deflection per inch of belt span. Exercise extreme care when adjusting V-belts as not to misalign pulleys. Any misalignment will cause a sharp reduction in belt life and produce squeaky noises. Over-tightening will cause excessive belt and bearing wear as well as noise. Too little tension will cause slippage at startup and uneven wear. **Whenever belts are removed or installed, never force belts over pulleys without loosening motor first to relieve belt tension.** When replacing belts, use the same type as supplied by the manufacturer. On units shipped with double groove pulleys, matched belts should always be used.
2. All fasteners should be checked for tightness each time maintenance checks are performed prior to restarting unit.

Every 3 months

1. Belt tension should be checked quarterly. See instructions in the previous maintenance section. Over-tightening will cause excessive bearing wear and noise. Too little tension will cause slippage at startup and uneven wear.
2. Filters need to be cleaned and/or replaced quarterly, and more often in severe conditions. Washable filters can be washed in warm soapy water. When re-installing filters, be sure to install with the **airflow in the correct direction** as indicated on the filter.

Filter Quantity Chart

Intake	16" x 20"	20" x 25"
Size 1 Standard Sloped	2	
Size 2 Standard Sloped		2
Size 1 Modular Sloped	3	
Size 2 Modular Sloped		3
Size 3 Modular Sloped	6	
Size 4 Modular Sloped	10	
Size 5 Modular Sloped		8
Size 1 V-Bank		3
Size 2 V-Bank	8	
Size 3 V-Bank		8
Size 4 V-Bank	15	
Size 5 V-Bank		12
Size 1 INLINE	1	
Size 2 INLINE		1
Size 3 INLINE		2

Yearly

1. Inspect bearings for wear and deterioration. Replace if necessary.
2. Inspect belt wear and replace torn or worn belts.
3. Inspect bolts and set screws for tightness. Tighten as necessary.
4. Inspect motor for cleanliness. Clean exterior surfaces only. Remove dust and grease from the motor housing to ensure proper motor cooling. Remove dirt and grease from the wheel and housing to prevent imbalance and damage.

