

# Instructions to Change Supply Blower Orientation

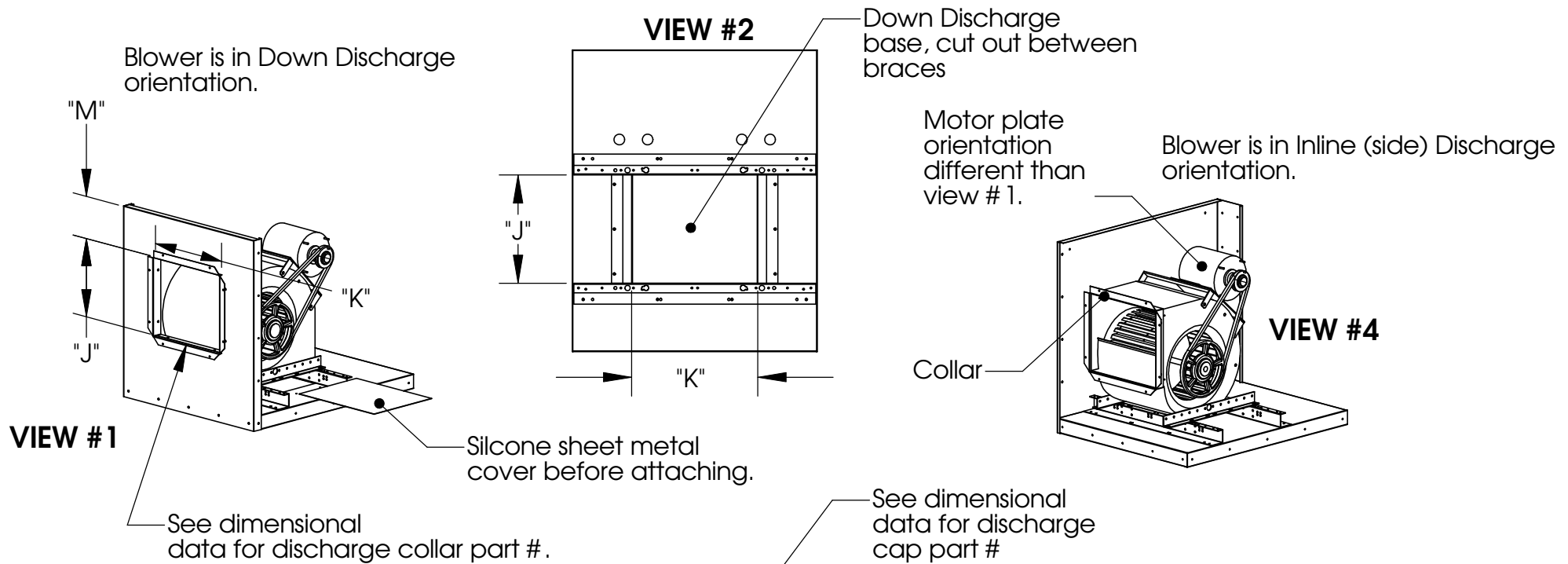

## Instructions: (Down to Side Discharge)

1. Disconnect power and remove lid or access doors.
2. Remove the hardware that fastens the blower to the blower rails.
3. Disconnect the motor and motor plate from the blower.
4. Remove the blower from the housing.
5. Cover the old outlet hole using a flat piece of sheet metal. Apply silicone to the sheet metal before fastening to the base.
6. The front panel will have to be cut. Use the dimensional data provided, or make sure the blower is in the correct orientation (see view #4) to mark and cut.
7. Once the front panel has been cut, attach the discharge collar, (see dimensional data for part number). Rivet or screw the discharge collar to the outlet in the front panel. Collars are used to reduce air loss between the blower and the front panel.
8. The blower outlet must be inside the discharge collar before fastening the blower to the horizontal supports.
9. Mount the motor plate and motor. (see view #4).
- 10. Reset the belt tension before reconnecting power.**
11. Attach the lid or install access doors and turn on the disconnect switch.

## Instructions: (Side to Down Discharge)

1. Disconnect power and remove lid or access doors.
2. Remove the hardware that fastens the blower to the blower rails.
3. Disconnect the motor and motor plate from the blower.
4. Remove the blower from the housing.
5. Cover the old outlet hole using a flat piece of sheet metal. Apply silicone to the sheet metal before fastening to the front panel.
6. Discharge caps have to be riveted or screwed to the base (see view #3 for details).
7. Once the discharge caps have been attached, cut the outlet hole in the base. Use the dimensional data or see view # 2. The blower supports actually outline the area to be cut out in the base.
8. Attach the blower to the horizontal supports (for blower orientation see view #1). Make sure that the blower is secure and that the outlet is inside the discharge caps.
9. Mount the motor plate and motor. (see view #1)
- 10. Reset the belt tension before reconnecting power.**
11. Attach the lid or install access doors and turn on the disconnect switch.

Dimensional Data Side & Down Discharge					
Blower Size	"J"	"K"	"M"	Collar Part #	Dis Cap Part #
10	11 1/2	13 1/4	6 1/4	B1G10COL	B1G10DCP
12	13 9/16	15 3/4	10	B2G12COL	B2G12DCP
15	16	18 3/4	6 1/2	B2G15COL	B2G15DCP
18	19	22	16 1/2	B3G18COL	B3G18DCP
20	24 7/8	24 7/8	17	B4920COL	B4920DCP
25	31 3/8	31 3/8	11 1/16	B5925COL*	B5925DCP

\* 2 B5925COL parts required.  
2 DCP Parts required for all sizes.

**On Heated Supply Units, the mixing tube and freeze stat sensor (when provided) must be moved to the opposite side of the blower when discharge orientation is changed.**