

Non-Welded Double Wall Grease Duct Systems Installation, Operation, and Maintenance Manual

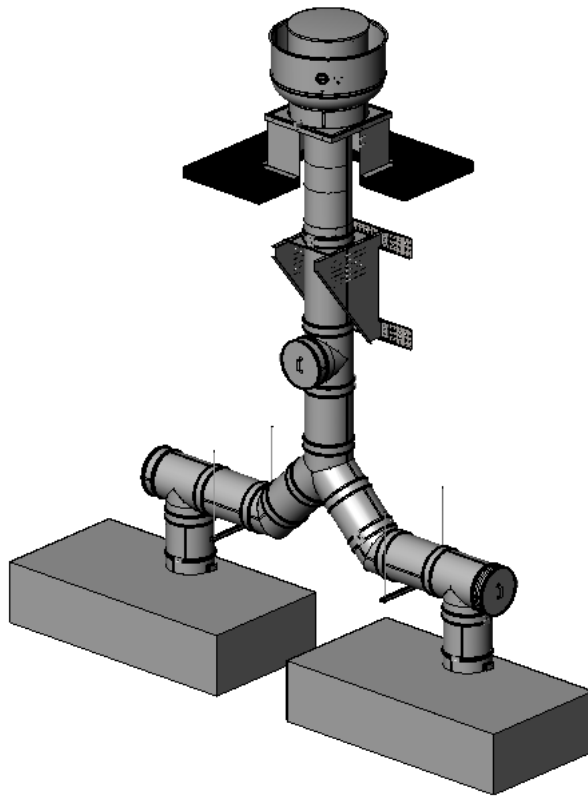

FOR YOUR SAFETY

TWO MAJOR CAUSES OF GREASE DUCT RELATED FIRES: (1) FAILURE TO MAINTAIN REQUIRED CLEARANCE (AIR SPACE) TO COMBUSTIBLE MATERIALS AND (2) FAILURE TO CLEAN GREASE LADEN DUCTS. IT IS OF UTMOST IMPORTANCE THAT THIS GREASE DUCT BE INSTALLED ONLY IN ACCORDANCE WITH THESE INSTRUCTIONS. DO NOT INSTALL GREASE DUCT WITHOUT FIRST READING THESE INSTRUCTIONS VERY CAREFULLY.

This grease duct is ETL listed to standards UL1978 / UL2221 / ASTM E2336 and AC101, grease duct installed per these instructions meets the requirements of NFPA 96.

Grease duct installed in accordance with these installation instructions will comply with national safety standards and building codes.

TABLE OF CONTENTS

WARRANTY.....	3
LISTINGS.....	4
CLASSIFICATIONS.....	4
APPLICATION.....	4
CLEARANCES.....	5
MECHANICAL.....	6
Joint Sealant.....	6
Sealant Features.....	6
Table 2 – Sealant Usage Chart.....	6
Grease Duct Joint Assembly.....	7
Adjustable Duct & Transition Connection.....	8
Adjustable Duct Standard Installation.....	9
Risers – Factory & Field (Bolted) Risers.....	11
Duct Drains.....	12
Manifold Tee.....	12
Access Door (Tee Cap) Assembly.....	13
Fan Adapter Plate.....	14
Prevention of Grease Accumulation in Horizontal Grease Duct.....	14
Alignment & Bracing of Grease Duct.....	14
Horizontal Support & Support Spacing.....	14
Vertical Support & Vertical Support Spacing.....	16
Through Penetration & Fire Stops.....	21
Annular Distance.....	21
Floor & Ceiling Fire Stop Installation.....	22
Wall Fire Stop Installation.....	23
Grease Duct Assembly Examples.....	24
METHODS USED TO TEST DUCT AFTER ASSEMBLY.....	27
Method 1 – Light Test per IMC 506.3.3.1.....	27
Method 2 – Smoke Test.....	27
GENERAL DUCT WEIGHTS.....	27
Weight – DW-2R.....	27
Weight – DW-3R.....	27
Weight – DW-3Z.....	27
Weight – Example.....	27
CLEANING & MAINTENANCE RECORD.....	28

WARRANTY

This ductwork system is warranted to be free from defects in material and workmanship, under normal use and service, for a period of 12 months from the date of shipment. This warranty shall not apply if:

1. The equipment is not installed by a qualified installer per the MANUFACTURER'S installation instructions shipped with this product (this guide should be kept with the equipment once installation is complete),
2. The equipment is not installed in accordance with federal, state and local codes and regulations.
3. The equipment is misused or neglected.
4. The equipment is not operated within its published capacity.
5. The invoice is not paid within the terms of the sales agreement.

The MANUFACTURER shall not be liable for incidental and consequential losses and damages potentially attributable to malfunctioning equipment. Should any part of the equipment prove to be defective in material or workmanship within the 12-month warranty period, upon examination by the MANUFACTURER, such parts will be repaired or replaced by the MANUFACTURER at no charge. The BUYER shall pay all labor costs incurred in connection with such repair or replacement. Equipment shall not be returned without MANUFACTURER'S prior authorization and all returned equipment shall be shipped by the BUYER, freight prepaid to a destination determined by the MANUFACTURER.

LISTINGS

This grease duct has been tested and is listed to UL1978 and UL2221 and testing has been extended to recognize ASTM E2336 and AC101 due to similar testing criteria. Models 2R, 3R and 3Z are used for grease duct applications when installed in accordance with these instructions and National Fire Protection Association "NFPA 96"; Standard for Ventilation Control and Fire Protection of Commercial Cooking Operations.

CLASSIFICATIONS

UL 2221: Standard for Fire Resistive Grease Duct Enclosure Assemblies. Chapter 7 of this standard references a test labeled Internal Fire Test. Section 7.1.1 references two installation conditions, Condition A and Condition B. Condition A represents all installation conditions except for installation within non-ventilated combustible enclosures. Condition B represents installation within a non-ventilated combustible enclosure.

Model 3Z is classified under UL2221 (Test of Fire Resistive Duct Enclosure Assemblies) as an alternate to 2-Hr. fire resistive shaft enclosures with a minimum zero clearance to combustibles (sizes 8" to 24" diameter). Model 3Z is listed in accordance with the requirements for duct enclosure Condition A and B.

Model 3R is classified under UL2221 (Test of Fire Resistive Duct Enclosure Assemblies) as an alternate to 2-Hr. fire resistive shaft enclosures with a reduced clearance to combustibles (sizes 8" to 24" diameter). Model 3R is listed in accordance with the requirements for duct enclosure Condition B.

Model 2R is classified under UL2221 (Test of Fire Resistive Duct Enclosure Assemblies) as an alternate to 2-Hr. fire resistive shaft enclosures with a reduced clearance to combustibles (sizes 8" to 16" diameter). Model 2R is listed in accordance with the requirements for duct enclosure Condition B.

APPLICATION

Double wall grease ducts are listed for a continuous internal temperature of 500°F and intermittent temperatures of 2000°F. Double wall grease duct is ideally suited for use in commercial cooking installations for the removal of smoke and grease laden vapors. Grease duct system size and capacity information may be obtained from the *ASHRAE Handbook – Fundamentals* or from the *Air Pollution Engineering Manual* of the US Environmental Protection Agency. Grease duct installations require provisions for cleaning the interior of the duct. NFPA 96 cleanout requirements are as follows:

1. A cleanout must be provided at each change of direction, except where the entire length of duct can be inspected and cleaned from either the hood or the discharge end.
2. On horizontal duct runs, at least one (1) 20" diameter opening must be provided. Where the opening is smaller than 20" diameter, openings large enough to permit cleaning must be provided at intervals of no more than 12'.
3. Openings must be at the side or the top, whichever is more accessible. When the opening is on the side of the duct, the lower edge of the opening must be at least 1 ½" above the bottom of the duct. For the listed grease duct, this is accomplished by the use of the grease manifold tee and cleanout cap.
4. On vertical duct runs where personnel entry is possible, access must be from the top of the riser. Where entry is not possible, access must be provided at each floor.

NOTE: ACCESS REQUIREMENTS ARE SUBJECT TO CHANGE IN ACCORDANCE WITH LOCAL CODE. LOCAL AUTHORITIES SHOULD BE CONSULTED FOR EXACT REQUIREMENTS. GREASE DUCT MAY BE CONNECTED ONLY TO HOODS IN A SINGLE FIRE ZONE ON ONE FLOOR. DO NOT CONNECT GREASE DUCTS TO ANY OTHER PART OF THE BUILDING VENTILATION OR EXHAUST SYSTEM.

When grease duct is installed in accordance with these installation instructions and the joints are sealed properly with the recommended sealant, the system will contain a grease fire within the duct. A grease fire can burn at extremely high temperatures. This system should be dismantled and inspected after any exposure to a grease fire. Any section that is distorted or discolored should be replaced. All joints in the system should be examined. The sealant expands to ensure a positive seal in the case of a fire, and any sealant that has been exposed to high temperature must be replaced. This will ensure that the system maintains its integrity against fire conditions in the future. The manufacturer of this grease duct cannot be responsible for grease duct systems that are not properly maintained or have been subjected to one or more grease fires.

CLEARANCES

In all buildings more than one story in height and in buildings where the roof-ceiling assembly is required to have a fire resistance rating, the duct must be enclosed in a continuous enclosure from the lowest fire-rated ceiling or floor above the hood, through any concealed spaces, to or through the roof to maintain the integrity of the fire separations required by the applicable building code provisions. If the building is less than 4 stories in height, the enclosure shall have a fire resistance rating of not less than 1 hour. If the building is 4 stories or more in height, the enclosure shall have a fire resistance rating of not less than 2 hours. Single wall grease duct is primarily intended for use in non-combustible surroundings. When installed in an open room where enclosure is not required, double wall grease duct may be located at clearance to combustibles in accordance with Table 1.

Table 1 – Grease Duct Clearances

DUCT MODEL	INNER DIAMETER (ID)	OUTSIDE DIAMETER	CLEARANCE TO COMBUSTIBLES	CLEARANCE TO NON-COMBUSTIBLES
DW	8" - 24"	= ID	18"	0"
DW - 2R	8" - 16"	ID + 4	3/4"	0"
DW - 3R	8" - 24"	ID + 6	3/4"	0"
DW - 3Z	8" - 24"	ID + 6	0"	0"

The above figures represent air space, in inches, to surrounding.

NOTE: See NFPA 96, 2004 EDITION, Chapter 3, Definition of Combustible, Limited Combustible and Non-Combustible.

*DW – 2R: 3/4" clearance to combustibles from the surface of the duct outer shell; zero inch clearance from combustibles from the tip of the outer V Band.

**DW – 3R: 3/4" clearance to combustibles from the surface of the duct outer shell; zero inch clearance from combustibles from the tip of the outer V Band.

NOTE: Double wall duct systems with reduced clearance "R" have been tested using Condition B – installed within non-ventilated combustible enclosure. See Fig. 1 below for representation of reduced clearance note, the V Band may be in contact with a combustible surface.

Fig.1 – Reduced Clearance

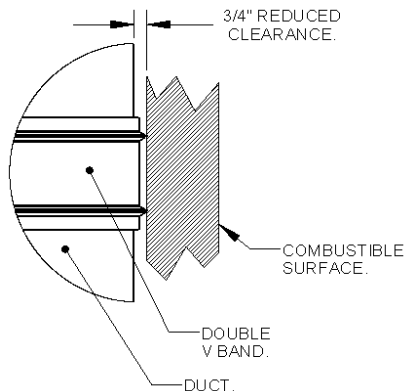

MECHANICAL

Joint Sealant

The joint sealant used to seal all joint assemblies is a 3M product. 3M Fire Barrier 2000+ Silicone Sealant is a ready-to-use, gun-grade, one-component silicone elastomer that cures upon exposure to atmospheric humidity to form a flexible seal. 3M Fire Barrier 2000+ Silicone Sealant, when installed properly, will control the spread of fire before, during and after exposure to open flames. It will stop the spread of noxious gas, smoke and water, and maintain the integrity of fire rated assemblies and construction. All grease ducts must be liquid tight per NFPA 96. The following steps are to be used to ensure that this requirement is met.

NO SEALANT SUBSTITUTES MAY BE USED.

Sealant Features

1. Superior adhesion.
2. Capable of withstanding 2000°F + temperatures.
3. Class 25 sealant, per ASTM 920.
4. Re-enterable/repairable.
5. Provides up to 4-hours fire-rating.
6. Cures upon exposure to atmospheric humidity.
7. Working time 30 minutes.
8. Cure time 14 to 21 days.
9. Applied with a standard caulk gun.

Table 2 – Sealant Usage Chart

3M FIRE BARRIER 2000 PLUS USAGE			
DIAMETER	DUCT PERIMETER FT	AVERAGE FEET PER TUBE	NUMBER OF JOINTS PER TUBE
8"	2.16	30	7
10"	2.68	30	6
12"	3.21	30	5
14"	3.73	30	4
16"	4.25	30	3.5
18"	4.78	30	3
20"	5.30	30	3
24"	6.35	30	2.5

Grease Duct Joint Assembly

All grease ducts are to be liquid tight per NFPA 96. The following steps are to be used to ensure that this requirement is met.

1. Fill the V band used with inner ductwork with 3M Fire Barrier 2000+ Silicone. The bead should be continuous. See **Table 2**, for the number of joints per tube.
2. Place the loose V band over the duct flange. Apply a continuous bead of 2000+ Silicone $\frac{1}{4}$ " wide to the flange that will be joined.
3. Join the two flanged ends of the inner duct sections together and rotate slightly to ensure complete coverage of sealant on flanges.
4. Install the V band around the duct flanges making sure the flanges are located within the V band.
NOTE: Do not locate the V band hardware at the bottom side of a horizontal duct joint. Tap the outside of the V band while tightening V band hardware to make sure the flanges are aligned and have been pulled together. Secure the $\frac{1}{4}$ -20 hardware to 85 in-lbs.
5. Insulation must be minimum of 4 $\frac{1}{2}$ " wide, and the same type and number of layers as the base duct. Tightly pack and completely fill all voids between the inner duct and the outer shell.
6. Install the double V band ensuring the outer shell flanges are positively engaged in the V bands before tightening the $\frac{1}{4}$ -20 hardware to 85 in-lbs. The double V band can be sealed using 3M Fire Barrier 2000+ Silicone when being installed outside.

Fig. 2 – Joint Assembly

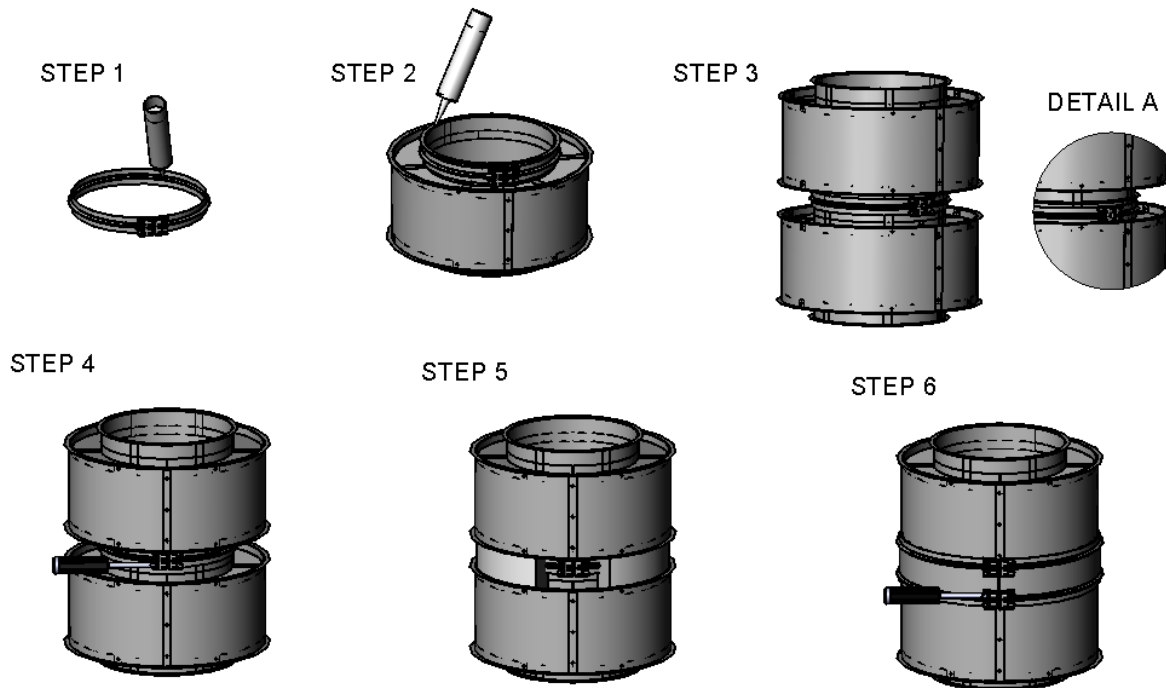

IMPORTANT: THE HARDWARE USED TO ASSEMBLE THIS DUCTWORK IS SPECIFICALLY DESIGNED FOR THIS APPLICATION. NO SUBSTITUTE HARDWARE IS ALLOWED. ALL REPLACEMENT HARDWARE MUST BE PURCHASED FROM THE FACTORY.

Adjustable Duct & Transition Connection

Adjustable duct sections may be used in conjunction with transition plates when they terminate at the fan. The adjustable duct section is fully welded to the transition plate, and then connected to the standard duct length using non-welded connections. Double wall adjustable duct sections are assembled in the field, as the exact length needed for the application is not known. Components for outer shell and insulation ship loose. Once fully assembled, the transition plate is secured to the curb using the method referenced in **Fig. 8 – Fan Adapter Plate**.

1. The standard duct section in the adjustable assembly is installed using the standard connection method, (see **Fig. 2**). Note: this is the piece with two flanges and the outer shell collar already attached 1 ½" from the duct flange.
2. Adjustable duct assemblies that are used with transition plates only have one inner duct flange protruding from the outer duct shell. This is the side that connects to the standard length duct.
3. The adjustable collar is slipped on to the adjustable duct section. Make sure the adjustable collar flanges are opposite the adjustable duct section flange.
4. The adjustable section is pushed inside the standard duct section. Make sure the minimum overlap is set correctly; see **Table 3**.
5. Once the overlap is set correctly, silicone the flanges of the bottom duct section and the adjustable collar using connection method referenced in **Fig. 2 – Joint Assembly** step 1 through step 3.
6. Adjustable collars are sealed to the adjustable duct using 3M Fire Barrier 2000+ Silicone. Once the V band has been installed, tighten the adjustable collar hardware to 85 in-lbs.
7. The insulation provided is used to wrap the adjustable assembly. Ensure all voids are adequately filled.
8. Cut the outer shell cover to the length and then install using the provided sheet metal screws. Make sure the shell cover overlaps and are secured to the shell collars. Use only hardware provided as longer screws may penetrate inner duct.
9. 3M Fire Barrier 2000+ Silicone may be used to seal the outer shell.

Fig. 3 – Adjustable Duct & Transition Plate

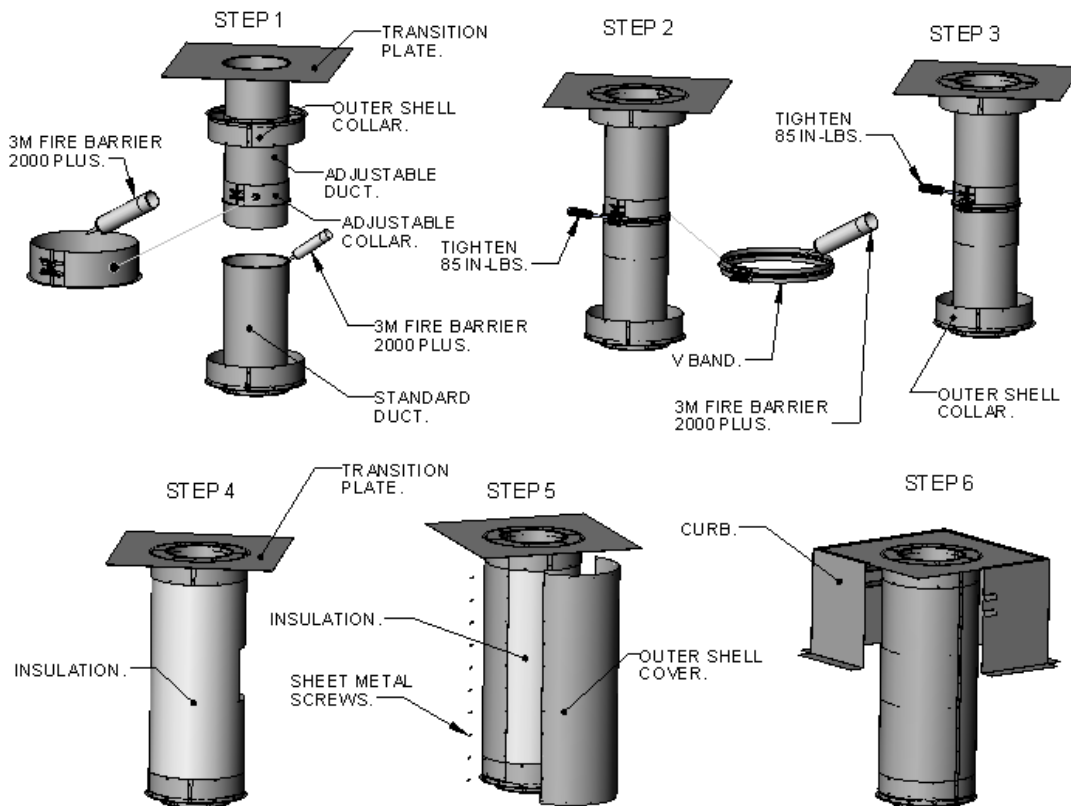

Adjustable Duct Standard Installation

Adjustable duct lengths are used to make up variable lengths in the duct system(s). Adjustable sections should always be installed with the overlap to the inside of the standard duct section. Overlap should always be opposite the direction of airflow. This will allow grease/water to run back to the hood when the system is shut down. If the inner adjustable section is too long to fit into the adjacent section of duct without interfering with the flow path it should be trimmed to the desired flange to flange length. Flange to flange length of adjustment can range from 4" to 26".

1. The standard duct section in the adjustable assembly is installed using the standard connection method, (see **Fig. 2**). Note: this is the piece with two flanges and the outer shell collar already attached 1 ½" from the duct flange.
2. The adjustable collar is slipped on to the adjustable duct section. Make sure the adjustable collar flanges are opposite the adjustable duct section flange.
3. The adjustable section is pushed inside the standard duct section. Make sure the minimum overlap is set correctly see **Table 3**.
4. Once the overlap is set correctly, silicone the flanges of the bottom duct section and the adjustable collar using connection method referenced in **Fig. 2** – Joint Assembly step 1 through step 3.
5. Adjustable collars are sealed to the adjustable duct using 3M Fire Barrier 2000+ Silicone. Once the V band has been installed, tighten the adjustable collar hardware to 85 in-lbs.
6. The insulation provided is used to wrap the adjustable assembly. Ensure all voids are adequately filled.
7. Cut the outer shell cover to the length and then install using the provided sheet metal screws. Make sure the shell cover overlaps and are secured to the shell collars. Use only hardware provided as longer screws may penetrate inner duct.
8. 3M Fire Barrier 2000+ Silicone may be used to seal the outer shell.

Table 3 – Minimum Overlap

DIAMETER	MIN OVERLAP FOR ADJUSTABLE DUCT
8"	4"
10"	5"
12"	6"
14"	6"
16"	6"
18"	6"
20"	6"
24"	6"

Fig. 3a – Adjustable Duct Overlap

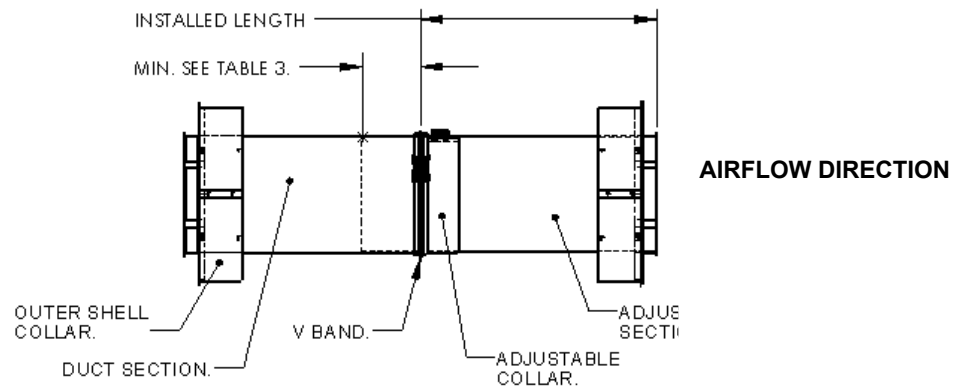
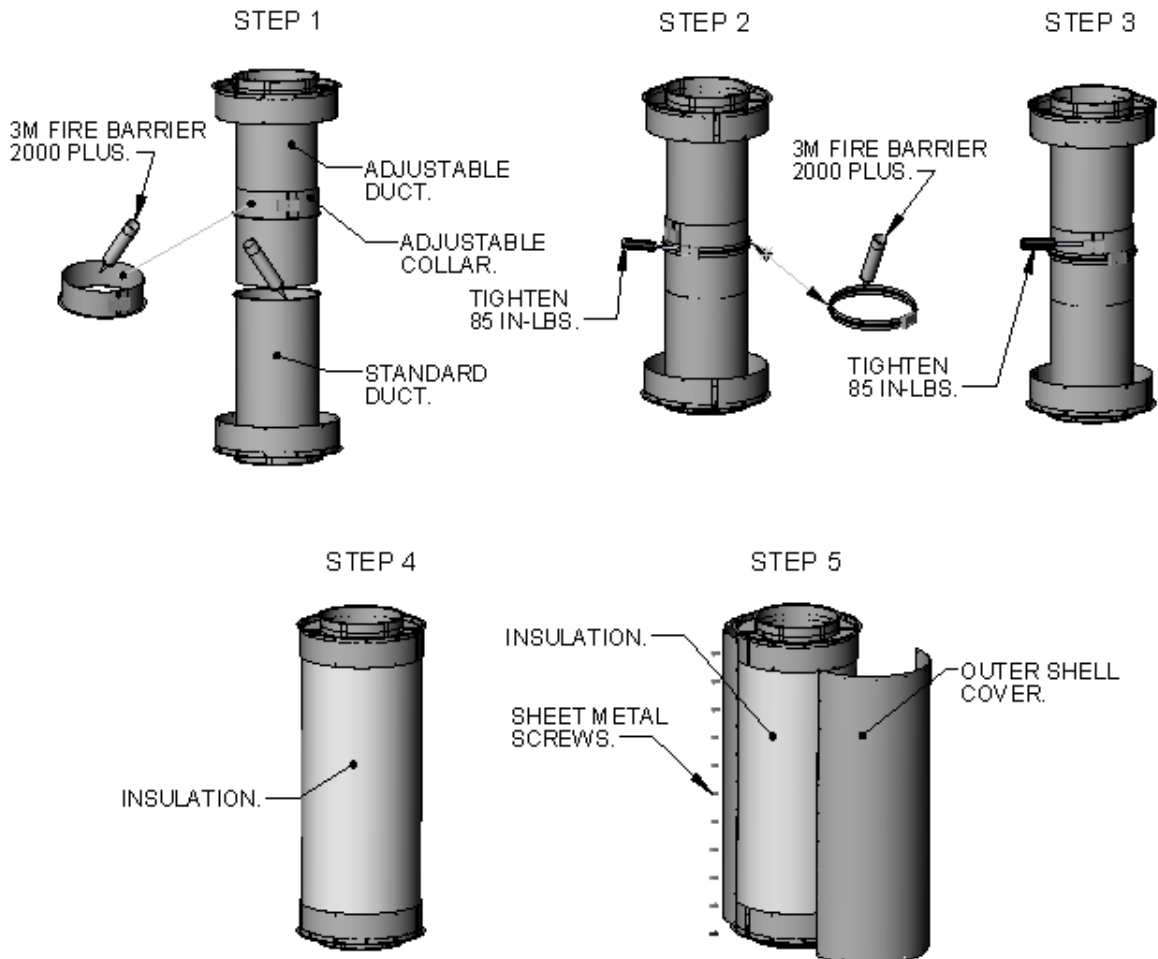

Fig. 3b – Collar & Adjustable Duct Installation



Risers – Factory & Field (Bolted) Risers

There are two options for the riser (connection to the hood plenum); factory welded and field bolted. Factory installed risers are welded to the plenum per instructions that detail riser size and location. The instruction below covers field installed (bolted) riser(s). When field installed riser(s) are requested, they ship loose allowing the installer to decide on the location. Field installed riser(s) are preferred when the exact location is not known or when adjustments need to be made for misalignment in duct systems.

1. Locate the specific position at which the riser needs to be installed.
2. Use the riser as a guide when marking the hood. Note: Make sure the hole location is inside the plenum area before cutting any holes.
3. Since the riser is going to be bolted to the plenum, a bolt hole circle will need to be cut. Use the bottom or loose retaining ring as a template. Align the inner circles of the hole in the plenum with the retaining ring and mark the bolt hole circle. Make sure the bolt hole circle is inside the plenum area before cutting.
4. Use the 3M Fire Barrier 2000+ Silicone to seal around the riser hole. Apply sealant to the top and bottom of the hole. Make sure the silicone bead is a minimum of ¼" thick and is continuous inside and outside of the bolt hole circle.
5. Center the riser over the hole in the plenum and push down. Make sure the riser flange is positively sealed. Also, make sure the captured retaining ring on the riser is pushed down into the sealant.
6. Align the loose retaining ring with the hole on the inside of the plenum. Push the ring up into the sealant. Align the holes in the bottom and top retaining rings and secure using ¼-20 hardware.
7. Place the loose duct flange ring over the riser before installing the connecting duct section using connection method (see **Fig. 2** – Joint Assembly, step 1 through step 3).
8. Once the riser and connecting duct section(s) have been connected, install the insulation provided. Make sure all voids are filled.
9. Install the riser covers by pushing the two halves together around the duct flange ring and securing it using sheet metal screws provided. Use only hardware provided, as longer screws may penetrate the inner duct.
10. See **Fig. 2** – Joint Assembly, step 1 through step 3, to install standard duct sections to factory installed or welded risers.
11. The slots in the riser covers provide an opening for the installation of duct sensors if required.

Fig. 4 – Field Installed Riser – Bolted

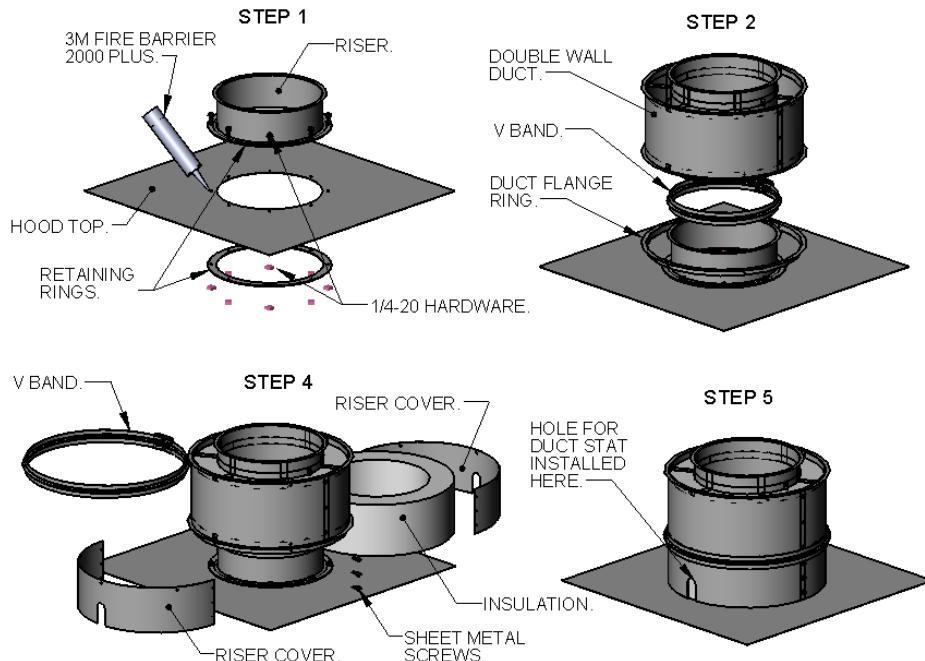

Duct Drains

Drains are used to provide a point at which low points in the duct system can be drained. Condensation and low lying water left over from duct cleaning can be drained easily with the installation of the ball valve drain. Drains are designed to aid in duct cleaning and can be used to drain grease into an approved grease collection reservoir. Drains are offered in two different sizes: 1 and 1-1/2 inch. The 1-inch drain is used on 8" through 14" diameter duct and the 1-1/2 inch drain is used on the 16" through 24" diameter duct (see Fig. 5. for details).

Fig. 5 – Duct Drain

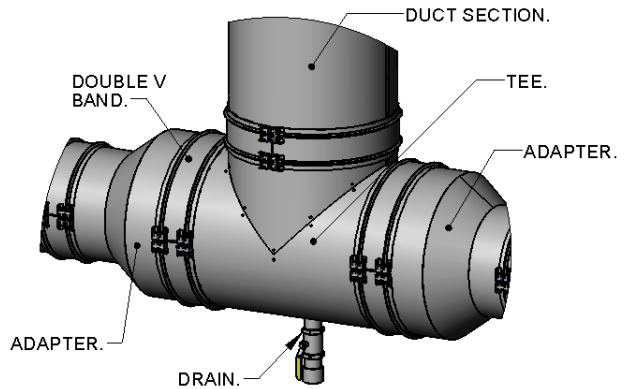

Manifold Tee

The manifold tee is used to provide access for cleanout to comply with NFPA 96 requirements. It is equipped with an internal blank that acts as a grease dam and gasket. The access port is then closed with a cleanout cap or tee cap. The tee cap is then covered with layers of insulation that is covered in an outer shell called the access door collar. The location of the access port in the tee is dependent on the orientation of the tee in the final installation. The access port location in the manifold tee can be orientated as required (see Fig. 6). Access ports should never be located where grease can build up and fall out once the cleanout cap is removed or where the access door collar cannot be removed to gain access to the inner duct.

Fig. 6 - Manifold Tee Position

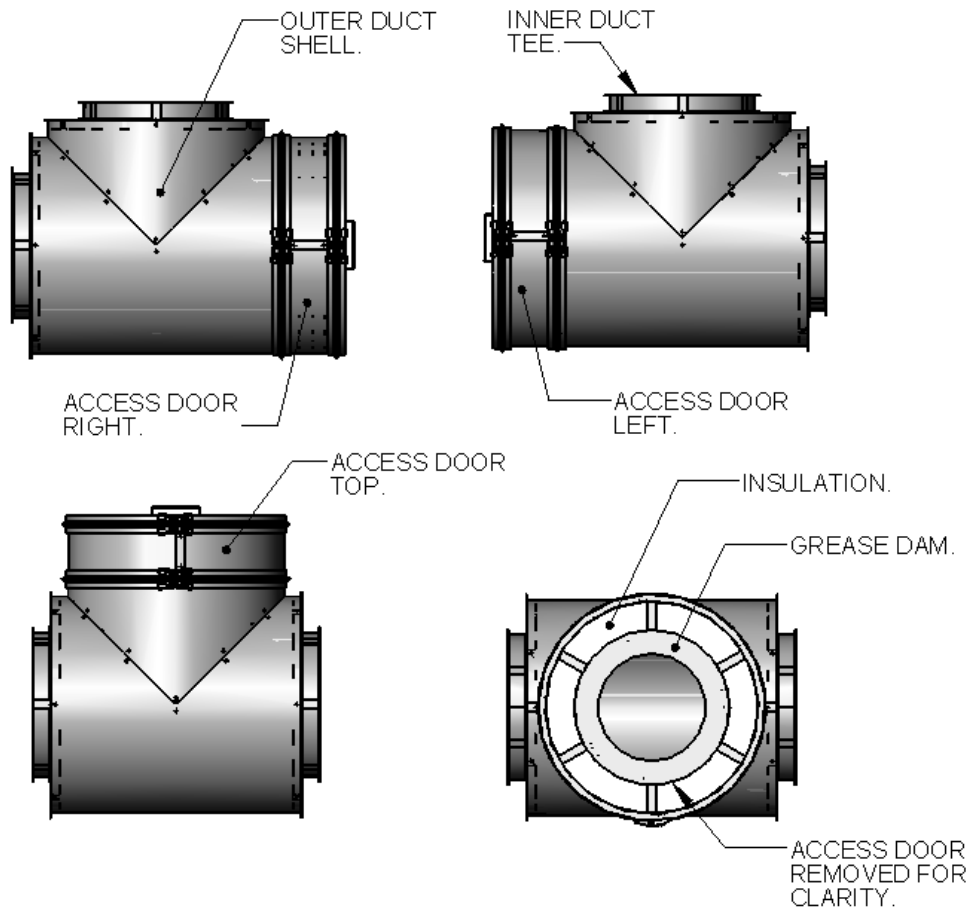

Access Door (Tee Cap) Assembly

Access doors (tee caps) are available in diameters from 8" to 24". They work in conjunction with the manifold tee as previously shown in **Fig. 6**. The tee joint connection is shown in **Fig. 2 – JOINT ASSEMBLY**; however, the installation of the access door is slightly different so read the following instructions very carefully. Consult NFPA 96, Chapter 7, Section 7.3.1 "Openings shall be provided at the sides or at the top of the duct, whichever is more accessible, and at change of directions."

1. Select the location and the position of the access door.
2. All tee joints will be connected as shown in **Fig. 2 – JOINT ASSEMBLY** except for the access door.
3. Apply a ¼" continuous bead of 3M Fire Barrier 2000+ silicone to the flange of the tee that will be used for access to the duct system.
4. Center the inside blank (grease dam) over the opening of the tee and apply pressure. Make sure the grease dam is sealed to the tee flanges.
5. Apply enough pressure to create a positive bond between the tee flange and the grease dam. Remove excess sealant after making parts concentric (centered).
6. Sealant will begin to cure upon exposure to atmospheric humidity. It will form a flexible seal.
7. Once the sealant is dry attach the access door using a V band. Ensure flanges are in the V before tightening ¼-20 hardware to 85 in-lbs.
8. Once the inner access door assembly is complete install the outer access door or access door collar.
9. The outer access door collar is used to seal the inner access door with insulation, (see **Fig. 7** below).

Fig. 7 – Access Door Assembly

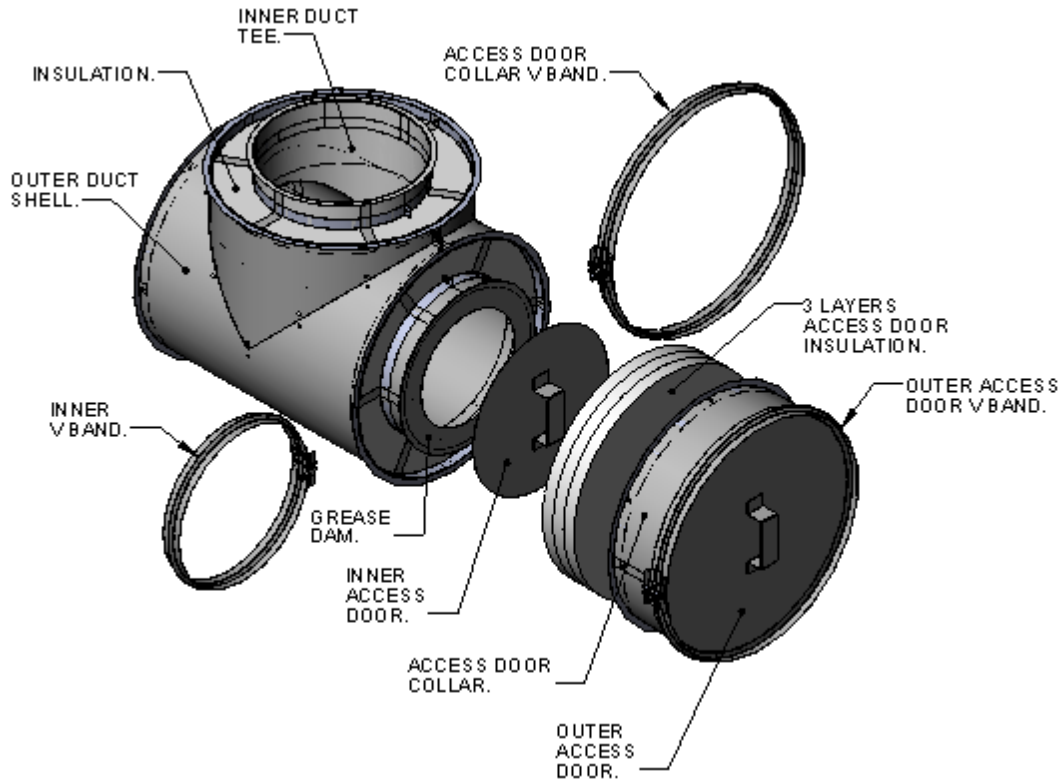

Fan Adapter Plate

The fan adapter plate (Transition Plate) is designed to connect to a roof curb. The duct section is welded to the underside of the adapter plate. The adapter plate is formed to provide a slope to allow grease deposits to flow back towards the duct. When connected (see Fig. 8), the plate mounts on top of the fan curb that supports the fan housing. The plate may be positioned off center within the curb provided that the minimum distance to combustibles is maintained. In the event that the plate is positioned off center, trim off excess plate material to allow for fan placement. Secure the plate to the curb using a minimum of three fasteners per side. A suitably sized fastener provided by others is used. The fan adapter plate can be used to maintain distance to combustibles and also for vertical support. See Fig. 3 for adjustable duct section assembly. The top collar is installed upside down to seal the insulation at the fan termination / transition plate.

Fig. 8 – Fan Adapter Plate

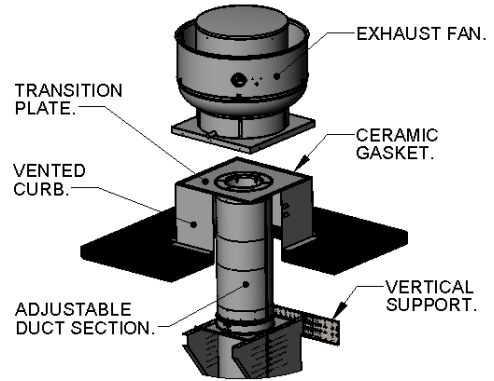

Prevention of Grease Accumulation in Horizontal Grease Duct

In some areas the local code authority may insist on inclusion of 1/4" per foot slope. In such cases, a short "Slope Transition" section is available from the factory. For correct installation, two slope transitions are generally required - one at the beginning and end of the horizontal duct run. For installations with horizontal runs greater than 75 feet, some local codes demand a 1/2" per foot slope. Consult with local code authorities if unsure about local requirements. Offset collars have been designed to meet the above specification. The collar is used in conjunction with other accessories such as tee's and elbows to maintain the above listed slope in horizontal duct runs.

Alignment & Bracing of Grease Duct

Grease duct has the characteristics of a continuous stainless steel pipe and it will expand and contract along its entire length with changes in temperature. For this reason, conventional methods of attaching guides and braces to the outer wall of the grease duct cannot be used. Correctly installed support rings, saddles and wall guide assemblies will serve to keep the duct aligned, provide for adequate resistance to lateral loads and allow the free axial expansion and contraction movement. A simplified rule for duct expansion is that the axial growth will be approximately 1 inch per 100 feet of pipe length for each 100 degrees Fahrenheit the exhaust vapor temperature is above the surrounding air temperature.

Horizontal Support & Support Spacing

Horizontal duct runs are supported using either 2 X 2 X 1/8" angle or Uni-strut. Horizontal support spacing is shown in Table 4. When cutting the angle or Uni-strut to length, there must be a minimum of 2" on either side of the duct shell to allow for rod attachment. Once the angle has been cut to length it is suspended using 1/2" threaded rod (minimum). Appropriate sized holes are drilled / punched in either end of the angle. The 1/2" threaded rod is secured to the angle or Uni-strut using 1/2" grade 5 hex nuts and 1/2" hardened washers, see Fig. 9. Note: double hex nuts are used as locking nuts to make sure hardware does not come loose over time.

Table 4 – Horizontal Support Spacing

DIAMETER	HORIZONTAL SUPPORT SPACING (FEET)
8"	7'
10"	7'
12"	7'
14"	7'
16"	7'
18"	5'
20"	5'
24"	5'

Fig. 9 – Horizontal Support Details

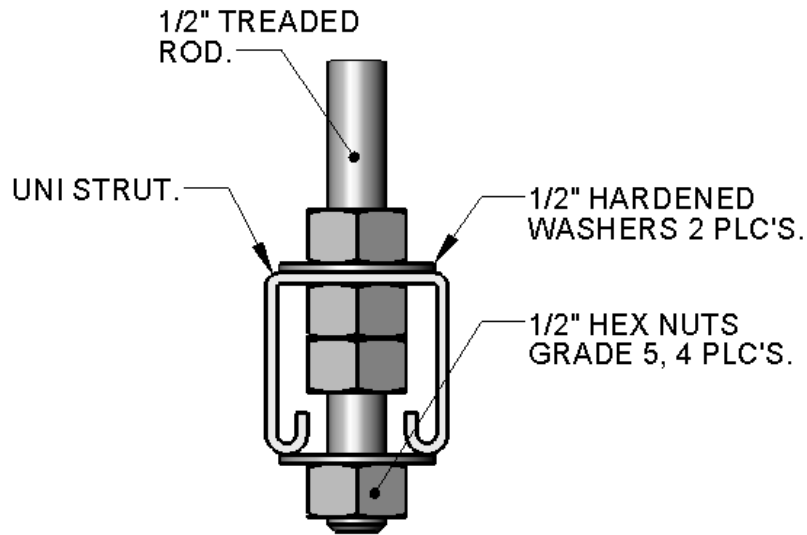
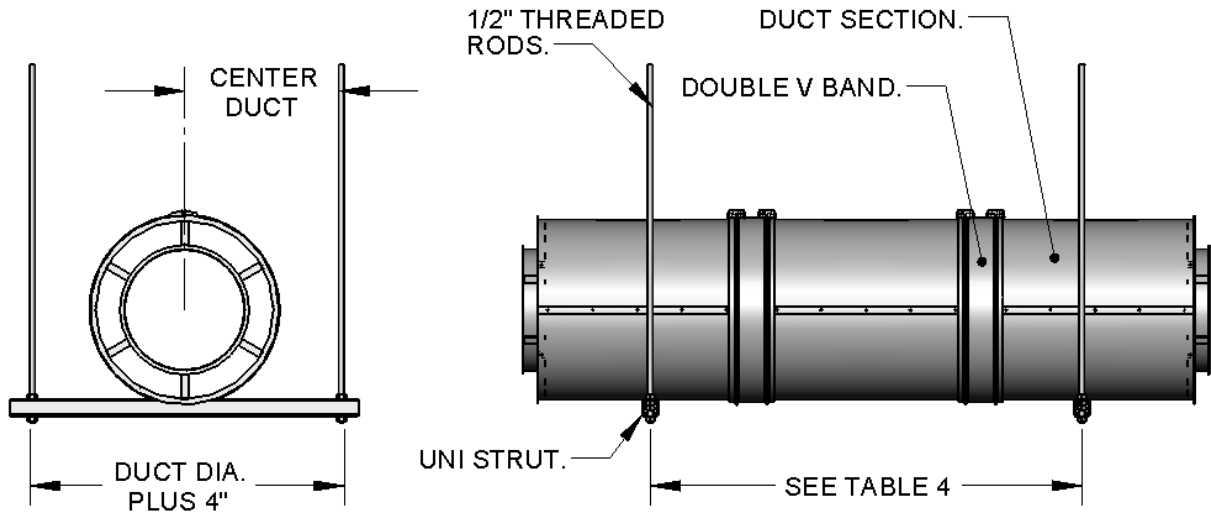

Vertical Support & Vertical Support Spacing

This duct system requires supports along vertical runs. The vertical support (DWXXDWVESU) assembly kit consist of (2) wall support plates, (2) side support plates, (2) flat support plates (specific to shell diameter) and hardware. There are three different types of hardware supplied depending on the type of wall that the duct is being supported. There are three types of wall construction listed below; gypsum with wooden studs, gypsum with 25 gauge steel studs and concrete/masonry. Each wall construction type requires different hardware to be used when installing the wall support and side support plate. Maximum vertical support spacing is shown in **Table 5**. Do not exceed this listed vertical spacing.

Table 5 – Vertical Support Spacing

DIAMETER	VERTICAL SUPPORT SPACING (FEET)
8"	10'
10"	10'
12"	10'
14"	10'
16"	10'
18"	10'
20"	10'
24"	10'

Fig. 10 – Vertical Support Kit

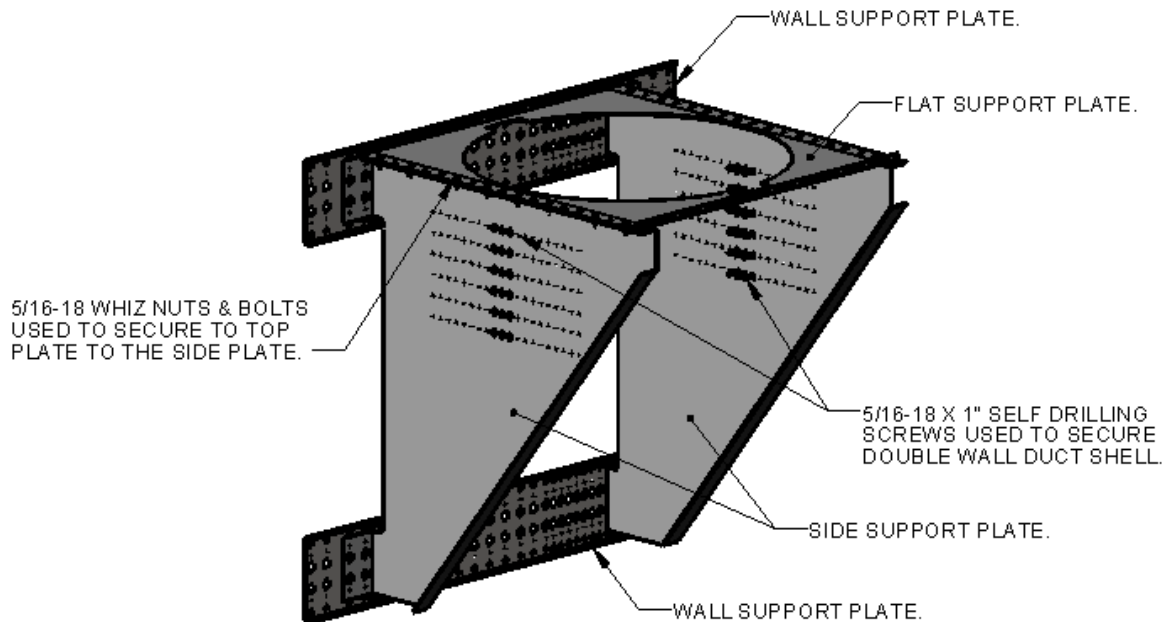
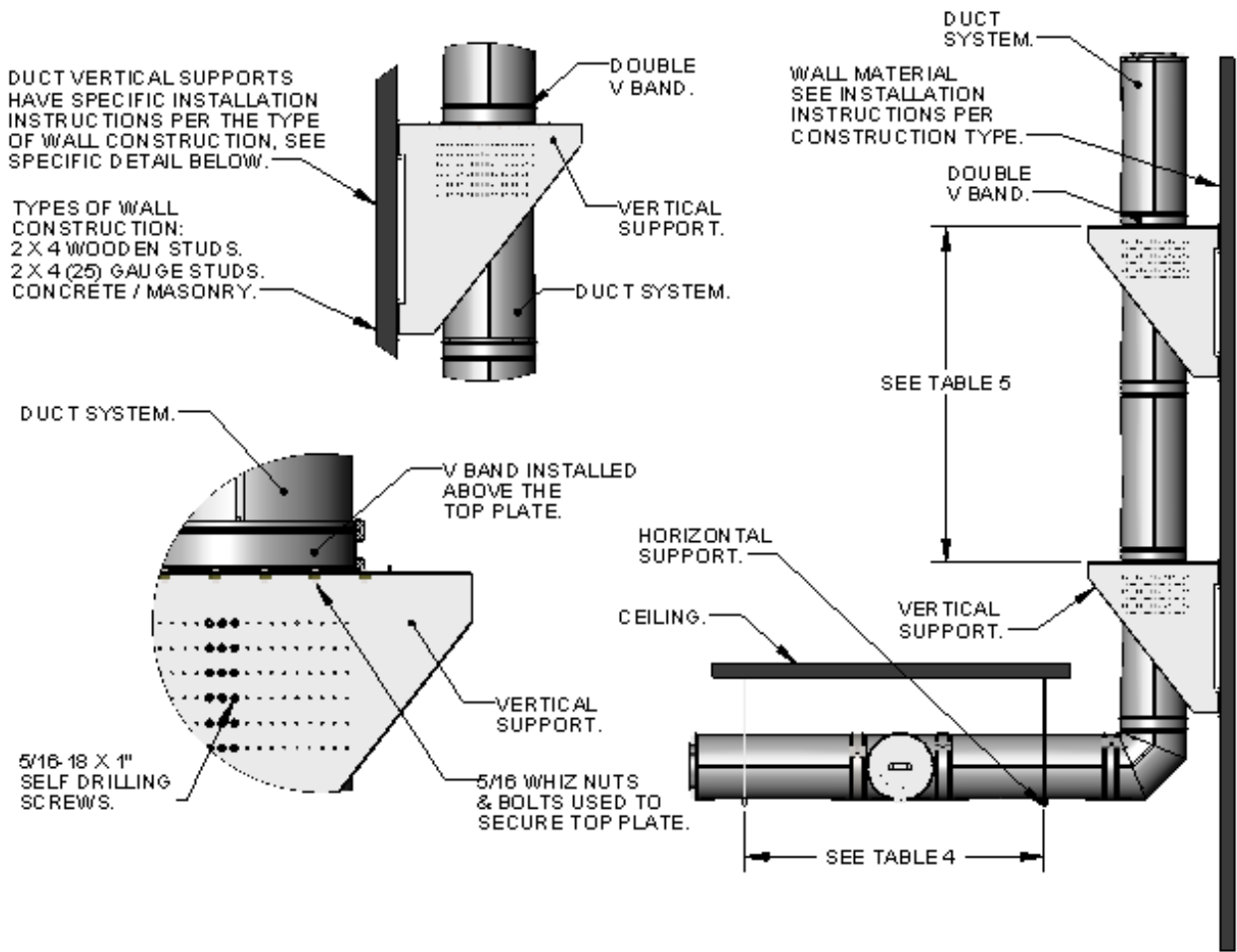

Fig. 10a – Vertical Support Details



Vertical Support For Wooden Wall Construction

1. Wall must be constructed of 2 x 4 wooden studs with a max spacing of 24 inches on center and covered with 5/8 inch gypsum.
2. Install the top wall support plate so that the flat support plates, when installed, will be under the duct v-band. See **Fig 10a** for details.
3. The wall support plate has specific holes that locate the side plates so that when installed, they match the duct outer shell diameter. Measure the duct diameter and then measure from the wall plate center holes the radius to locate the first side plate. Example: if the duct being installed has a 30 inch outside shell, measure from the center of the wall plate 15 inches. This will locate the inside of the side plate on the wall plate. Side support plate mounting holes should be on the outside.
4. Once the first wall support plate is located, secure to the wall using the 5/16 x 4 inch toggle bolts and washers. Use the 7/8 inch holes that are 24 inches on center from the side plate mounting holes. In some cases, mounting holes may have to be drilled to align with studs.
5. Follow the instructions above and mount the second wall support plate. Measurement will be 44 inches from the top of the first wall support to the bottom of the second wall support.
6. Install the side support plates. Measure from center and locate the first plate. One of the side plates must be installed using 5/16 x 3 1/2 inch lag bolts and washers directly into the 2 x 4 wooden stud. Fill all holes using the lag bolts and washer that line up with the stud. Lag bolts will secure the wall plates and side plates to the studs.
7. Measure 24 inches from the first stud that the side plate is secured to and install 5/16 x 3 1/2 inch lag bolts and washers. This will secure the wall support plate to the stud 24 inches on center.
8. Measure from center and install the second side plate. This plate may fall between studs and if so, secure using the 5/16 x 4 inch toggle bolts and washers.
9. Repeat the above process so that both wall supports and side plates are installed and secure.
10. Install the rear flat support plate using 5/16 nuts and bolts. Mount the duct so the v band is above the flat support plate and secure by installing the front flat support plate.
11. The v band "V" should be sitting on top of the flat plate. A cut out is provided in the flat plate to allow the v band bracket to fall through so the "V" is flush with the flat support plate
12. Secure the side support left and right plates to the outer duct shell using the 5/16-18 x 1 inch self drilling screws. Use the guide holes to locate the shell center and fill all holes center, center left and center right. A minimum of 18 screws must be used on each side of the duct.

Figure 10B – Wooden Stud Wall Vertical Support

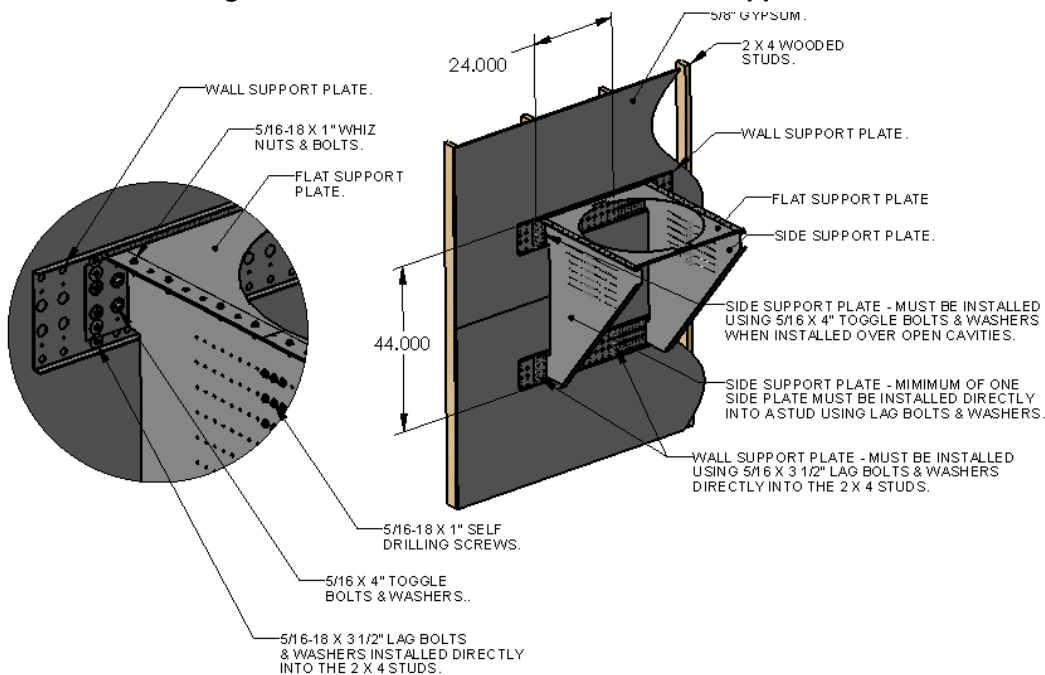

Vertical Support For 25 Gauge Steel Stud Wall Construction

1. Wall must be constructed of 2 x 4 25 gauge (minimum) steel studs with a max spacing of 24 inches on center and covered with 5/8 inch gypsum.
2. Install the top wall support plate so that the flat supports plates, when installed, will be under the duct v-band. See **Fig 10a** for details.
3. The wall support plate has specific holes that locate the side plates so that when installed, they match the duct outer shell diameter. Measure the duct diameter and then measure from the wall plate center holes the radius to locate the first side plate. Example: if the duct being installed has a 30 inch outside shell, measure from the center of the wall plate 15 inches. This will locate the inside of the side plate on the wall plate. Side support plate mounting holes should be on the outside.
4. Once the first wall support plate is located, secure to the wall using the 5/16 x 4 inch toggle bolts and washers. Use the 7/8 inch holes that are 24 inches on center from the side plate mounting holes. In some cases, mounting holes may have to be drilled to align with studs.
5. Follow the instructions above and mount the second wall support plate. Measurement will be 44 inches from the top of the first wall support to the bottom of the second wall support.
6. Install the side support plates. Measure from center and locate the first plate. One of the side plates must be installed using 5/16 x 1 1/2 self drilling screws and washers directly into the 2 x 4 metal studs. Fill all holes using the self drilling screws and washer that line up with the stud. Self drilling screws will secure the wall plates and side plates to the studs.
7. Measure 24 inches from the first stud that the side plate is secured to and install 5/16 x 1 1/2 inch self drilling screws and washers. This will secure the wall support plate to the stud 24 inches on center.
8. Measure from center and install the second side plate. This plate may fall between studs and if so, secure using the 5/16 x 4 inch toggle bolts and washers.
9. Repeat the above process so that both wall supports and side plates are installed and secure.
10. Install the rear flat support plate using 5/16 nuts and bolts. Mount the duct so the v band is above the flat support plate and secure by installing the front flat support plate.
11. The v band "V" should be sitting on top of the flat plate. A cut out is provided in the flat plate to allow the v band bracket to fall through so the "V" is flush with the flat support plate.
12. Secure the side support left and right plates to the outer duct shell using the 5/16-18 x 1 inch self drilling screws. Use the guide holes to locate the shell center and fill all holes center, center left and center right. A minimum of 18 screws must be used on each side of the duct.

Figure 10C – Steel Stud Wall Vertical Support

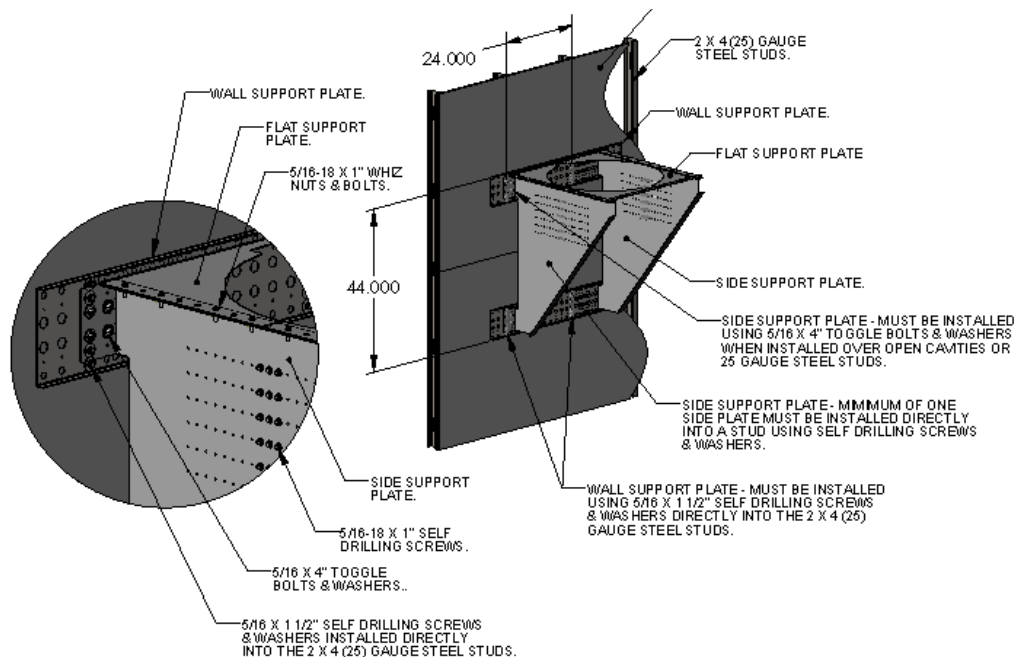

Vertical Support For Concrete/Masonry Wall Construction

1. These steps describe the method to attach the vertical support to a concrete and (or) masonry wall.
2. Install the top wall support plate so that the flat supports plates, when installed, will be under the duct v-band. See **Fig 10a** for details.
3. The wall support plate has specific holes that locate the side plates so that when installed, they match the duct outer shell diameter. Measure the duct diameter and then measure from the wall plate center holes the radius to locate the first side plate. Example: if the duct being installed has a 30 inch outside shell, measure from the center of the wall plate 15 inches. This will locate the inside of the side plate on the wall plate. Side support plate mounting holes should be on the outside.
4. Once the first wall support plate is located, secure to the wall using the 5/16 x 2 1/4 inch concrete/masonry screws and washers. Use the 7/8 inch holes that are 24 inches on center from the side plate mounting holes. Install 5/16 x 2 1/4 inch concrete/masonry screws in each end of the wall support plate. In some cases, mounting holes may need to be drilled.
5. Follow the instructions above and mount the second wall support plate. Measurement will be 44 inches from the top of the first wall support to the bottom of the second wall support.
6. Install the side support plates. Measure from center and locate the first plate. Fill all holes using the 5/16 x 2 1/4 inch concrete/masonry screws and washer. Concrete/masonry screws will secure the wall plates and side plates to the wall.
7. Measure 24 inches from the first set of holes in the side plate that is secured to the wall and install 5/16 x 2 1/4 inch concrete/masonry screws and washers. This will secure the wall support plate to the wall.
8. Measure from center and install the second side plate using 5/16 x 2 1/4 inch concrete/masonry screws and washers.
9. Repeat the above process so that both wall supports and side plates are installed and secure.
10. Install the rear flat support plate using 5/16 nuts and bolts. Mount the duct so the v band is above the flat support plate and secure by installing the front flat support plate.
11. The v band "V" should be sitting on top of the flat plate. A cut out is provided in the flat plate to allow the v band bracket to fall through so the "V" is flush with the flat support plate
12. Secure the side support left and right plates to the outer duct shell using the 5/16-18 x 1 inch self drilling screws. Use the guide holes to locate the shell center and fill all holes center, center left and center right. A minimum of 18 screws must be used on each side of the duct.

Figure 10D – Concrete/Masonry Wall Vertical Support

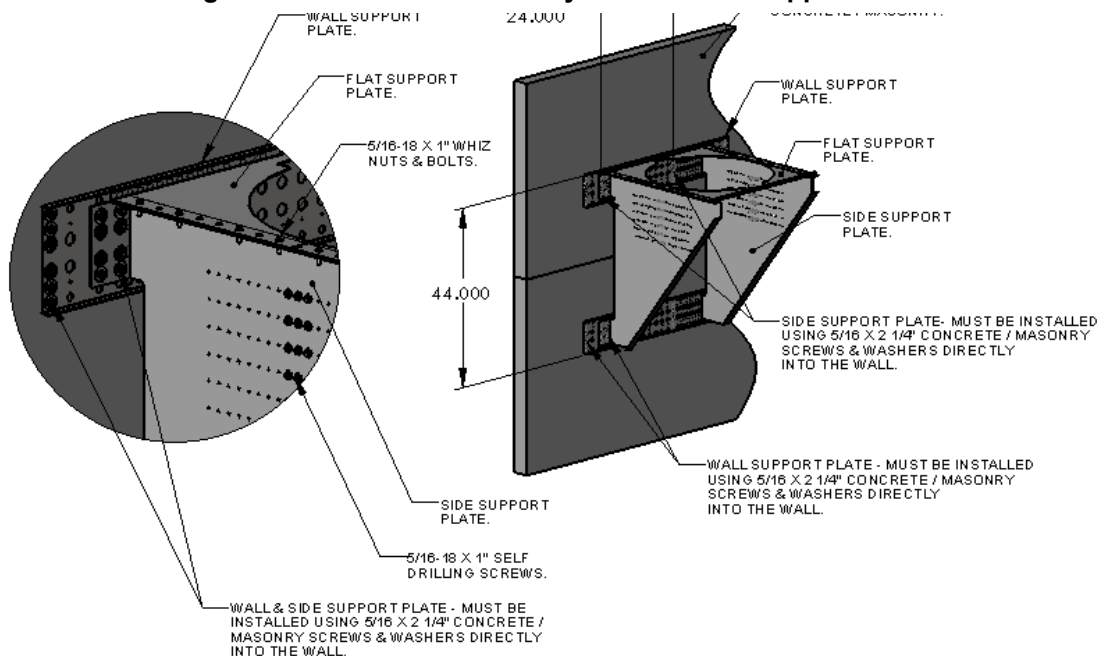

Through Penetration & Fire Stops

Through floor fire stop support assemblies are used to support duct sections that penetrate a fire resistant floor(s). The full support ring is installed under the double V band; the struts are connected to the support ring with supplied 5/16-18 hardware. Once the struts have been connected they are secured to the floor using appropriate type and size fasteners supplied by others. The fire stop support is designed to support the penetrating duct section and maintain annular distance, see **Fig. 10b** above for details.

When duct systems penetrate a fire resistance rated floor, ceiling and/or a wall, a fire stop kit is used to retain the fire resistance rating on the floor and/or wall. The double wall grease duct (2R, 3R and 3Z) and the fire stop assemblies detailed below have achieved 2-hour ratings for integrity, insulation and stability. Testing was conducted in accordance with the applicable requirements UL 2221, Test of Fire Resistive Grease Duct Enclosure Assemblies.

Table 6 – Opening Size Through Penetrations

DUCT MODEL	INNER DIAMETER	OUTER DIAMETER	SQUARE / ROUND OPENING MIN/MAX
DW - 2R	8"	12"	14" - 15"
DW - 2R	10"	14"	16" - 17"
DW - 2R	12"	16"	18" - 19"
DW - 2R	14"	18"	20" - 21"
DW - 2R	16"	20"	22" - 23"
DW - 3R / 3Z	8"	14"	16" - 17"
DW - 3R / 3Z	10"	16"	18" - 19"
DW - 3R / 3Z	12"	18"	20" - 21"
DW - 3R / 3Z	14"	20"	22" - 23"
DW - 3R / 3Z	16"	22"	24" - 25"
DW - 3R / 3Z	18"	24"	26" - 27"
DW - 3R / 3Z	20"	26"	28" - 29"
DW - 3R / 3Z	24"	30"	32" - 33"

Annular Distance

Grease duct is to be installed eccentrically or concentrically within the fire stop system. The annular space between the grease duct and the periphery of the opening shall be a minimum of 1" to a maximum of 2" for 1 and 2 hour fire rated floor and wall assemblies. Grease duct to be rigidly supported on both sides of the floor and or wall assembly. The F and T rating for the fire stop systems shown below are rated for 2 hours. The fire stop ratings are applicable only when Specified Technologies Series SSS Latex Intumescent (**STI Triple S**) Sealant is used. Annular distance is measured perpendicular from the outside of the grease duct to the periphery of the opening (see **Fig. 11** for details).

Fig. 11 – Annular Distance

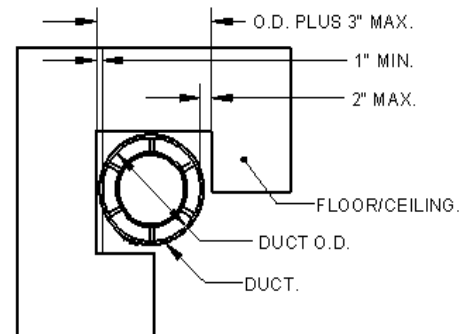

Floor & Ceiling Fire Stop Installation

1. Cut an opening in the floor/ceiling that is a minimum of 2" and maximum of 3" larger than the outside diameter of the duct being installed (see **Table 6**).
2. The grease duct can be installed eccentrically or concentrically within the opening. The distance from the outside of the grease duct to the periphery of the opening cannot exceed 2". 2" is the maximum annular distance allowed (see **Fig. 11**).
3. Apply a continuous ½" bead of STI Triple S intumescent around the fire plates. The fire plates are designed to fit around the duct and overlap by 1".
4. The fire plates are installed on the bottom side of the floor/ceiling. Push the plates up to the floor/ceiling so the intumescent seals the plates against the floor/ceiling. Then secure using ¼-20 x 1 ½" long concrete fasteners where the plates overlap, secure using ¼-20 x 1" sheet metal screws.
5. Seal the topside using the intumescent seal around the duct and fire plates. Seal the edge of the opening to the fire plates.
6. Fill the cavity using (4) layers of insulation, make sure that all voids are filled. The insulation is fully compressed into the opening until it is ¾" from the top of the opening.
7. Cover the compressed insulation with intumescent. Continue until the intumescent is level with the top of the opening. The intumescent should overlap on to the floor/ceiling, ensuring there are no gaps between the edges of the opening or the duct outer shell.
8. Wrap one layer of 1" x 12" provided insulation around the base of the duct and enclose with the half enclosure bands. The insulation and bands should be touching the intumescent, do not disturb or compromise the intumescent when installing. The enclosure bands are assembled using ¼-20 x ¾" hardware.
9. Install the vertical fire stop support; ensuring the full support ring is installed under the double V band. Once in place, the legs are secured to the floor/ceiling using appropriate type and size fasteners (see **Fig. 12** for details).

Fig. 12 – Floor & Ceiling Fire Stop Installation

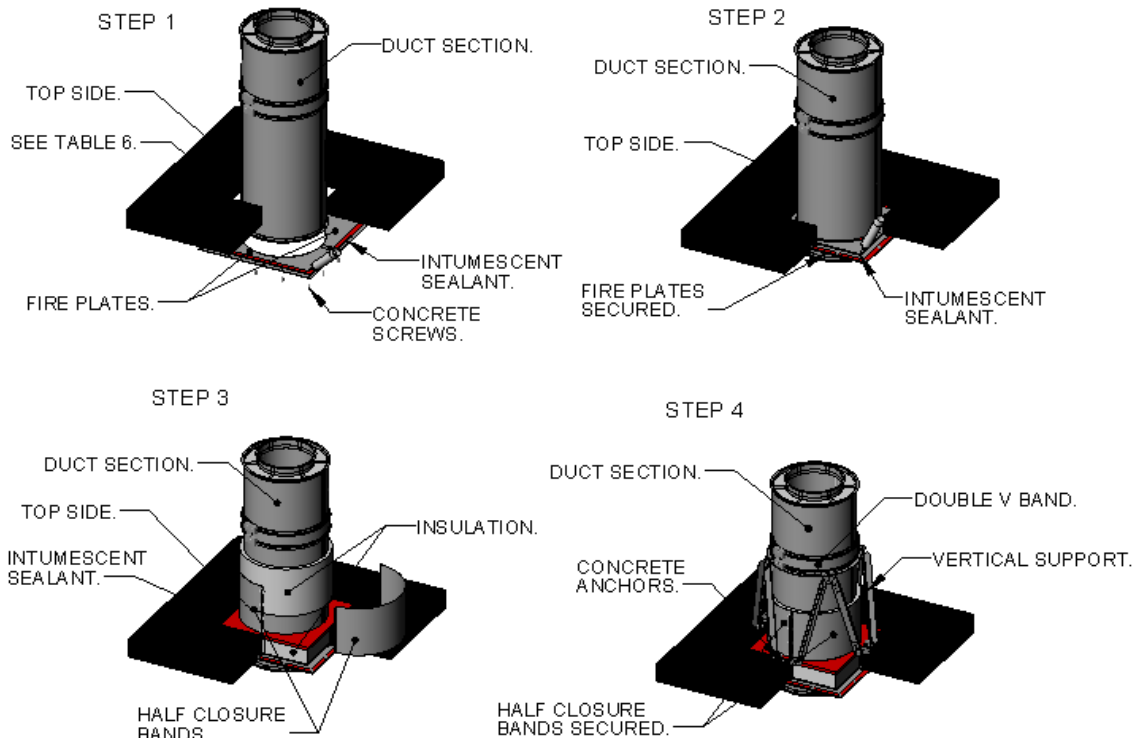

Wall Fire Stop Installation

1. Cut an opening in the wall that is a minimum of 2" and maximum of 3" larger than the outside diameter of the duct being installed. See **Table 6**.
2. The grease duct can be installed eccentrically or concentrically within the opening. The distance from the outside of the grease duct to the periphery of the opening cannot exceed 2". 2" is the maximum annular distance allowed; see **Fig. 11**.
3. Apply a continuous ½" bead of STI Triple S intumescent around the closure plates; the fire plates are designed to fit around the duct and overlap by 1".
4. The fire plates are installed on the backside of the wall. Push the plates up to the wall so the intumescent seals the plates against the wall. Then secure using ¼-20 x 1 ½" long concrete fasteners where the plates overlap secure using ¼-20 x 1" sheet metal screws.
5. Apply a ¾" covering of intumescent sealant to the inside of the fire plates installed on the backside of the wall. The sealant should be smooth and without any gaps on the edges of the opening or outside of duct.
6. Fill the cavity using the insulation provided, ensuring that all voids are filled. The insulation is fully compressed into the opening until it is ¾" from the edge of the opening in the wall.
7. Cover the compressed insulation with intumescent. Continue until the intumescent is flush with the edge of the wall opening. The intumescent should overlap on to the wall, ensuring there are no gaps between the edges of the opening or the duct outer shell.
8. Install the fire plates on the front side of the wall. Push the plates up to the wall so the intumescent seals the plates against the wall. Then secure using ¼-20 x 1 ½" long concrete fasteners where the plates overlap secure using ¼-20 x 1" sheet metal screws.
9. Wrap one layer of 1" x 12" provided insulation around the base of the duct and enclose with the half enclosure bands. The insulation and bands should be touching the intumescent. The enclosure bands are assembled using ¼-20 x 1" hardware. This is done on the front and back of the wall.
10. Horizontal supports are used to support the duct on either side of the wall. See **Fig. 9** for details.

Fig. 13 – Wall Fire Stop Installation

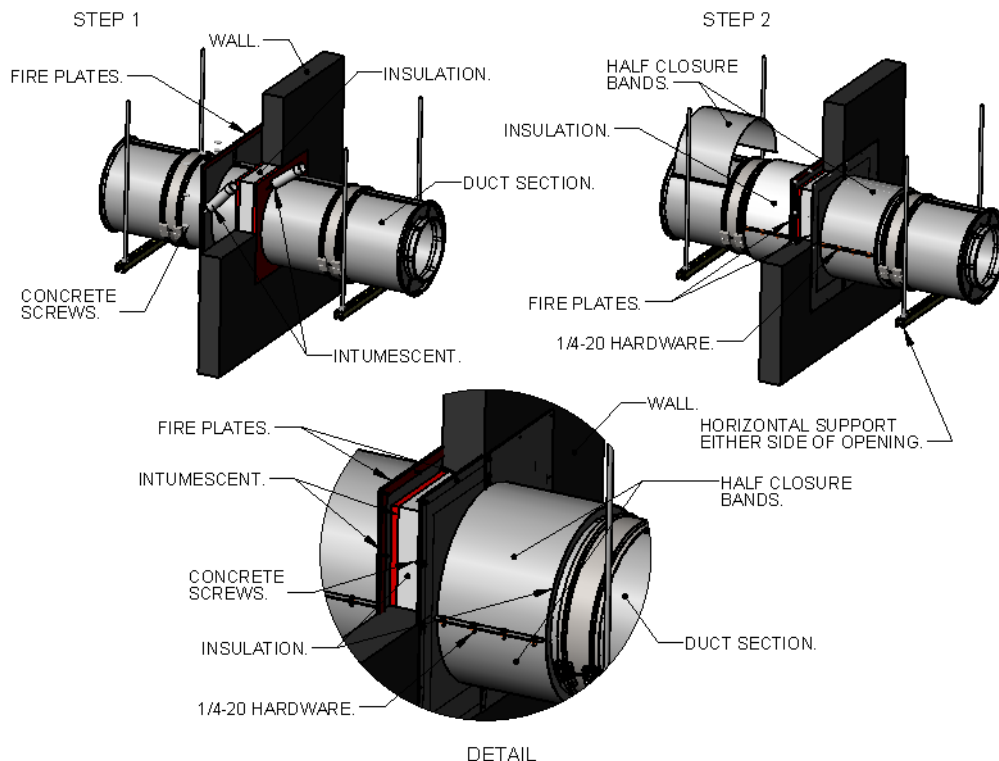

Grease Duct Installation:

The illustration shown provides useful information on the installation of grease duct systems. Each installation is specific to the application and the job site. If you encounter a situation not covered by this illustration, refer to the guide or consult the factory. The grease duct systems illustrated in this manual have been tested to and comply with UL 2221, Tests of Fire Resistant Grease Duct Enclosure Assemblies.

Grease Duct Assembly Examples

Fig. 14 - Grease Duct Installation Guide

Adjustable duct and standard ducts are used to terminate at the transition plate. The duct section is fully welded to the transition plate at the factory.

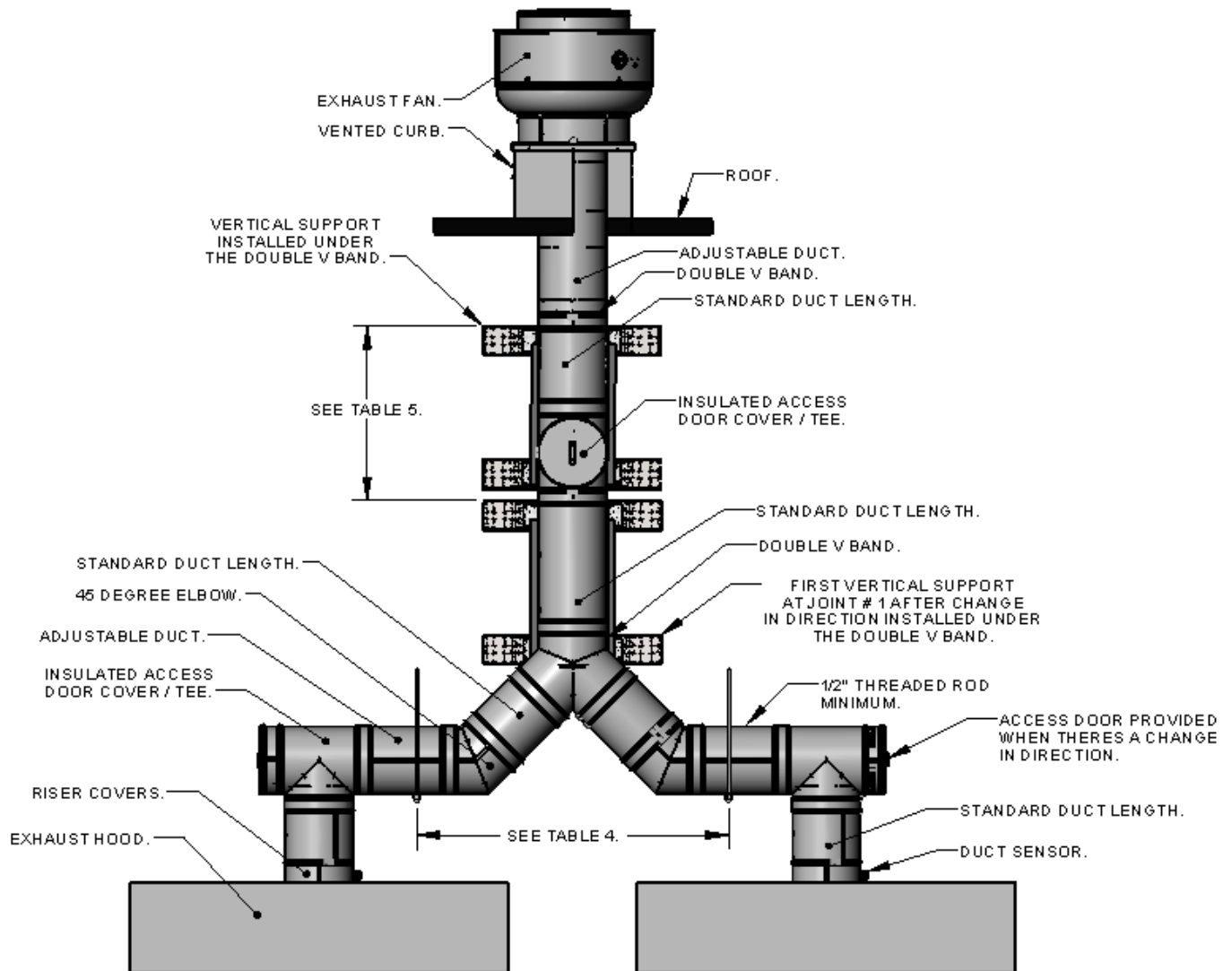

Fig. 15 - Grease Duct Installation Guide

Adjustable duct and standard ducts are used to terminate at the transition plate. The duct section is fully welded to the transition plate at the factory.

Grease Duct Installation:

The illustration shown provides useful information on the installation of grease duct systems. Each installation is specific to the application and the job site. If you encounter a situation not covered by this illustration, refer to the guide or consult the factory. The grease duct systems illustrated in this manual have been tested to and comply with UL 2221, Tests of Fire Resistive Grease Duct Enclosure Assemblies.

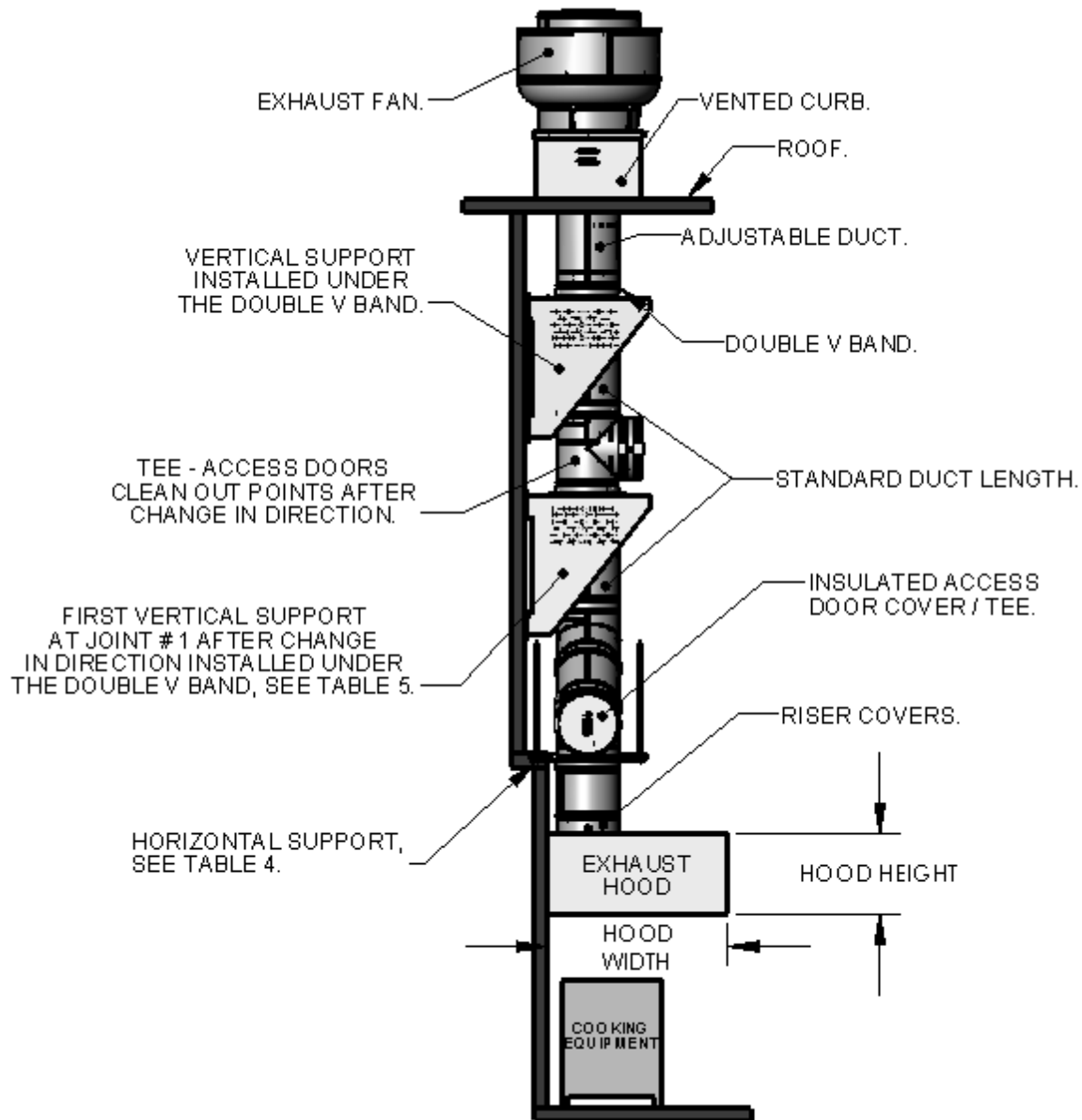
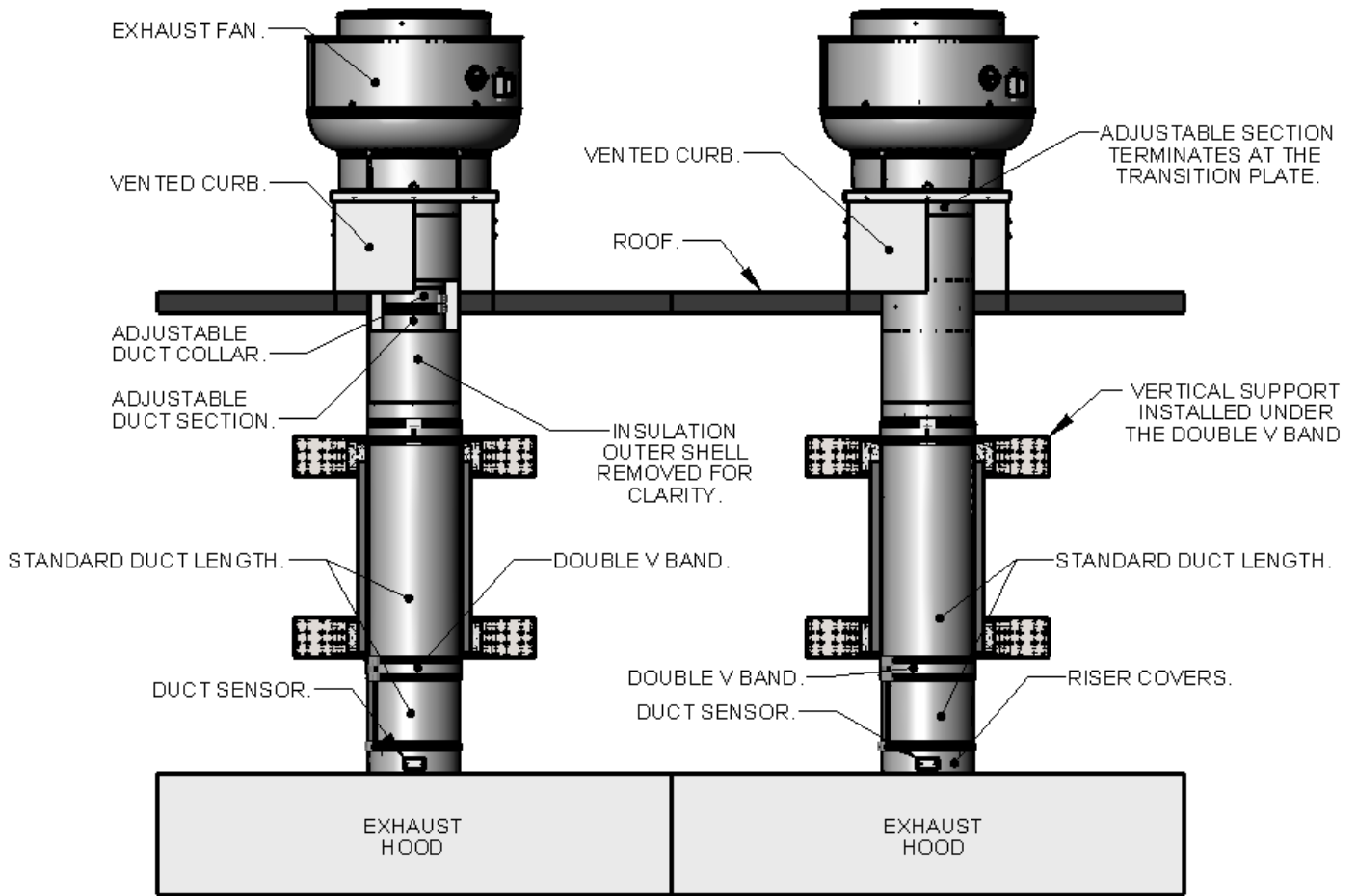

Fig. 16 - Grease Duct Installation Guide

Adjustable duct and standard ducts are used to terminate at the transition plate. The duct section is fully welded to the transition plate at the factory.

Grease Duct Installation:
 The illustration shown provides useful information on the installation of grease duct systems. Each installation is specific to the application and the job site. If you encounter a situation not covered by this illustration, refer to the guide or consult the factory. The grease duct systems illustrated in this manual have been tested to and comply with UL 2221, Tests of Fire Resistive Grease Duct Enclosure Assemblies.



METHODS USED TO TEST DUCT AFTER ASSEMBLY

Prior to the concealment of any portion of a grease duct system, a leakage test shall be performed in the presence of the code official. Duct shall be considered to be concealed when installed in shafts, or covered by coatings or wraps that prevent the ductwork from being visually inspected on all sides. A light test or approved equivalent test method (smoke test) shall be performed to determine that all joints are liquid tight. The smoke test is used for longer duct runs while the light test is used for short duct runs; both methods are approved for use.

Method 1 – Light Test per IMC 506.3.3.1

A light test shall be performed by passing a lamp having a power rating of not less than 100 watts through the entire section of ductwork to be tested. The lamp shall be open so as to emit light equally in all directions perpendicular to the duct walls. The test shall be performed for the entire duct system, including the hood-to-duct connection. The ductwork shall be permitted to be tested in sections, provided that every joint is tested.

Method 2 – Smoke Test

After the ductwork has been installed allow the listed sealant to cure for a minimum of 24 hours. Smoke bombs are lit and placed at the bottom of the duct system; natural upwards drafts will pull the smoke to the top of the duct system. Various length duct runs may require multiple smoke bombs. Once the smoke has reached the top of the duct run, cap the duct securely. Inspect all joints for leakage.

GENERAL DUCT WEIGHTS

The average weight of the duct, per foot of length, can be calculated using the following formulas below. Duct design should provide adequate support to ensure duct components are not overloaded.

Weight – DW-2R

The following formula can be used to approximate the weight of total length of DW-2R double wall duct. Inner Shell + Outer Shell + Insulation or $(.0327 * L * D) + [.0218 * L * (D+4)] + [.0364 * L * (D+2)]$.

Weight – DW-3R

The following formula can be used to approximate the weight of total lengths of DW-3R double wall duct. Inner Shell + Outer Shell + Insulation or $(.0327 * L * D) + [.0218 * L * (D+6)] + [.0436 * L * (D+3)]$.

Weight – DW-3Z

The following formula can be used to approximate the weight of total lengths of DW-3Z double wall duct. Inner Shell + Outer Shell + Insulation or $(.0327 * L * D) + [.0218 * L * (D+6)] + [.0491 * L * (D+3)]$.

Weight – Example

The “D” value in the formulas above represents the inner duct diameter in inches. The “L” value in the formulas above represents the total length in inches. Duct system: DW-3Z, 12” inner duct, 100 FT long. Using the DW-3Z formula above, $(.0327 * 1200 * 12) + (.0218 * 1200 * 18) + (.0491 * 1200 * 15) = 1825$ lbs.

