

# DOAS/RTU Curb Dimensions

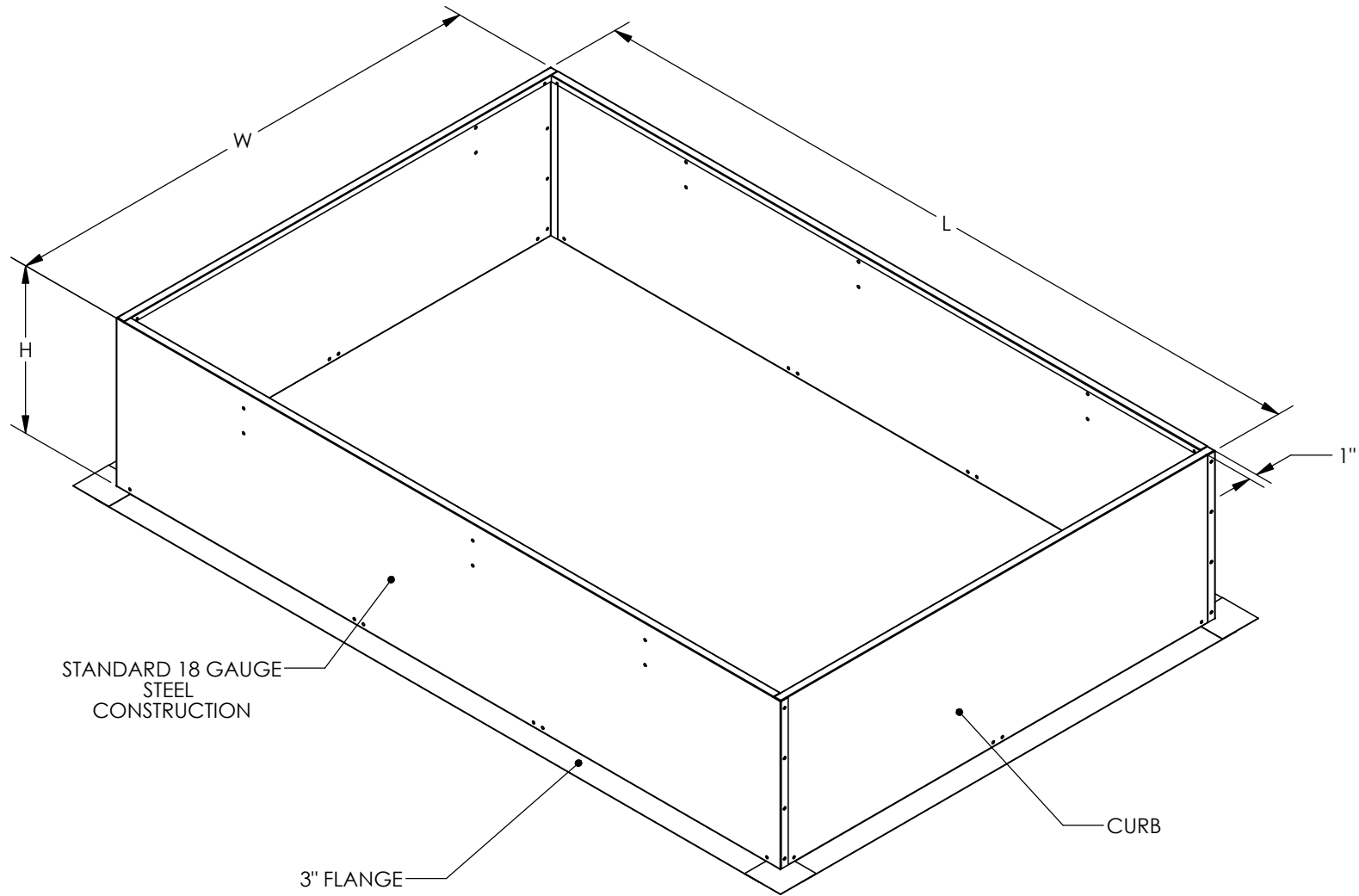

<b>DOAS/RTU Curb Dimensions</b>								
	<b>SIZE 1</b>	<b>SIZE 2</b>	<b>SIZE 3</b>	<b>SIZE 4</b>	<b>Size 1 Unicurb</b>	<b>Size 2 Unicurb</b>	<b>Size 3 Unicurb</b>	<b>Size 4 Unicurb</b>
<b>H</b>	VARIABLE	VARIABLE	VARIABLE	VARIABLE	VARIABLE	VARIABLE	VARIABLE	VARIABLE
<b>L</b>	71	75	91	111	111	120 1/4	142	169 1/2
<b>W</b>	41	49 1/2	59 1/2	80	41	49 1/2	59 1/2	80

# DOAS/RTU DUCT HANGER

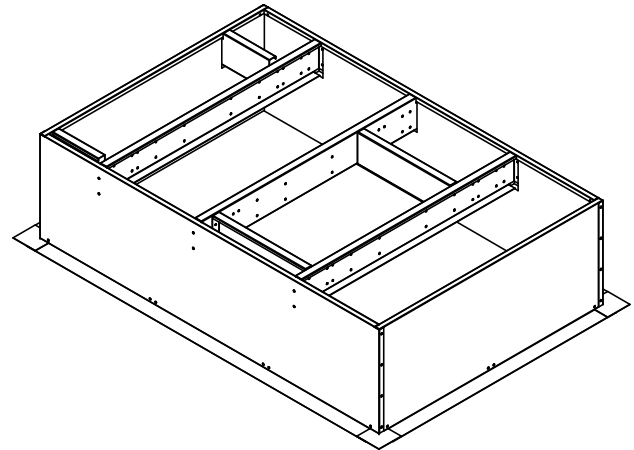
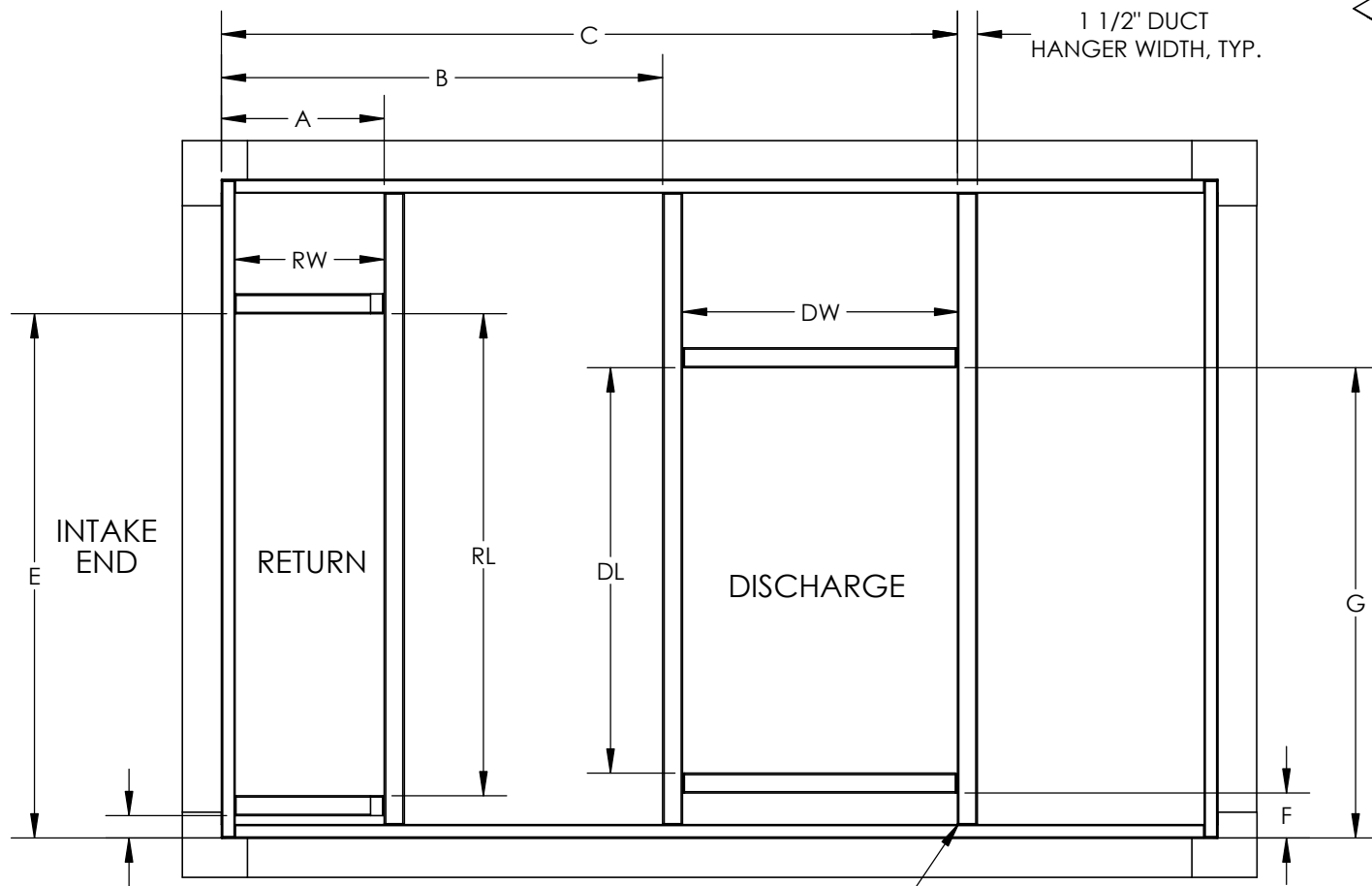

FASTEN DUCT HANGERS USING 1/4"-20x5/8" PAN HEAD PHILLIPS SCREWS (A0005680) AND NUTS (A0005690).

	DUCT DIMENSIONS (IN.)			
	SIZE 1	SIZE 2	SIZE 3	Size 4
<b>DW</b>	21 3/4	20 1/2	21 1/2	30 7/8
<b>DL</b>	22 1/4	30 1/4	39	39 3/4
<b>RW</b>	11 3/4	9	13 1/2	12 1/4
<b>RL</b>	30 1/4	36	45 1/2	74

	DOAS/RTU Curb Dimensions			
	SIZE 1	SIZE 2	SIZE 3	SIZE 4
<b>A</b>	12 3/4	12 1/4	16 5/8	15 1/2
<b>B</b>	36 1/8	33 3/16	48 1/16	60 1/8
<b>C</b>	59 1/4	55 3/8	71 9/16	93 13/16
<b>D</b>	N/A	1 11/16	N/A	N/A
<b>E</b>	31 1/4	39 7/16	48 3/8	N/A
<b>F</b>	3 13/16	3 3/8	2 5/8	29 3/8
<b>G</b>	27 9/16	35 3/8	43 1/2	70 3/4

# DOAS/ERV UNICURB DUCT HANGER

FASTEN DUCT HANGERS USING 1/4"-20x5/8" PAN HEAD PHILLIPS SCREWS (A0005680) AND NUTS (A0005690).

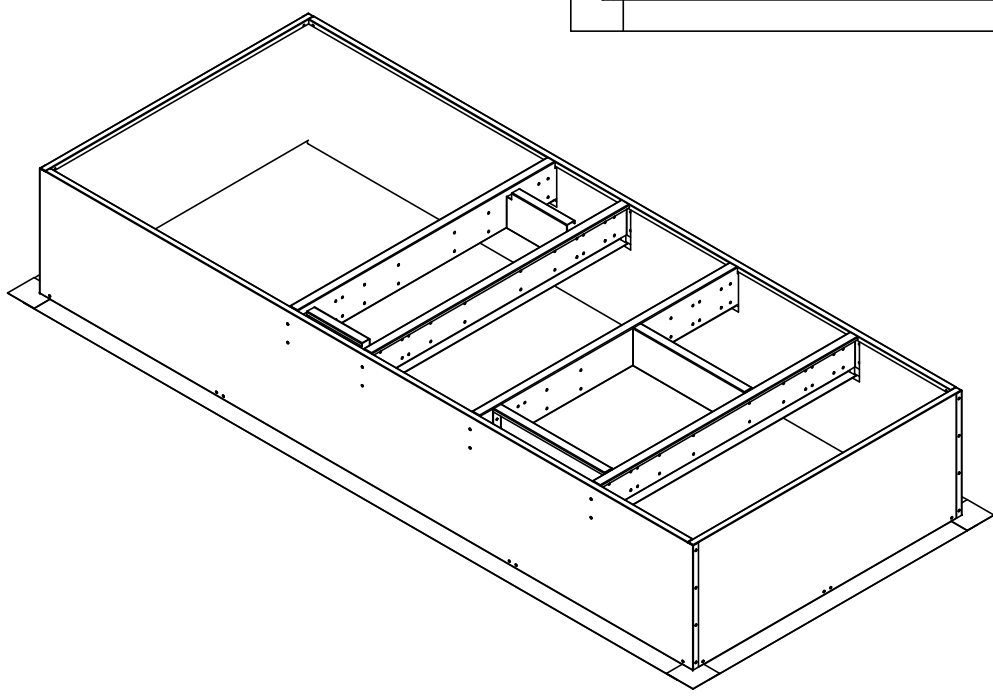
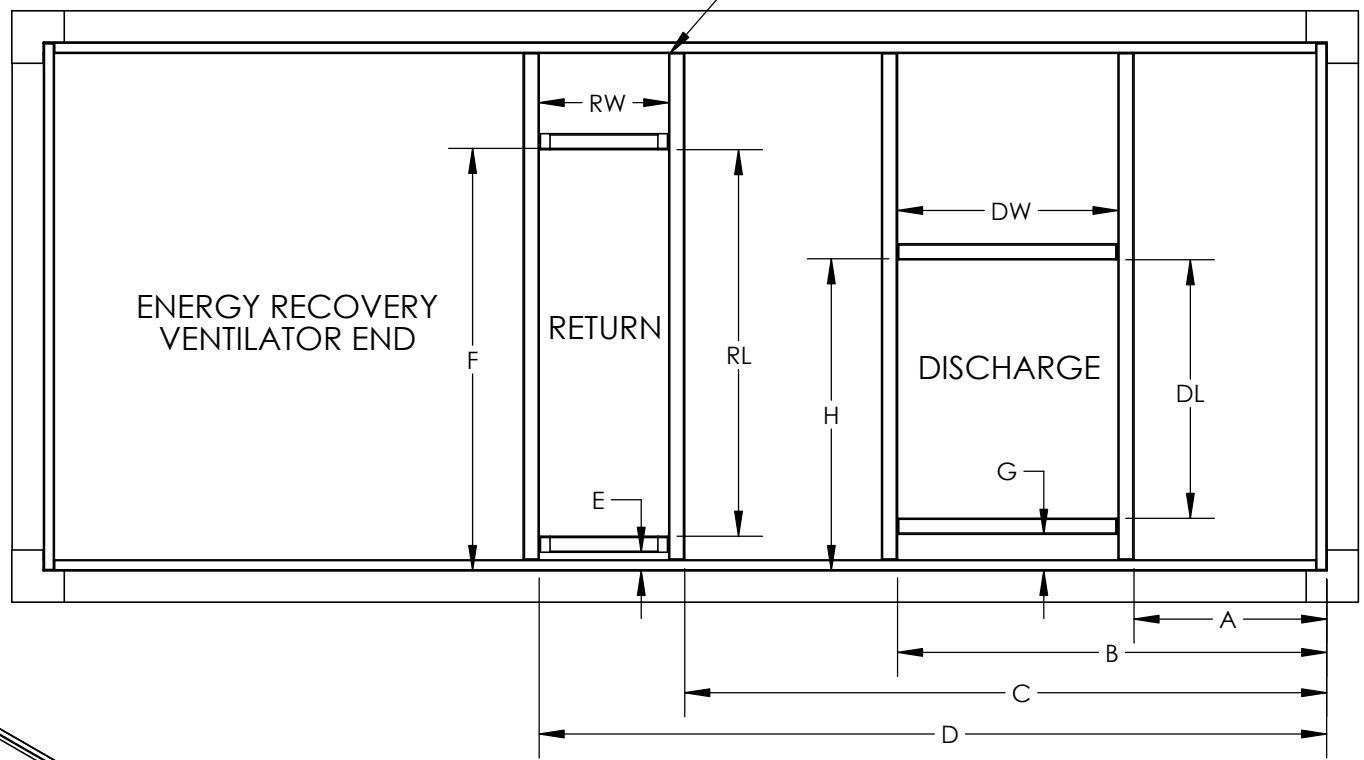

\*\* Size 2, 3, & 4 UniCurbs are built as a split curb due to their overall length

DUCT DIMENSIONS (IN.)				
	SIZE 1	SIZE 2	SIZE 3	Size 4
DW	21 3/4	20 1/2	21 1/2	30 7/8
DL	22 1/4	30 1/4	39	39 3/4
RW	11 3/4	9	13 1/2	12 1/4
RL	30 1/4	36	45 1/2	74

DOAS/ERV Unicurb Dimensions				
	SIZE 1	SIZE 2	SIZE 3	SIZE 4
A	10 3/16	18 1/16	17 13/16	15 9/16
B	33 5/16	40 1/4	41 5/16	49 5/16
C	56 3/16	60 3/16	72 1/16	93 13/16
D	70 3/8	73 13/16	90 1/8	109 15/16
E	N/A	1 11/16	N/A	N/A
F	31 1/4	39 7/16	48 3/8	N/A
G	3 13/16	3 3/8	2 5/8	29 3/8
H	27 9/16	35 3/8	43 1/2	70 13/16