

January, 2002

INSTALLATION INSTRUCTIONS DIMENSIONS AND SUBMITTAL DATA

power exhaust accessory for gravity vented gas-fired equipment

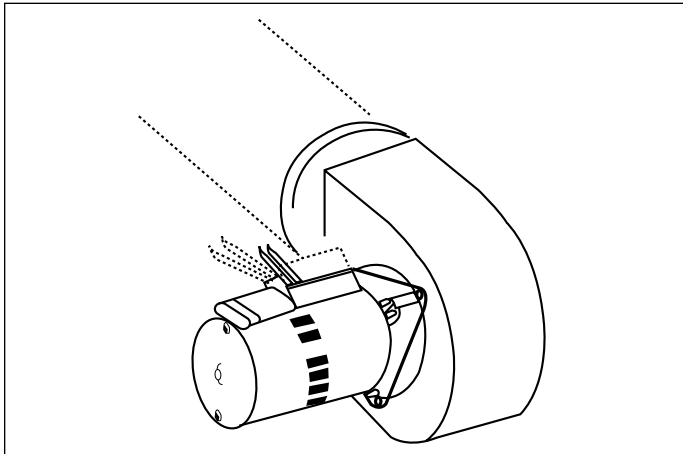

! WARNING

1. Improper installation, adjustment, alteration, service or maintenance can cause property damage, injury or death, and could cause exposure to substances which have been determined by various state agencies to cause cancer, birth defects, or other reproductive harm. Read the installation, operating, and maintenance instructions thoroughly before installing or servicing this equipment.
2. The installation and maintenance instructions in the unit manual as well as the following instructions must be followed to provide safe, efficient and trouble-free operation. In addition, particular care must be exercised regarding the special precautions listed on page 2 of the units Installation and Service Manual. Failure to properly address these critical areas could result in property damage or loss, personal injury, or death. These instructions are subject to any more restrictive local or national codes.

! CAUTION

This power exhauster (for horizontal or vertical venting) is designed for use on gas-fired unit heaters and duct furnaces made by Modine Manufacturing Company. The power exhauster adapter is to be used with the power exhauster. Do not use the adapter on any heater model other than that specified in this manual. A restrictive type vent cap (i.e. Breidert Type L, Gary Steel 1092) should be used when power exhausting.

IMPORTANT

The use of this manual is specifically intended for a qualified installation and service agency. All installation and service of these units must be performed by a qualified installation and service agency. Modine manuals may contain excerpts from component supplier literature adapted for Modine products. Any accompanying component supplier literature is for general information.

Packaging

The power exhauster is shipped in two packages. The power exhaust in one carton and the adapter kit for the unit heater or duct furnace in a separate carton.

Application – When to use this Power Exhaust

To overcome venting difficulties of gas-fired unit heaters and duct furnaces due to:

1. Non-linear or irregular vent runs.
2. Long horizontal vent runs.
3. Negative pressure areas.
4. Low ambient temperature areas restraining natural drafts.

Available Voltages

The PV-124 power exhaust is furnished with tri-voltage 115V/208V-230V single phase motors. Each motor displays a wiring diagram showing the wiring schematic for 115 V or 208V/230V power. When utilizing 460V 3 ϕ power, a 250VA transformer must be used to step down to 230V or 115V. The power exhaust includes a 25-volt factory mounted relay for operation with the gas unit's 25-volt control system.

Operation

The power exhaust contains an integrally mounted motor that is controlled by a room thermostat. When the thermostat senses the requirement for heat, it starts the exhaust motor. When the motor reaches proper running speed, a built-in centrifugal switch closes; thus the automatic gas valve, which is electrically in series with the switch, becomes energized and gas flows to the burner. When the thermostat is satisfied, the exhaust motor stops, centrifugal switch opens, and gas valve closes. If the motor does not run or reach proper running speed, the centrifugal switch will not close and the automatic gas valve will not be energized.

INSTALLATION

Power Exhauster Installation Instructions

To install the power exhaust, proceed as follows:

1. Verify that the correct adapter is to be installed on the unit. The carton is marked with the part number suffix for reference. For example, for a PD250 unit, the power exhauster box would be marked with suffix C11. This number can then be found in the following corresponding table. For a PD unit table 2.1 identifies a part number of 5H602696C11 where the suffix is C11. The adapter should also be checked against the adapter dimensions listed in table 3.1 by again using the part number of the adapter found in tables 2.1, 2.2, or 3.1.
2. For PD/BD/DJE/DHE/IJE/IHE, assemble adapter over outlet collar of flue. Drill two (2) 1/8" diameter holes into flue collar

through holes provided in adapter flange, and fasten with two (2) #10 sheet metal screws. The "S" type clip will hold the bottom mounting plate flange to bottom of flue collar. Sheet metal screws may also be used here if desired. (see figure 2.1) **For DFG/DBG/DCG/IFG/IBG/ICG**, assemble adapter over outlet collar of flue. Drill three (3) 1/8" diameter holes into flue collar through adapter in evenly spaced intervals around adapter. Fasten with three (3) #10 sheetmetal screws.

3. Assemble exhaust over collar of the adapter. Rotate exhaust to desired discharge position and fasten securely in place with sheet metal screws.
4. Refer to tables 2.1, 2.2, and 3.1 for vent pipe diameter. Typically a smaller diameter flue pipe will be used if all requirements can be met.

Figure 2.1 Typical Power Exhauster Installation

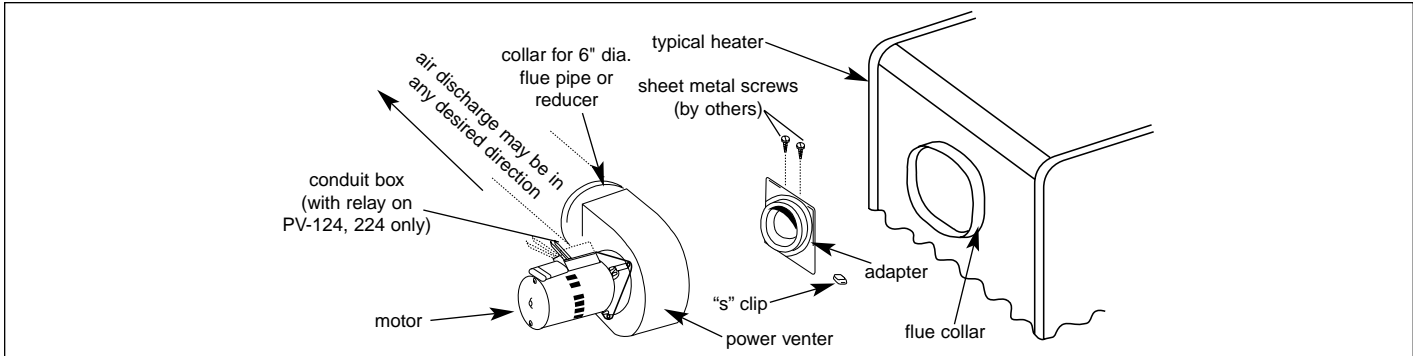

Table 2.1 PD/BD - Allowable Horizontal Vent Pipe Lengths for Modine Power Exhausts

Negative Pressure in a Building, Inches H ₂ O			.00	.05	.10	.15	.20	.25	.30	.35	.40	.45	.50	.55	.60
Model Size	Adapter Part No.	Vent Pipe \varnothing Diameter — Inches	Length of Pipe in Feet												
30	3H602696C1	4	*	*	*	*	*	*	23	—	—	—	—	—	—
		5	*	*	*	*	*	*	60	—	—	—	—	—	—
50	3H602696C12	4	*	*	*	*	*	*	*	*	25	—	—	—	—
		5	*	*	*	*	*	*	*	*	65	—	—	—	—
75	3H602696C2	4	*	*	*	*	*	85	53	21	—	—	—	—	—
		5	*	*	*	*	*	*	*	56	—	—	—	—	—
100	3H602696C3	4	85	68	52	36	19	—	—	—	—	—	—	—	—
125	3H602696C14	4	*	*	92	78	63	49	34	20	5	—	—	—	—
		5	*	*	*	*	*	*	90	52	14	—	—	—	—
150	3H602696C4	4	76	69	62	55	48	41	34	27	19	12	—	—	—
		5	*	*	*	*	*	*	89	70	51	32	—	—	—
175	3H602696C4	4	77	69	61	52	44	36	28	20	11	3	—	—	—
		5	*	*	*	*	*	*	95	73	52	30	9	—	—
200	3H602696C15	4	61	55	48	44	38	32	26	17	14	11	8	0	—
		5	182	155	148	130	113	96	79	68	43	34	25	15	6
250	3H602696C11	4	47	43	39	35	32	28	24	20	17	13	—	—	—
		5	*	*	*	93	83	73	63	53	43	33	—	—	—
300	3H602696C6	6	*	*	96	79	63	47	31	15	—	—	—	—	—
350	3H602696C7	6	*	93	83	72	62	52	42	32	—	—	—	—	—
400	3H602696C7	6	*	66	57	47	38	29	19	10	0	—	—	—	—

Table 2.2 DJE/DHE/IJE/IHE - Allowable Horizontal Vent Pipe Lengths for Modine Power Exhausts

Negative Pressure in a Building, Inches H ₂ O			.00	.05	.10	.15	.20	.25	.30	.35	.40	.45	.50	.55	.60
Model Size	Adapter Part No.	Vent Pipe \varnothing Diameter — Inches	Length of Pipe in Feet												
75	3H602696C2	4	*	*	*	*	*	95	63	32	—	—	—	—	—
		5	*	*	*	*	*	*	*	95	—	—	—	—	—
100	3H602696C3	5	*	*	*	93	50	—	—	—	—	—	—	—	—
125	3H602696C4	4	*	*	96	86	77	64	58	49	40	31	21	—	—
		5	*	*	*	*	*	*	*	*	*	91	62	34	—
150	3H602696C5	4	44	39	33	28	23	17	12	0	—	—	—	—	—
200		5	*	98	90	82	74	65	57	49	41	33	25	16	8
250	3H602696C6	6	*	*	98	86	74	63	52	40	28	16	—	—	—
300	3H602696C7	6	*	*	*	*	*	87	74	60	47	35	—	—	—
350		6	*	98	88	78	68	58	48	38	28	18	—	—	—
400	3H602696C7	6	*	98	88	78	68	58	48	38	28	18	—	—	—

* In excess of 100'. **NOTE:** Subtract 7 equivalent feet for each elbow. Subtract 8 equivalent feet for vent cap.

① Where 4 and 5 appear it is the customer's choice. Typically the smaller flue pipe diameter that meets all the requirements is used.

INSTALLATION

Table 3.1
DFG/DBG/DCG/IFG/IBG/ICG - Allowable Horizontal Vent Pipe Lengths for Modine Power Exhausts

Pressure in Unit Location ("W.C.)			0.00	0.05	0.10	0.15	0.20	0.25	0.30	0.35	0.40	0.45	0.50	0.55	0.60	.70
Model size	Adapter Part No.	Vent Pipe Diameter (in) ①	Allowable Length of Vent Pipe (ft)													
75	3H36369B1	4	*	*	*	*	*	87	68	49	30	11	-	-	-	-
		5	*	*	*	*	*	*	*	*	94	35	-	-	-	-
100	3H36369B2	4	*	*	*	*	*	*	*	*	*	96	72	48	24	-
		5	*	*	*	*	*	*	*	*	*	*	*	*	75	-
125	3H36369B3	4	*	*	98	87	76	65	54	43	33	22	11	-	-	-
		5	*	*	*	*	*	*	*	*	*	*	68	34	-	-
150	3H36369B4	4	29	27	25	23	21	19	17	15	13	11	9	7	5	2
		5	92	86	80	74	67	61	55	49	42	36	30	24	17	5
175	3H36369B4	4	26	24	23	21	19	17	16	14	12	10	9	7	5	2
		5	83	78	72	67	61	56	50	44	39	33	28	22	17	6
200	3H36369B4	4	44	41	39	36	33	30	27	24	21	18	16	13	10	4
		5	*	*	*	*	*	95	86	77	68	59	49	40	31	13
225	3H36369B4	4	40	37	35	32	29	27	24	22	19	17	14	12	9	4
		5	*	*	*	*	94	86	78	69	61	53	45	37	29	13
250	3H36369B5	5	77	71	66	61	55	50	45	39	34	29	23	18	13	2
		6	*	*	*	*	*	*	*	*	*	88	74	60	47	33
300	3H36369B6	5	*	95	88	82	75	68	62	55	48	41	35	28	21	8
		6	*	*	*	*	*	*	*	*	*	*	89	72	55	21
350	3H36369B6	5	53	49	45	41	37	33	29	25	21	17	13	9	5	-
		6	*	*	*	*	96	85	75	64	54	44	33	23	12	-
400	3H36369B6	5	60	55	51	46	42	37	32	28	23	18	14	9	5	-
		6	*	*	*	*	*	95	83	71	59	48	36	24	12	-

* In excess of 100'. **NOTE:** Subtract 7 equivalent feet for each elbow. Subtract 8 equivalent feet for vent cap.
① Where 4 and 5 appear it is the customer's choice. Typically the smaller flue pipe diameter that meets all the requirements is used.

Table 3.2
Dimensional Data – Flue Adapter

Adapter No.	Adapter Dimensions		
	A	B	C
3H602696C1	4.88	3.0	1.25
3H602696C2	6.12	3.62	1.62
3H602696C3	7.12	4.62	2.25
3H602696C4	8.12	5.62	2.88
3H602696C5	9.0	6.75	4.0
3H602696C6	10.0	7.7	4.12
3H602696C7	11.25	7.7	4.12
3H602696C11	9.0	6.75	4.12
3H602696C12	4.88	3.0	1.62
3H602696C13	6.12	3.62	2.25
3H602696C14	7.12	4.62	2.88
3H602696C15	8.12	5.62	4.0
3H36369B1	5.0	2.0	N/A
3H36369B2	6.0	2.0	N/A
3H36369B3	6.0	2.38	N/A
3H36369B4	7.0	4.0	N/A
3H36369B5	8.0	4.0	N/A
3H36369B6	10.0	4.0	N/A

Figure 3.1
Flue Adapters
3H602696 C1-C4 and C12-C15

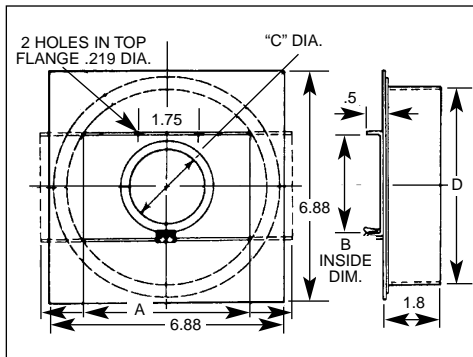

Figure 3.2
Flue Adapters
3H602696 C5-C7 and C11

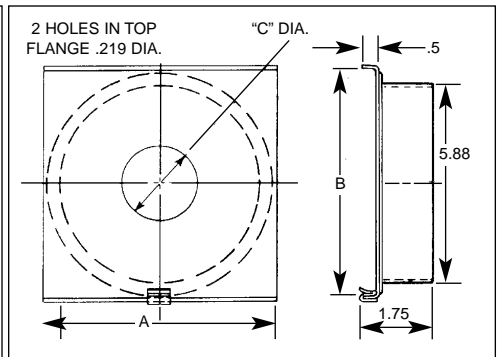

Figure 3.3
Flue Adapters
3H36369 B1-B3

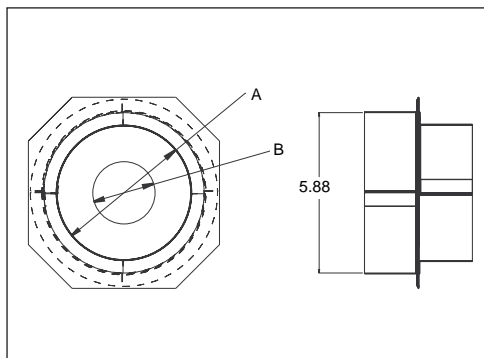
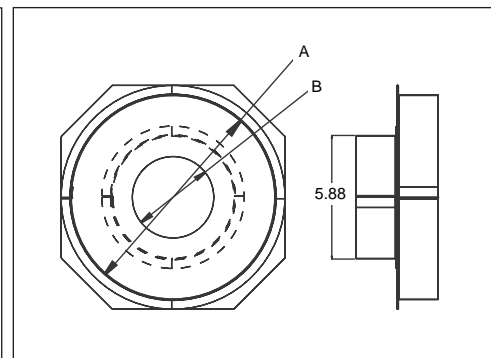
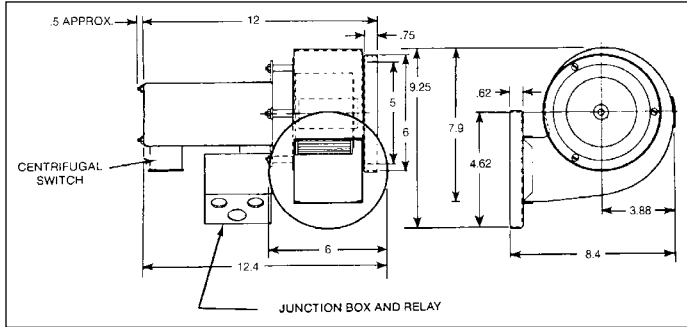

Figure 3.4
Flue Adapters
3H36369 B4-B6



INSTALLATION

Dimensional Data – Model PV-124 with 24-Volt Relay Control



Venting

⚠ WARNING

1. Gas fired heating equipment must be vented - do not operate unvented.
2. A built-in draft diverter is provided - additional external power exhausters are not required or permitted.
3. Gas-fired heating equipment which has been improperly vented, or which experiences a blocked vent condition may have flue gasses accidentally spilled into the heated space. See unit installation and service manual for specific information about the blocked vent safety switch supplied on the unit.
4. If you are replacing an existing heater, it may be necessary to resize the venting systems. Improperly sized venting systems can result in vent gas leakage of the formulation of condensate. Refer to the National Fuel Gas Code ANSI Z223.2 or CAN/CGA B149.1 or .2 latest edition. Failure to follow these instructions can result in serious injury or death.

⚠ CAUTION

Installation must conform with local building codes or in the absence of local codes, with Part 7, Venting of Equipment, of the National Fuel Gas Code, ANSI Z223.1 (NFPA 54) - Latest Edition. In Canada, installation must be in accordance with CAN/CGA-B149.1 for natural gas units and CAN/CGA-B149.2 for propane units.

General Venting Air Instructions

1. Installation of venting must conform with local building codes, or in the absence of local codes, with the National Fuel Gas Code, ANSI Z223.1 (NFPA 54) - Latest Edition. In Canada, installation must be in accordance with CAN/CGA-B149.1 for natural gas units and CAN/CGA-B149.2 for propane units.
2. All vertically vented units with single-stage controls are Category I. All vertically vented units with two-stage or modulating controls are Category II. The installation of a Category II unit must conform to the requirements from Table 4.1 in addition to those listed below.
3. From Tables 2.1, 2.2 or 3.1, select the size of vent pipe that fits the flue outlet. Do not use a vent pipe smaller than the size listed. The pipe should be galvanized steel or other suitable corrosion resistant material. Follow the National Fuel Gas Code for minimum thickness of vent material. The minimum thickness for connectors varies depending on the pipe diameter.
4. Vent pipes should be fitted with a tee with a drip leg and a clean out cap to prevent against the possibility of any moisture in the vent pipe from entering the unit. The drip leg should be inspected and cleaned out periodically during the heating season.

5. The National Fuel Gas Code requires at least 6 inches from combustible materials for single wall vent pipe. The minimum distance from combustible materials is based on the combustible material surface not exceeding 160°F. Clearance from the vent pipe (or the top of the unit) may be required to be greater than 6 inches if heat damage other than fire (such as material distortion or discoloration) could result.
6. Avoid venting through unheated space. When venting does pass through an unheated space, insulate runs greater than 5 feet to minimize condensation. Inspect for leakage prior to insulating and use insulation that is noncombustible with a rating of not less than 350°F. Install a tee fitting at the low point of the vent system and provide a drip leg with a clean out cap as shown in Figure 5.1.
7. When the vent passes through an interior wall or floor, a metal thimble 4 inches greater than the vent diameter is necessary. If there is 6 feet or more of vent pipe in the open space between the appliance and where the vent pipe passes through the wall or floor, the thimble need only be 2 inches greater than the diameter of the vent pipe. If a thimble is not used, all combustible material must be cut away to provide 6 inches of clearance. Any material used to close the opening must be noncombustible.

Table 4.1
ANSI Venting Requirements

Appliance Category	Description	Venting Requirements
I	Negative vent pressure Non-condensing	Follow standard venting requirements.
II	Negative vent pressure Condensing	Condensate must be drained.
III	Positive vent pressure Non-condensing	Vent must be gastight.
IV	Positive vent pressure Condensing	Vent must be liquid and gastight. Condensate must be drained.

8. Do NOT use dampers or other devices in the vent or combustion air pipes.
9. Precautions must be taken to prevent degradation of building materials by flue products.
10. The outlet of the vent should extend as shown in Figure 5.1 and Table 4.2 for vents 12" in diameter or smaller that do not terminate within 10' of a vertical wall or similar obstruction. For vents larger than 12" or vents that terminate within 10' of a vertical wall or similar obstruction the terminal outlet must be a minimum of 2' higher than the vertical wall or similar obstruction within a distance of 10' (refer to Figure 5.2)
11. Use a vent terminal to reduce downdrafts and moisture in vent. A vent terminal that is very open will avoid spillage at unit's diverter relief opening and tripping of the blocked vent safety switch.

Table 4.2
**Minimum Height from Roof to
Lowest Discharge Opening**

Rise X (in)	Roof Pitch	Min Height H (ft)*
0-6	Flat to 6/12	1.00
6-7	6/12 to 7/12	1.25
7-8	7/12 to 8/12	1.50
8-9	8/12 to 9/12	2.00
9-10	9/12 to 10/12	2.50
10-11	10/12 to 11/12	3.25
11-12	11/12 to 12/12	4.00
12-14	12/12 to 14/12	5.00
14-16	14/12 to 16/12	6.00
16-18	16/12 to 18/12	7.00
18-20	18/12 to 20/12	7.50
20-21	20/12 to 21/12	8.00

* Size according to expected snow depth.

INSTALLATION

Figure 5.1

Vertical Venting (pitched roof)①

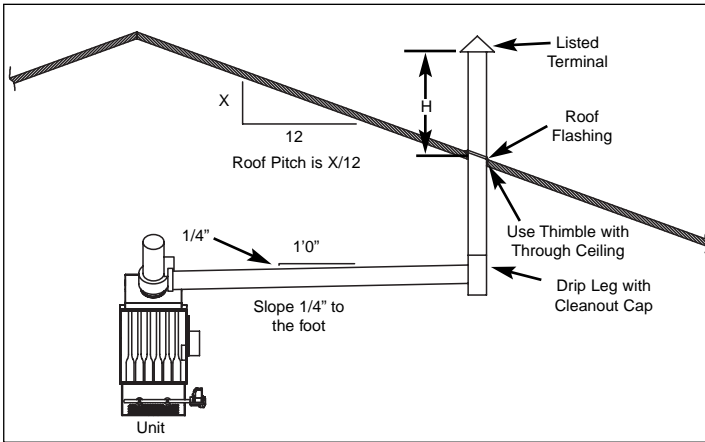
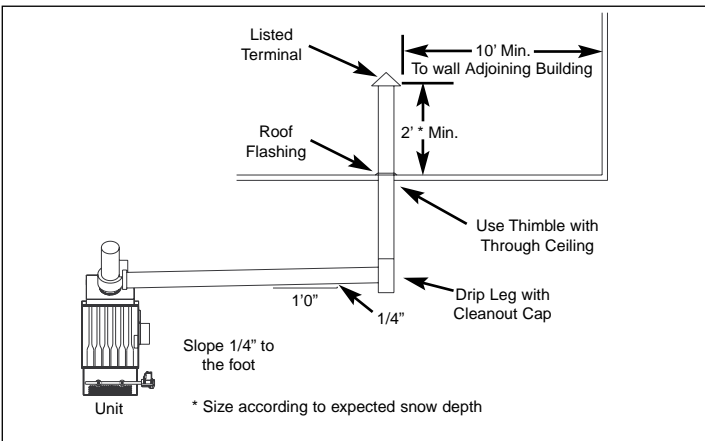

Figure 5.2

Vertical Venting (obstructed)①



General Instructions For Double Wall (Type B) Vent Pipe Installation:

A single section of double wall vent pipe used with a positive pressure vent system (cat III or IV as listed in table 4.1) must follow installation requirements for single wall vent pipe. Under no circumstances should two or more sections of double wall vent pipe be joined together within one positive pressure vent system due to the inability to verify a complete seal of the inner pipes. Multiple sections of double wall vent pipe may be used with a negative pressure vent system (cat I or II as listed in table 4.1).

1. How to attach a single wall vent cap to double wall (type B) vent pipe:
 - A. Look for the "flow" arrow on the vent pipe. Attach the vent cap to the exhaust end of the double wall vent pipe.
 - B. Slide the vent cap inside the pipe.
 - C. Drill a hole through the pipe and the vent cap. Using 3/4" long sheet metal screws, attach the cap to the pipe.
2. How to connect a single wall vent system to a double wall (type B) vent pipe:
 - A. Slide the single wall pipe inside the inner wall of the double wall pipe.
 - B. Drill a hole through both walls of the double wall pipe and through the single wall pipe. Using 3/4" sheet metal screws, attach the two pieces of pipe. Do not over tighten.
 - C. Repeat Step B drilling and inserting (2) additional screws, evenly spaced around the pipe.
 - D. To seal the annular opening, run a large bead of 350°F silastic. The "GAP" between the single and double wall pipe must be sealed but it is not necessary to fill the full volume of the annular area.

Additional Requirements for Horizontally Vented Category III Units

1. Seal all vent joints with a metallic tape or silastic suitable for temperatures up to 350°F. (3M tapes 425, 433 or 363 are acceptable.) Wrap tape two full turns around the vent pipe.
2. Limit the total equivalent vent pipe length to that listed in table 2.1, 2.2, or 3.1 as it pertains to your model and job conditions, making the vent system as straight as possible. (The equivalent length of a 3 inch elbow is 1 foot; a 4 inch elbow, 5 feet; a 5 inch elbow, 6 feet; a 6 inch elbow, 7 feet; and a 7 inch elbow, 11 feet.)
3. The vent terminal must be a Gary Steel 1092, Breidert Type L.
4. The vent must extend 6 inches beyond the exterior surface of an exterior wall as shown in Figure 3b. Precautions must be taken to prevent degradation of building materials by flue products.

Figure 5.3

Vent Construction Through Combustible Walls

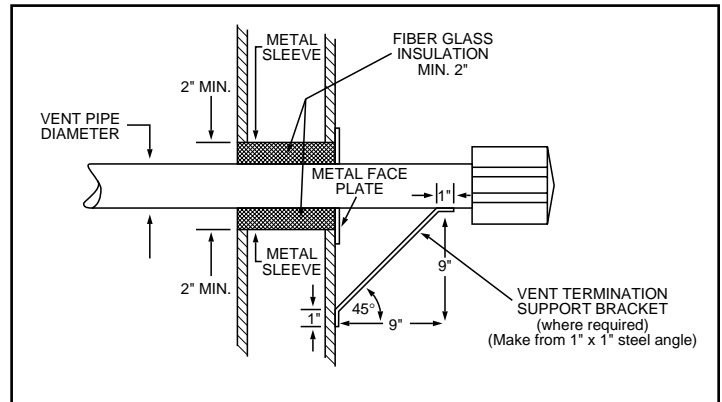
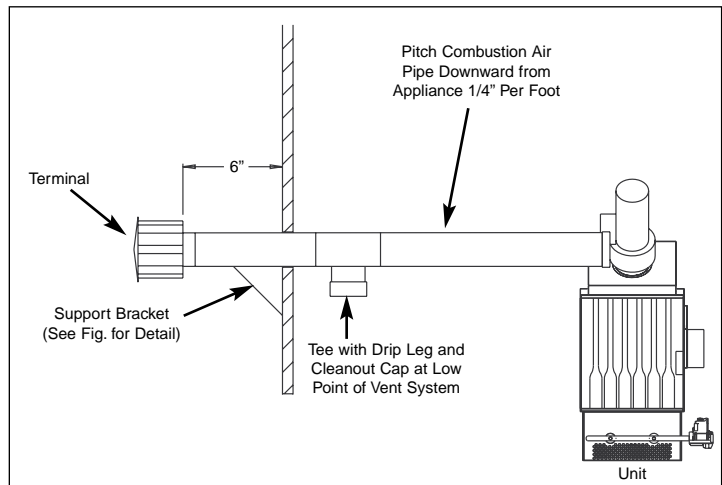

Figure 5.4

Horizontal Venting - Breidert or Gary Steel Vent Terminal ①



① Duct furnace unit shown for demonstration purposes only. Venting configuration also applies to system units and unit heaters listed in the manual.

Specifications — PV-124

Blower - Wheel type, forward curved, statically balanced.

Motor

Motor type — permanent split capacitor with T.O.L.

HP — 1/9

Voltage — 115/208-230/60/1

Amps — 1.6/.8 (Fasco) - 1.7/.87 (Universal)

RPM — 3000

Sealed ball bearings

1. Built-in automatic reset, thermal overload protection.
2. Ball bearings permanently lubricated for long life.
3. Centrifugal safety switch having normally open contacts which, when connected in series with the heater controls, prevents burner gas flow when the power exhaust fan is not operating.

Control System

A built-in centrifugal motor switch prevents gas flow to burner before sufficient draft is established. The PV-124 includes a 24-volt, factory-mounted, relay for operation on gas-fired units utilizing 25V low voltage control systems.

Fan Housing Assembly

The housing and discharge flange are fabricated of steel having baked-on electrostatically applied polyester resin powder paint finish.

Adapter

Required to connect the power exhaust to the heater flue outlet. Built-in restrictors are used to obtain optimum combustion and efficiency for all size heaters.

Maintenance

The exhaust motor does not require periodic lubrication. The bearings are permanently lubricated with a special high temperature lubricant. A periodic cleaning of blower wheel blades, motor, and centrifugal switch is recommended.

Electrical Connections



WARNING

1. Disconnect power supply before making wiring connections to prevent electrical shock and equipment damage.
2. All appliances must be wired strictly in accordance with wiring diagram furnished with the appliance. Any wiring different from the wiring diagram could result in a hazard to persons and property.
3. Any original factory wiring that requires replacement must be replaced with wiring material having a temperature rating of at least 105°C.

Installation of wiring must conform with local building codes, or in the absence of local codes, with the National Electric Code ANSI/NFPA 70 - Latest Edition. Unit must be electrically grounded in conformance to this code. In Canada, wiring must comply with CSA C22.1, Part 1, Electrical Code.

Typical Power Exhaust Wiring — PD/BD

1. Remove the factory installed buss bar (jumper) from between terminals "C" and "V" of terminal board.
2. Connect one red lead from centrifugal switch (CS) of power exhaust to terminal "C" on terminal board. Connect the other red lead from centrifugal switch (CS) to terminal "V" of terminal board.
3. Connect terminal (3) of power exhaust relay to terminal "T2" of terminal board.
4. Connect terminal (1) of power exhaust relay to terminal "G" of terminal board.

6

5. Connect terminal (2) of power exhaust relay to L1 of power supply in unit junction box.
6. Connect L2 lead from power exhaust motor to L2 lead of power supply in unit junction box.
7. Connect thermostat between terminals "T1" and "T2" of terminal board.

Check-Out Procedure

With the power and gas supply turned off, set the thermostat to its lowest setting.

1. If the unit has a standing pilot, turn on the gas supply only and light the pilot according to the instructions on the unit's serial plate, then proceed with Step 2. If the unit is equipped with an intermittent pilot ignition system, turn on the gas supply to unit and proceed with Step 2.
2. Turn on power supply to unit. Nothing should happen.
3. Turn up the thermostat to call for heat. The power exhaust motor should start, the centrifugal switch of the power exhaust should close, and the main burner should light. After a delay of approximately 30 seconds, the fan motor should start.
4. Turn the thermostat down again. The main burner and power exhaust motor should shut off. The fan motor should continue to run for approximately 1 to 1 1/2 minutes. Modine units are equipped with a time delay relay, and the fan motor is delayed for approximately 30 seconds on start-up, and 1 to 1 1/2 minutes on shut-down.
5. Check the power exhaust centrifugal switch for proper function. To do this, remove the centrifugal switch lead from terminal "V" of the terminal board. Turn up the thermostat to call for heat. The power exhaust motor should run, but the main burner should not light. After a 30 second delay, the fan motor should operate. The main burner should still not light.
6. Turn down the thermostat and allow the power exhaust motor and fan motor to stop running. Reconnect the centrifugal switch lead to terminal "V" of the terminal board. Recycle the unit as described in Steps 3 and 4.

If the unit does not operate in the sequence described above, recheck all wiring until the necessary correction to the wiring is found and corrected. Set the thermostat to the desired set point. The unit is now ready for use.

Figure 6.1
Typical Wiring — Power Exhaust Accessory
(Modine #79858 or #79861)

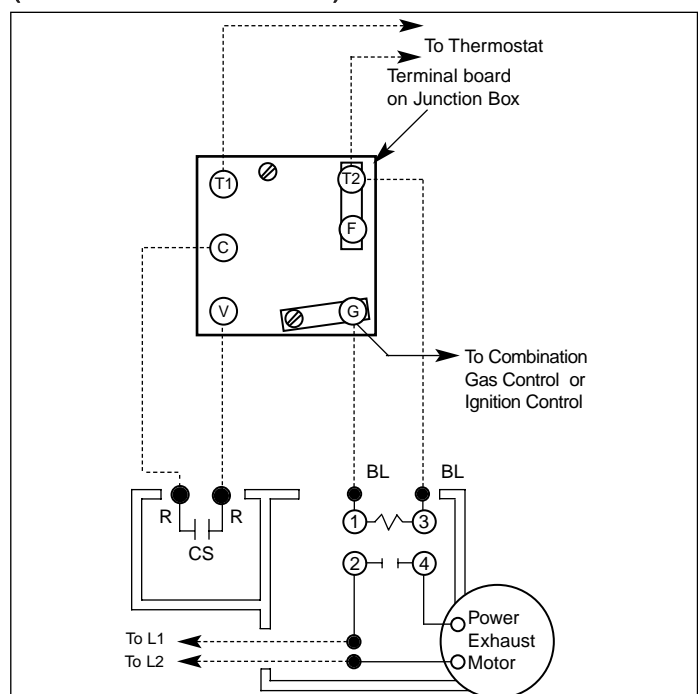

TYPICAL POWER EXHAUST WIRING - DJE/DHE/IJE/IHE

Figure 7.1

Typical Power Exhaust Wiring Models DJE/DHE/IJE/IHE

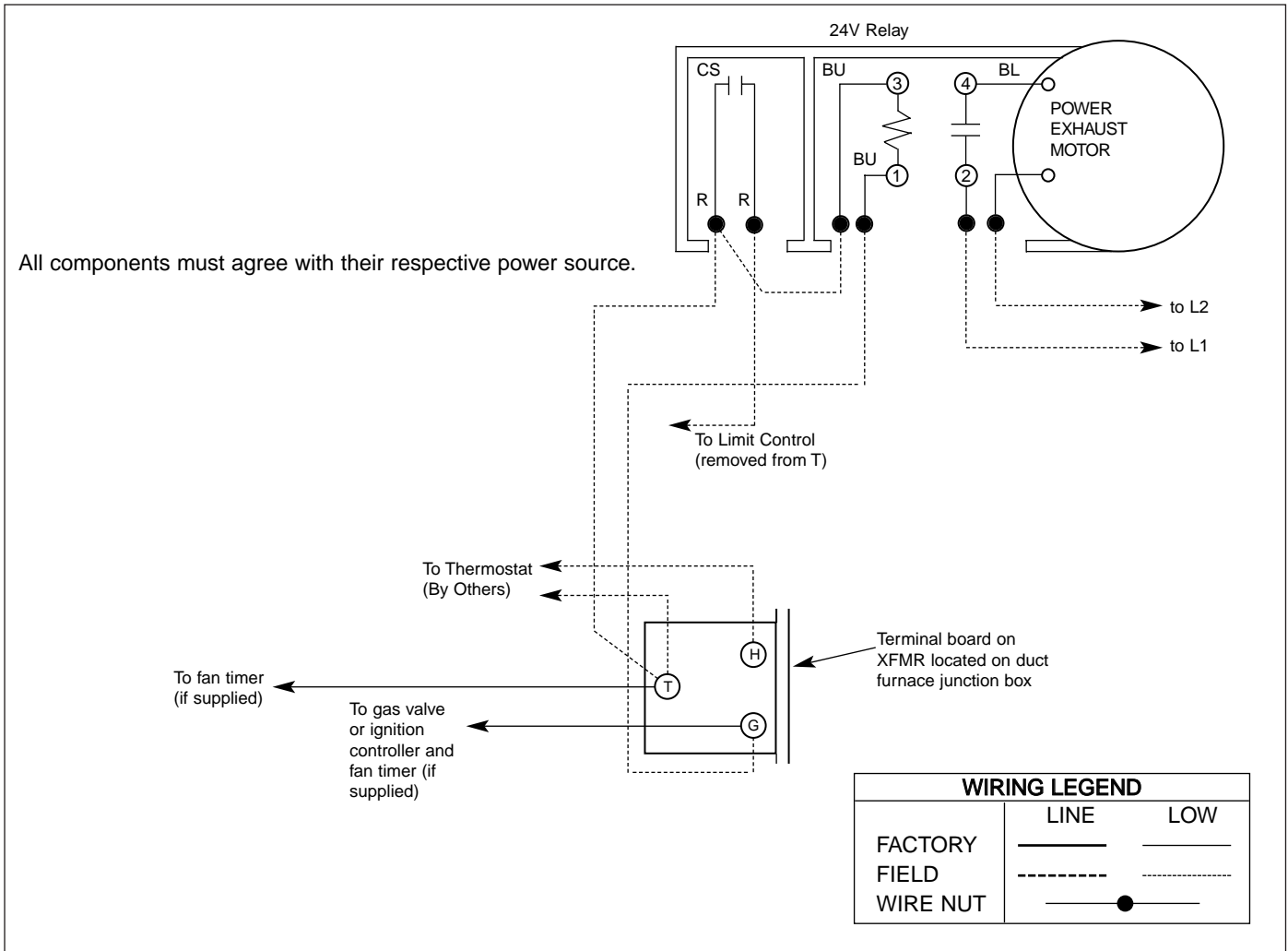

IMPORTANT: After installing the power exhaust and adapter kit, as per instructions on front cover, and wiring the power venter per Figure 7.1 for DJE, IJE, IHE and DHE models, use the following check-out procedure to check final installation.

Check-Out Procedure

With the power and gas supply turned off, set the thermostat to its lowest setting.

1. If the unit has a standing pilot, turn on the gas supply only and light the pilot according to the instructions on the unit's serial plate, then proceed with Step 2. If the unit is equipped with an intermittent pilot ignition system, turn on the gas supply to unit and proceed with Step 2.
2. Turn on power supply to unit. Nothing should happen.
3. Turn up the thermostat to call for heat. The power exhaust motor should start, the centrifugal switch of the power exhaust should close, and the main burner should light.
4. Turn the thermostat down again. The main burner and power exhaust motor should shut off.

5. Check the power exhaust centrifugal switch for proper function. To do this, remove the centrifugal switch lead on limit control. Turn up the thermostat to call for heat. The power exhaust motor should run, but the main burner should not light.
6. Turn down the thermostat and allow the power exhaust motor to stop running. Reconnect the centrifugal switch lead to limit control. Recycle the unit as described in Steps 3 and 4.

If the unit does not operate in the sequence described above, recheck all wiring until the necessary correction to the wiring is found and corrected. Set the thermostat to the desired set point. The unit is now ready for use.

TYPICAL POWER EXHAUST WIRING - DFG, IFG, DBG, IBG, DCG, ICG

Figure 8.1

Typical Power Exhaust Wiring Models DFG, IFG, DBG, IBG, DCG, ICG with digit 13=4

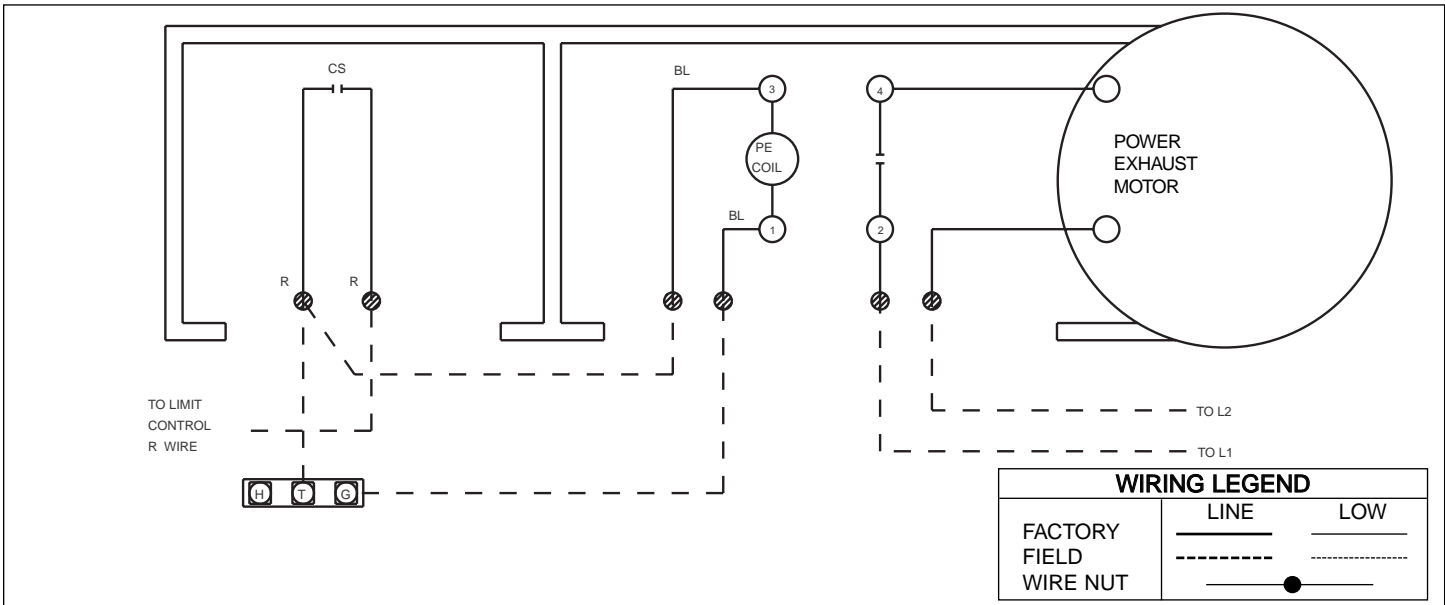
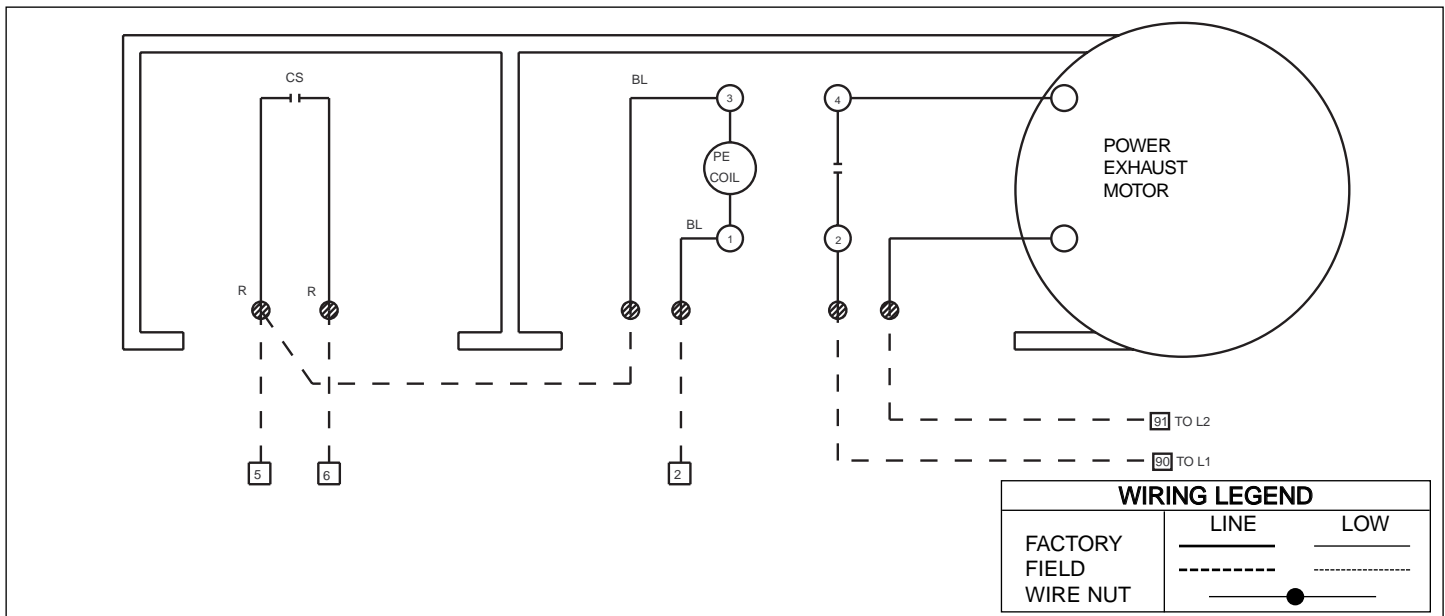

Figure 8.2

Typical Power Exhaust Wiring Models DFG, IFG, DBG, IBG, DCG, ICG with digit 13=0, 1, 2, or 3



IMPORTANT: After installing the power exhaust and adapter kit, as per instructions on front cover, and wiring the power venter per Figure 8.1 or 8.2 for DFG/IFG duct furnace and system units, use the following check-out procedure to check final installation.

Check-Out Procedure

1. If the unit has a standing pilot, turn on the gas supply only and light the pilot according to the instructions on the unit's serial plate, then proceed with Step 2. If the unit is equipped with an intermittent pilot ignition system, turn on the gas supply to unit and proceed with Step 2.
2. Turn on power supply to unit. Nothing should happen.
3. Turn up the thermostat to call for heat. The power exhaust motor should start, the centrifugal switch of the power exhaust should close, and the main burner should light. After a delay of approximately 30 seconds, the fan motor should start.
4. Turn the thermostat down again. The main burner and power exhaust motor should shut off.
5. Check the power exhaust centrifugal switch for proper function. To do this, remove the centrifugal switch lead on limit control (R) or terminal "6". Turn up the thermostat to call for heat. The power exhaust motor should run, but the main burner should not light. After a 30 second delay, the fan motor should operate. The main burner should still not light.
6. Turn down the thermostat and allow the power exhaust motor and fan motor to stop running. Reconnect the centrifugal switch lead to limit control (R) or terminal "6". Recycle the unit as described in Steps 3 and 4.

Commercial HVAC&R Division • Modine Manufacturing Company • 1500 DeKoven Avenue • Racine, Wisconsin 53403-2552
Phone: 1-800-828-4328 (HEAT) • Fax: 414-636-1665 • www.modine.com